

Freewheels

Backstops • Overrunning Clutches • Indexing Freewheels



Edition 2015/2016



Table of Contents

Freewheel Technology Introduction							Page
Design and Function of Freewheels							4
Applications of Freewheels							5
Areas of Application for Freewheels							6
Categories of Freewheels							8
Freewheels with Sprags or Rollers							10
Types for Extended Service Life							12
Determination of Selection Torque							14
Freewheel Selection							15
Complete Freewheels	Used as			With bearing support	Nominal torques up to Nm	Bore up to mm	Page
	Backstops	Overrunning Clutch	Indexing Freewheel				
for bolting to the face							
FB with sprags, available in four types	●	●	●	●	160000	300	16
FR in inch dimension, with sprags available in four types	●	●	●	●	37000	180	18
FKh with hydrodynamic sprag lift-off		●		●	14000	95	20
with mounting flange							
FBF with sprags, available in four types	●	●	●	●	160000	300	22
FGR ... R A1A2 with rollers	●	●	●	●	68000	150	24
FGR ... R A2A7 with rollers	●	●	●	●	68000	150	26
for keyway connection on the outer ring							
BM with rollers or with sprag lift-off X	●	●		●	57500	150	28
FGRN ... R A5A6 with rollers	●	●	●	●	6800	80	30
with lever arm							
BA with rollers or with sprag lift-off X	●			●	57500	150	32
BC with rollers or with sprag lift-off X	●			●	57500	150	34
FGR ... R A3A4 with rollers	●			●	68000	150	36
FGR ... R A2A3 with rollers	●			●	68000	150	38
FRHD in inch dimension, with sprags	●			●	1215000	533	40
FA with sprags and grease lubrication	●		●	●	2500	85	42
FAV with rollers and grease lubrication	●		●	●	2500	80	44
with shaft coupling							
FBE for small shaft misalignments, with sprags		●		●	160000	300	46
FBL for large shaft misalignments, with sprags		●		●	8000	140	48
Housing Freewheels	Used as			With bearing support	Nominal torques up to Nm	Shaft up to mm	Page
	Backstops	Overrunning Clutch	Indexing Freewheel				
for stationary arrangement							
FH with hydrodynamic roller lift-off		●		●	40600	129	50
FCBM for rotary kiln drives	●			●	750	50	54
Basic Freewheels	Used as			With bearing support	Nominal torques up to Nm	Bore up to mm	Page
	Backstops	Overrunning Clutch	Indexing Freewheel				
for assembly with connecting parts							
FBO with sprags, available in four types	●	●	●	●	160000	300	56
FGR ... R with rollers	●	●	●	●	68000	150	58

Integrated Freewheels	Used as			With bearing support	Nominal torques up to Nm	Bore up to mm	Page
	Backstops	Overrunning Clutch	Indexing Freewheel				
for bolting to the face							
FXM with sprag lift-off X	●	●			1 230 000	560	60
FON with sprags, available in three types	●	●	●		25 000	155	66
for bolting to the face, with torque limiting							
FXRV with sprag lift-off X	●				100 000	300	68
FXRT with sprag lift-off X and with release function	●				53 000	240	68
Internal Freewheels	Used as			With bearing support	Nominal torques up to Nm	Bore up to mm	Page
	Backstops	Overrunning Clutch	Indexing Freewheel				
for press fit on the outer ring							
FXN with sprag lift-off X	●	●			20 500	130	72
FCN ... R with rollers	●	●	●		840	80	76
FDN with sprags	●	●	●	◐	2 400	80	78
FD with sprags	●	●	●	◐	2 400	105	80
ZZ with sprags and bearing support	●	●	●	◐	325	40	82
ZZ ... 2RS with sprags, bearing support and seals	●	●	●	◐	325	40	84
ZZ ... P2RS with sprags, bearing support and seals	●	●	●	◐	325	40	85
ZZ ... P with sprags and bearing support	●	●	●	◐	325	40	86
for keyway connection on the outer ring							
ZZ ... PP with sprags and bearing support	●	●	●	◐	325	40	87
FSN with rollers	●	●	●		3 000	80	88
FN with rollers	●	●	●		3 000	60	90
FNR with rollers and bearing support	●	●	●	◐	3 000	60	92
Cage Freewheels	Used as			With bearing support	Nominal torques up to Nm		Page
	Backstops	Overrunning Clutch	Indexing Freewheel				
for assembly with inner and outer ring							
SF with sprags, available in three types	●	●	●		93 000		94
SF ... P for high run out (T.I.R.), with sprags	●	●	●		5 800		96
BWX in inch dimension, with sprags	●	●	●		4 900		98
Irreversible Locks	Used as			With bearing support	Nominal torques up to Nm	Bore up to mm	Page
	Backstops	Overrunning Clutch	Indexing Freewheel				
bidirectional acting backstop for assembly with connecting parts							
Irreversible lock IR with rollers	●			◐	100	35	100
Freewheel technology details							Page
Application Examples and Special Freewheel Designs							102
Technical Points							106
Questionnaires							Page
for selecting RINGSPANN Backstops							110
for selecting RINGSPANN Overrunning Clutches							111
for selecting RINGSPANN Indexing Freewheels							112
for selecting RINGSPANN Housing Freewheels FH and FCBM							113

The maximum transmissible torques are 2 times the specified nominal torques.
Issue 01/2016 • Technical details subject to change without notice.

Freewheels are machine elements with particular characteristics:

- In one direction of rotation there is no contact between the inner and outer ring; the freewheel is in freewheeling operation.
- In the other direction of rotation there is contact between the inner and outer ring; in this direction it is possible to transmit high torque.

For example the outer ring of the freewheel shown in figure 4-1 can freewheel clockwise while the inner ring is stationary. If, however, the outer ring is turned in the opposite direction, there is contact between the inner and outer ring and the inner ring is driven (driving operation).

Freewheels are used as:

- ▶ Backstops
- ▶ Overrunning Clutches
- ▶ Indexing Freewheels

Freewheels can fulfill these functions completely automatically in the most diverse machines. No mechanical or hydraulic operating equipment is required, as for example with external actuated clutches or brakes.

Freewheels consist of an inner and an outer ring between which clamping elements are arranged. Clamping elements can be sprags or rollers. We differentiate as follows:

- Freewheels with bearing support and
- Freewheels without bearing support.

For a freewheel to function, the concentric alignment of the inner and outer ring is required. In the case of freewheels without bearing support, concentric alignment like this must be provided by the customer.

RINGSPANN freewheels are an indispensable design element in the machine building industry as well as in the aerospace industry. Many designs are only economical if freewheels are used. The freewheel as an automatic driving element is preferred to conventional solutions because it offers the following significant advantages:

- operating safety,
- efficiency and
- a higher degree of automation.

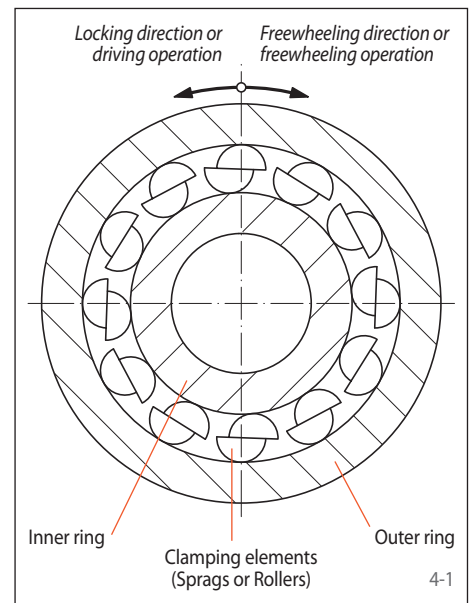

With more than 50 years experience in the development, production and sales of freewheels, RINGSPANN offers the most comprehensive range of freewheels. A global network of subsidiaries and sales agencies ensures the best possible personal on-site service. Assembly and production facilities in various countries provide fast, reliable delivery.

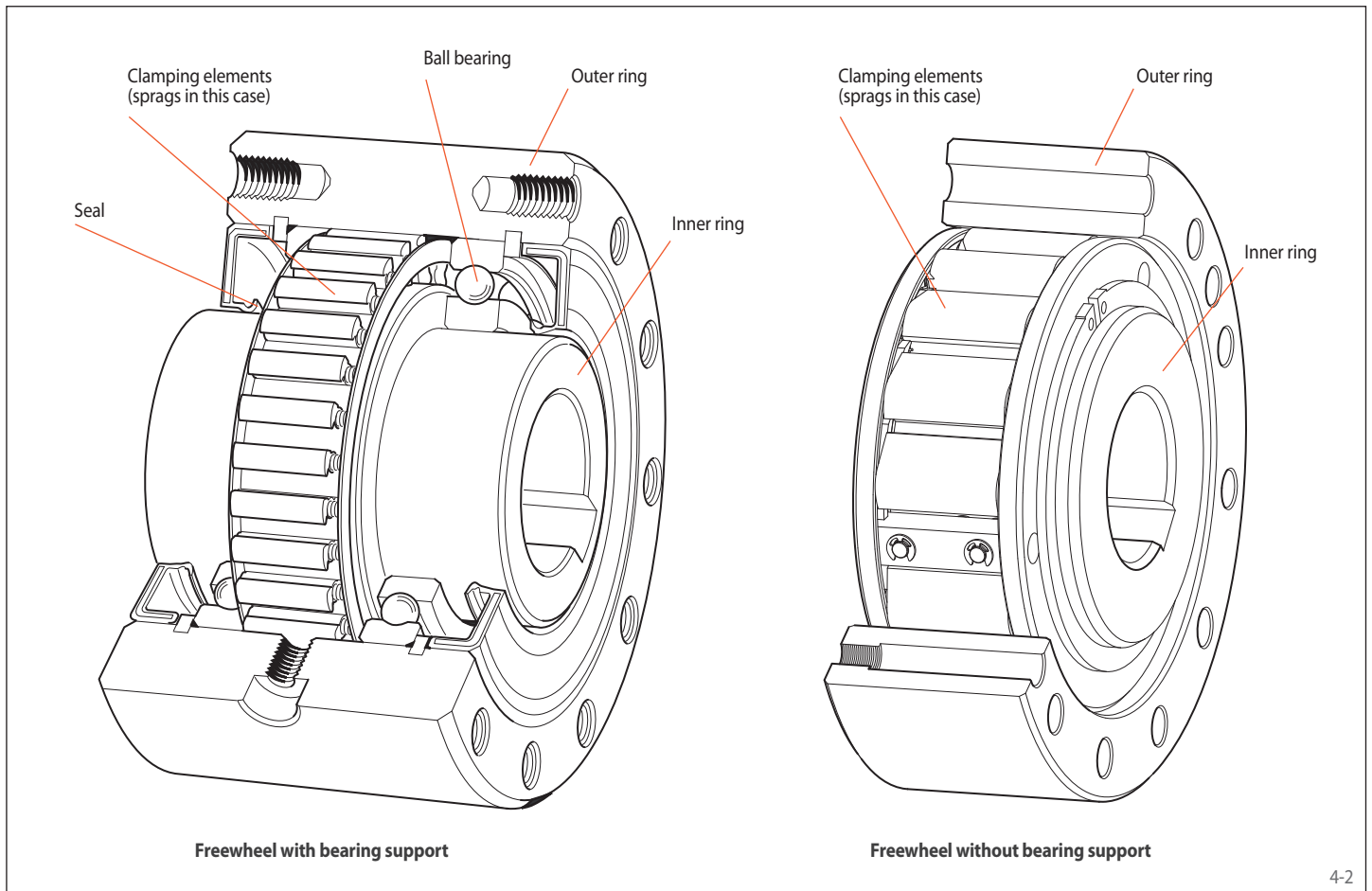

▶ Backstop

Freewheels are used as backstops if reverse rotation of the operating direction is to be prevented. In many machines and installations, for technical safety or functional reasons, it is necessary to ensure that you are working in just one specified direction of rotation. This is why there are legal stipulations requiring a mechanical safety device for the operation of, e.g. conveyor systems.

The normal operating mode of a backstop is freewheeling operation; the locking (torque transmission) is performed at zero speed. The immediate engagement of the clamping elements ensures the required high operating safety.

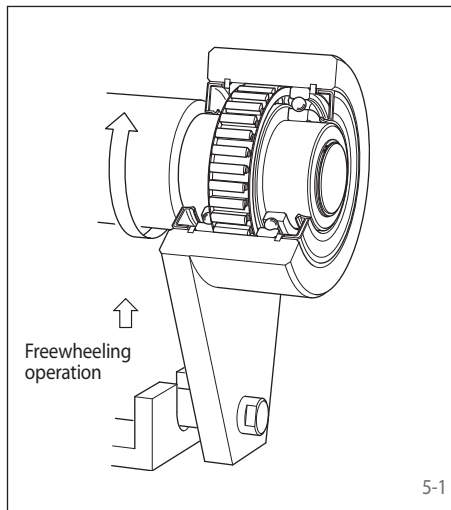

In general, backstops are used where the inner ring freewheels and the stationary held outer ring prevents reverse rotation (figure 5-1).

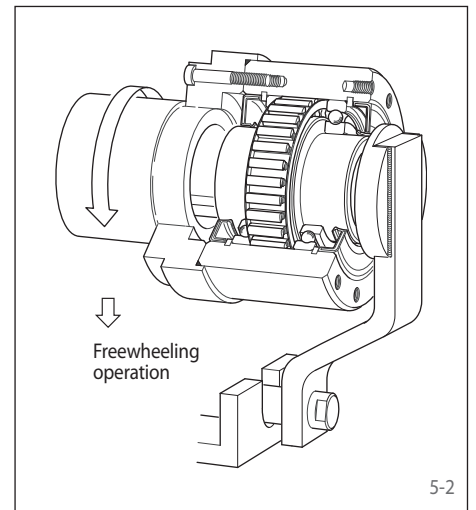

The more complicated designed backstops where the outer ring freewheels and the stationary held inner ring prevents reverse rotation are rarely used today (figure 5-2).

▶ Overrunning Clutch

The overrunning clutch engages machines or machine parts and automatically interrupts their contact as soon as the driven part of the overrunning clutch is turned faster than the driving part. In many cases, this can replace a more expensive externally actuated clutch.

With overrunning clutches the engagement takes place in the driving operation (torque transmission), while in freewheeling operation the torque transmission between the inner and outer ring is interrupted. In driving operation the speeds of the inner and outer ring are equal, while in freewheeling operation they are different.

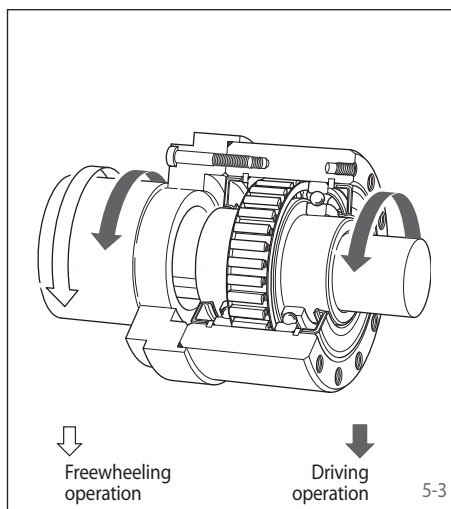

Figure 5-3 shows an overrunning clutch where in driving operation the power flow is transferred from the inner ring to the outer ring and in freewheeling operation the outer ring overruns the inner ring at a higher speed.

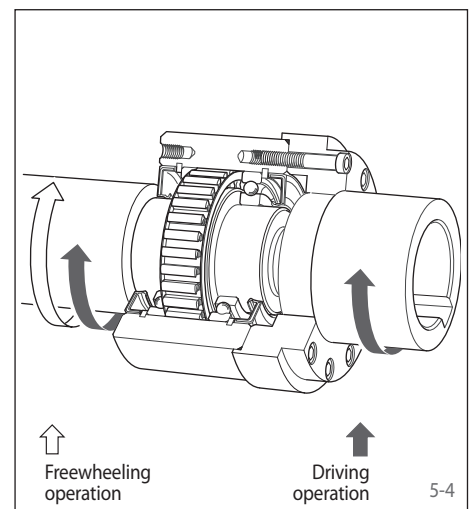

Figure 5-4 shows an overrunning clutch where in driving operation the power flow is transferred from the outer ring to the inner ring and in freewheeling operation the inner ring overruns the outer ring at a higher speed.

▶ Indexing Freewheel

The indexing freewheel transmits a back and forth motion into a stepped rotation (indexed feed). The RINGSPANN indexing freewheel works precisely and quietly and enables an infinitely adjustable setting of the feed.

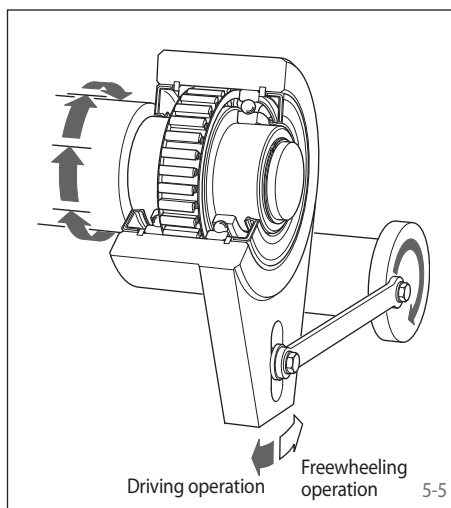

Figure 5-5 shows an indexing freewheel where the outer ring makes the back and forth motion and the inner ring carries out the indexed feed.

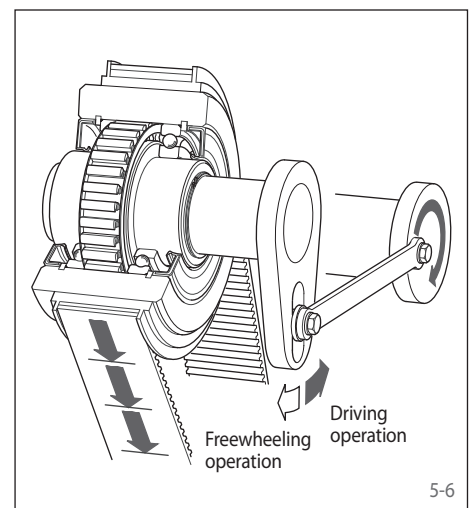
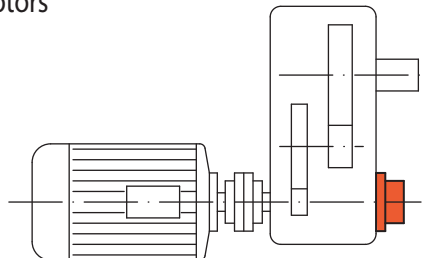

Figure 5-6 shows an indexing freewheel where the inner ring makes the back and forth motion and the outer ring carries out the indexed feed.

Areas of Application for Freewheels

Areas of application for Backstops

Gear units
Electric motors
Gear motors



The backstop prevents reverse rotation in a drive of a conveyor installation if the power fails or the motor is turned off.

Inclined conveyors
Elevators
Bucket elevators

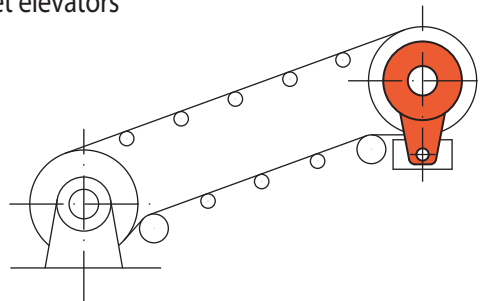

The backstop prevents reverse rotation of the conveyor load if the power fails or the motor is turned off.

Areas of application for Overrunning Clutches

Textile machines
Printing machines

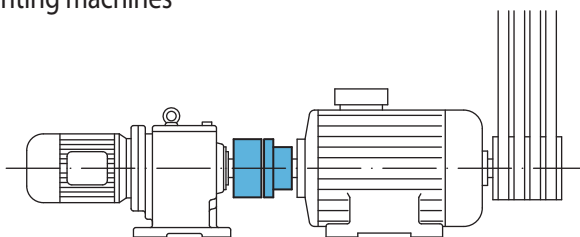

During normal operation of textile or printing machines, the overrunning clutch separates the barring drive which is used for set up from the main drive.

Fans
Ventilators

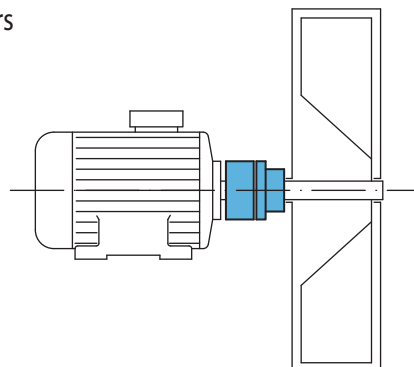

If fans or ventilators are turned off, the overrunning clutch prevents the flywheel mass from rotating the drive.

Areas of application for Indexing Freewheels

Textile machines
Printing machines

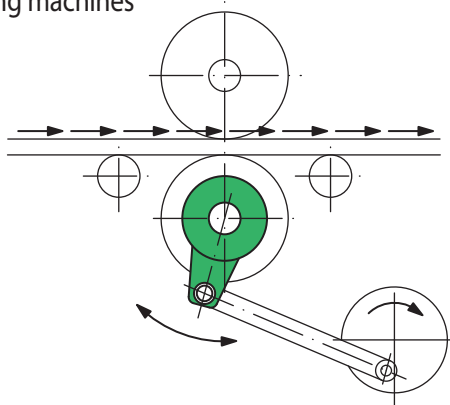

The indexing freewheel generates an indexed feed in textile and printing machines.

Packaging machines
Filling plants

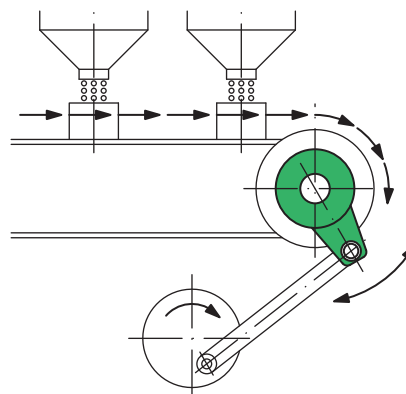

The indexing freewheel is used in packaging machines and filling plants for an indexed feed.

Fans
Ventilators

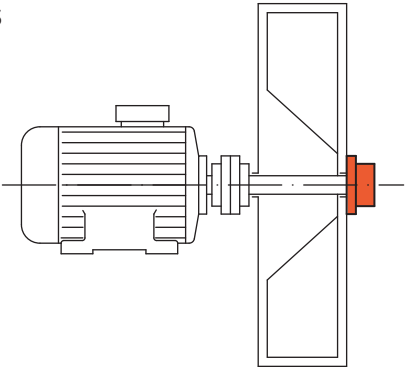

The backstop prevents reverse rotation under the back pressure of the conveyed medium if the motor is turned off.

Pumps
Compressors

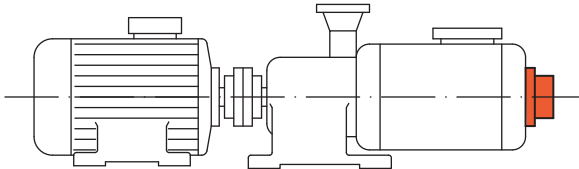

The backstop prevents reverse rotation under the back pressure of the conveyed medium if the motor is turned off.

Pumps
Generators

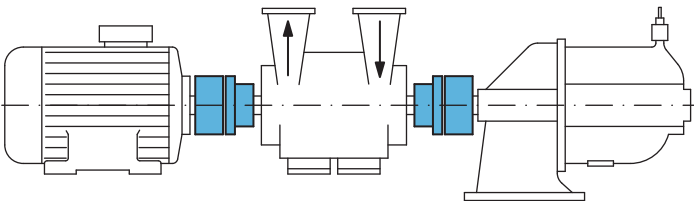

In multimotor drives the overrunning clutch disengages the inactive or lower speed drive.

Roller conveyor

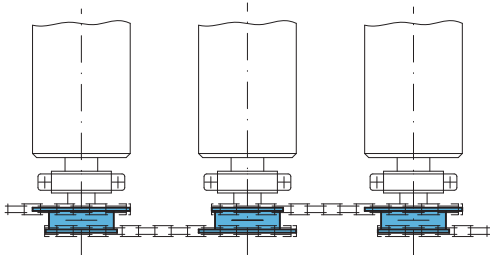

The overrunning clutch ensures that the conveyed material can be pushed or pulled faster over the rollers than the speed of the drive.

High voltage switches

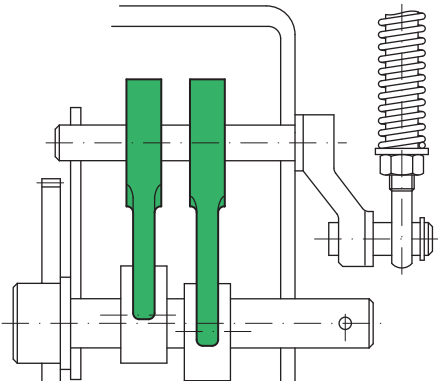

In high voltage switches for tensioning a spring, the indexing freewheel is used in the place of a reduction gear.

Seed spreader

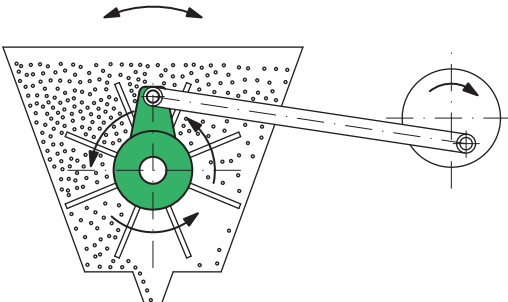

The indexing freewheel replaces a reduction gear in seed spreader.

Categories of Freewheels

Complete Freewheels

- With bearing support between inner and outer ring
- Completely enclosed
- With own lubrication
- Connection to the outer ring and the customer part by:
 - bolting to the face (figure 8-1),
 - mounting flange,
 - keyway connection on the outer ring,
 - lever arm (figure 8-2) or
 - shaft coupling.

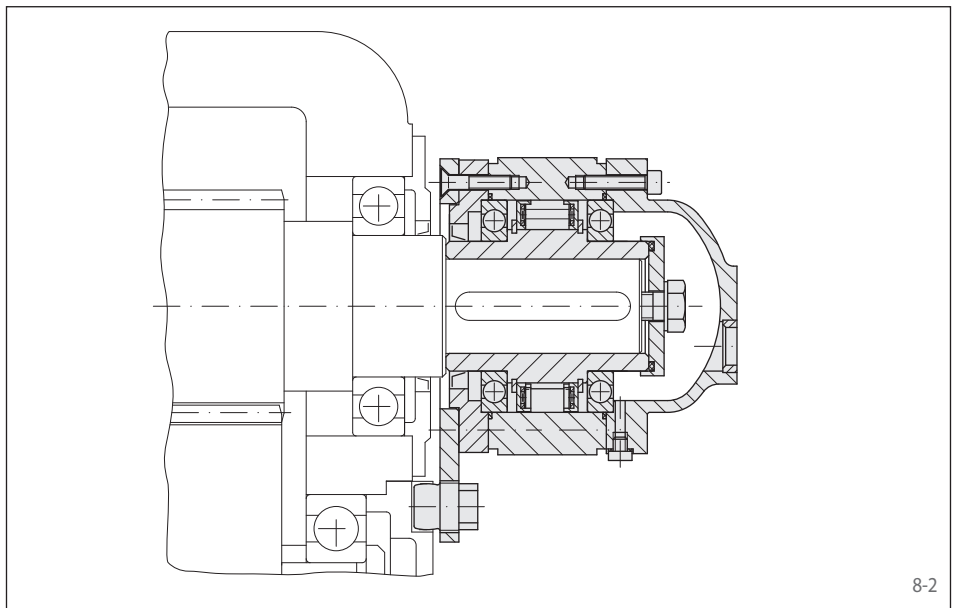
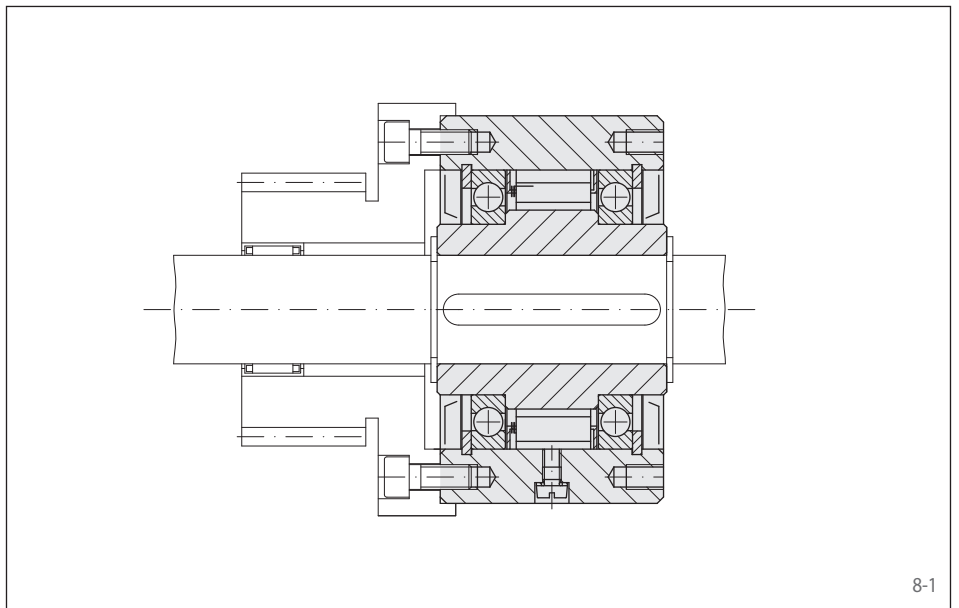

Housing Freewheels

- With bearing support between inner and outer ring
- Completely enclosed by its own housing
- With own lubrication
- With bearing supported input and output shafts
- Stationary arrangement

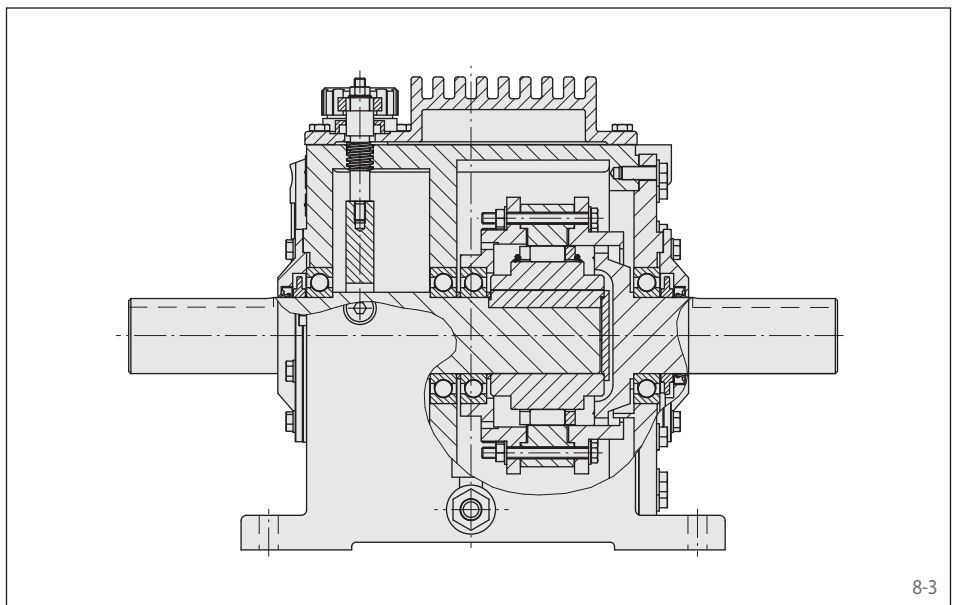

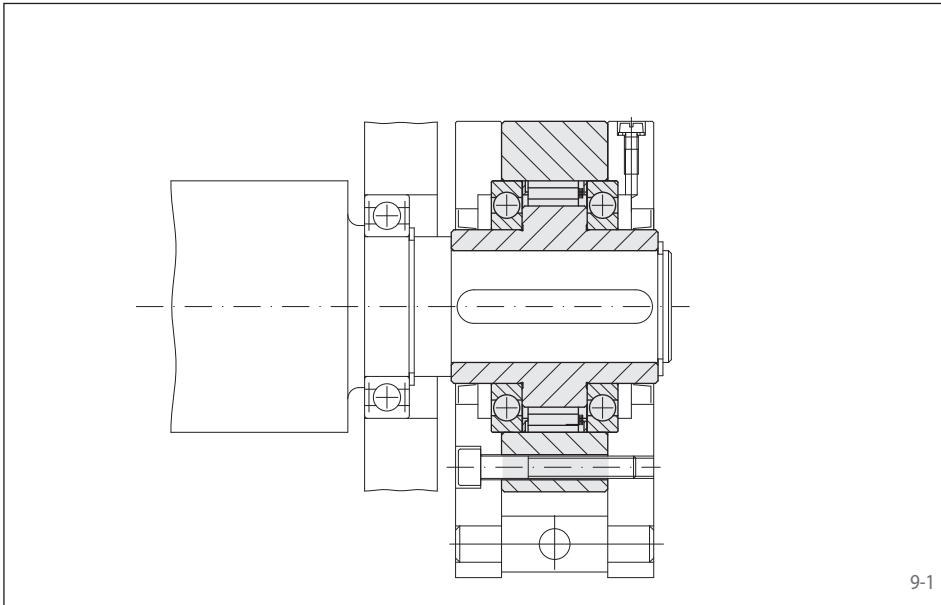

Basic Freewheels

- With bearing support between inner and outer ring
- For assembly with connecting parts
- Lubrication – if necessary – to be provided by the customer

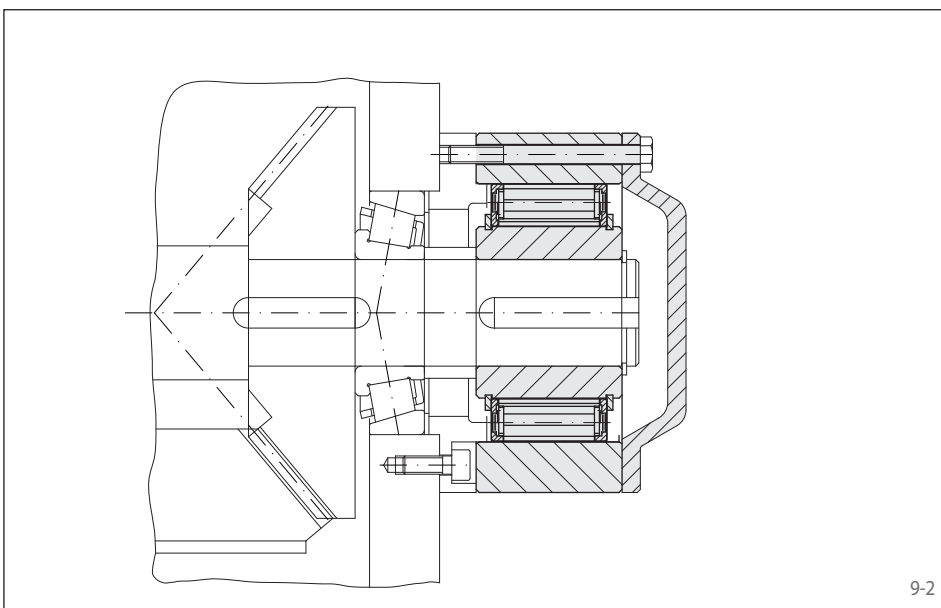

Integrated Freewheels

- Without bearing support. Concentric alignment of inner and outer ring must be provided by the customer
- Integrating the outer ring on the customer part by bolting to the face
- Lubrication – if necessary – to be provided by the customer

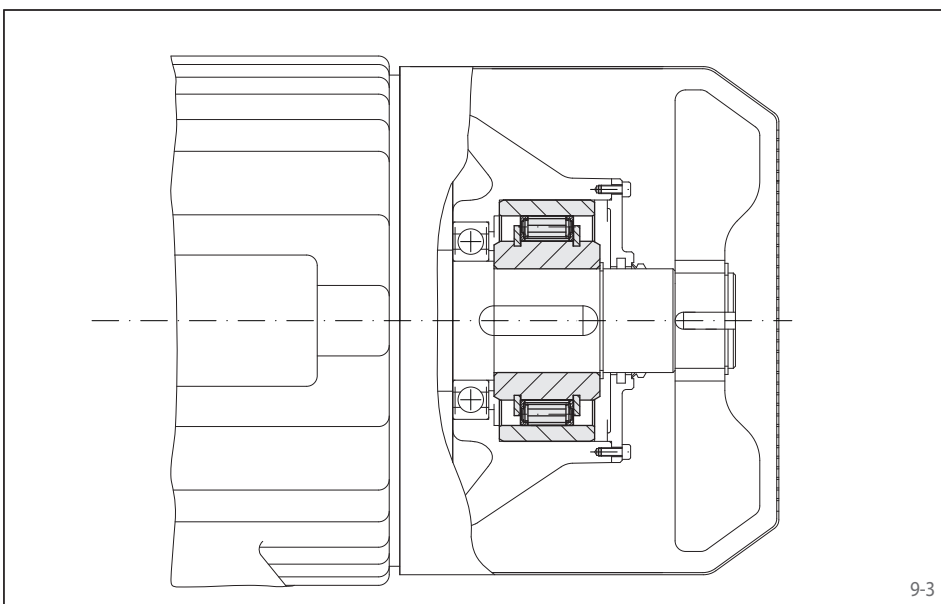

Internal Freewheels

- Series both with and without bearing support. In the case of series without bearing support, concentric alignment of the inner and outer ring must be provided by the customer
- Installing the outer ring in the customer's housing with press fit or keyway connection. This makes compact, space-saving solutions possible
- Lubrication – if necessary – to be provided by the customer

Freewheels with Sprags or Rollers

two different designs of freewheels

Design as Sprag Freewheel

The sprag freewheel has outer and inner rings with cylindrical tracks. The individually spring loaded sprags are arranged in between the rings. The freewheel locks without slipping. Different sprag profiles enable a multitude of types. Types are available for:

- High torques
- Contactless freewheeling operation
- High indexing accuracy

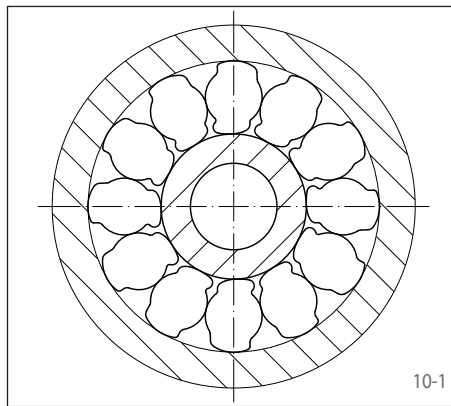

Function of Sprag Freewheels

With the sprag arrangement illustrated in figure 10-2 the outer ring can be turned freely clockwise (freewheeling operation), if the inner ring

- is at a standstill,
- is turned counterclockwise or
- is turned clockwise slower than the outer ring.

If the outer ring – e.g. with a stationary inner ring – is turned in the opposite direction, the clamping becomes effective. The sprags clamp without slipping between the tracks. In this direction of rotation high torque can be transmitted (driving operation).

The sprag arrangement in figure 10-2 also enables freewheeling operation while the inner ring is turned counterclockwise and driving operation when turning clockwise.

On the line of influence which links the points of contact of the sprag to the inner track and the sprag to the outer track, in driving operation the clamping generates the forces F_I and F_A (refer to figure 10-3). Because of the equilibrium of forces, these are equal. The forces F_I and F_A can be divided into the normal forces F_{NI} and F_{NA} as well as into the circumferential forces F_{TI} and F_{TA} . The line of influence forms against the force F_{NI} or F_{NA} the clamping angle ϵ_I or ϵ_A , whereby $\epsilon_I > \epsilon_A$. To achieve self-locking, the tangent of the clamping angle ϵ_I must be less than the friction value μ .

$$\tan \epsilon_I = \frac{F_{TI}}{F_{NI}} \leq \mu$$

Because of the relationship

$$\begin{aligned} M &= z \cdot R_I \cdot F_{TI} = z \cdot R_I \cdot F_{NI} \cdot \tan \epsilon_I \\ &= z \cdot R_A \cdot F_{TA} = z \cdot R_A \cdot F_{NA} \cdot \tan \epsilon_A \end{aligned}$$

with z = number of sprags

the normal forces and the clamping angles adapt automatically to the acting torque M .

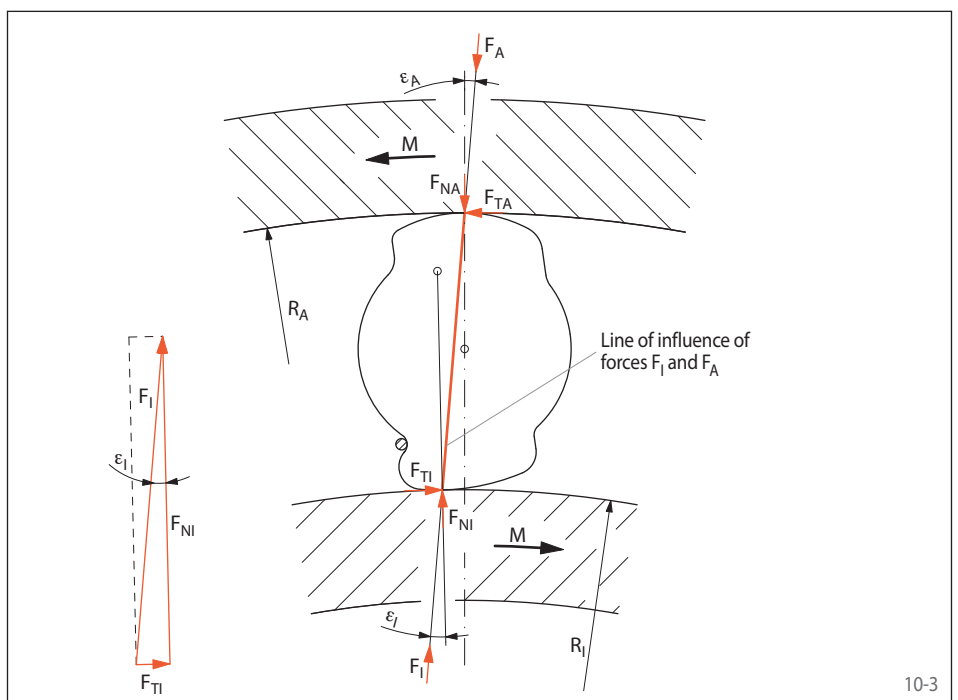
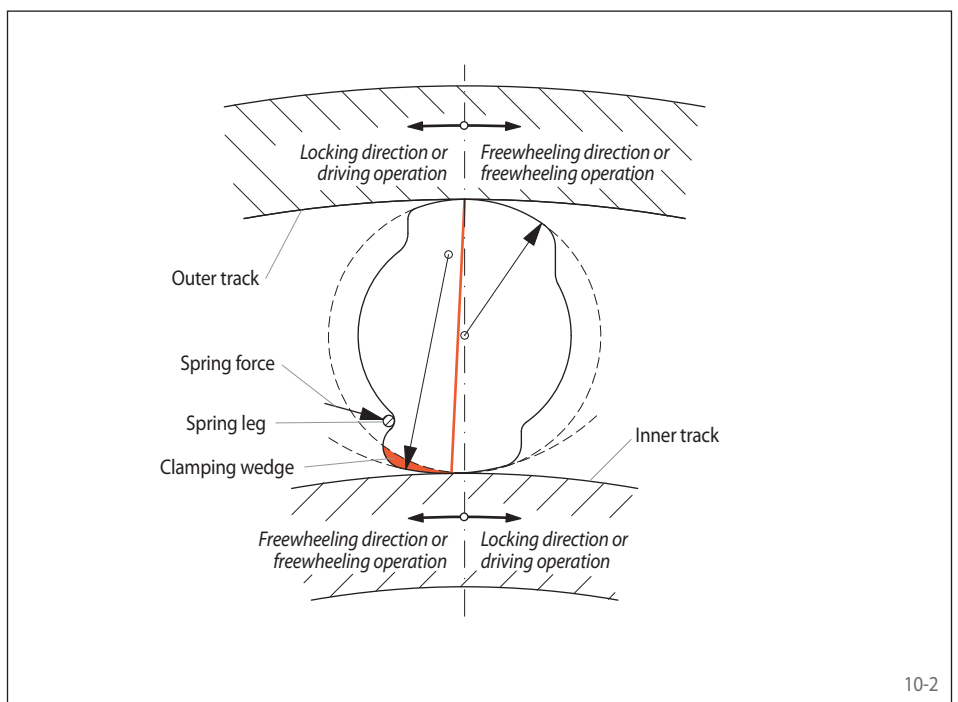

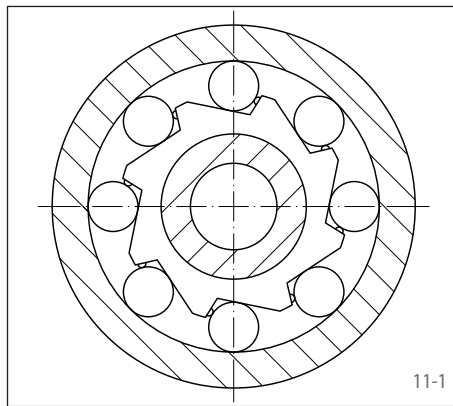

Design as a Roller Freewheel

With roller freewheels either the inner or the outer ring has roller ramps. The other ring has a cylindrical track. The individually spring loaded rollers are arranged in between the rings. The freewheel locks without slipping.

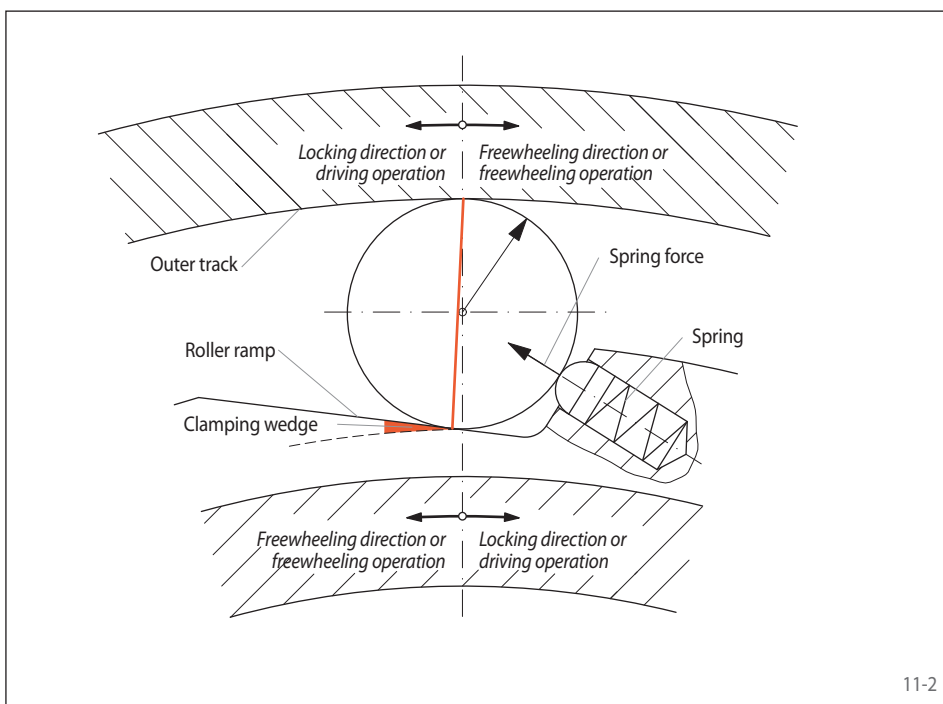

Function of Roller Freewheels

With the version illustrated in figure 11-2, the outer ring can be turned freely clockwise (freewheeling operation), if the inner ring

- is at a standstill,
- is turned counterclockwise or
- is turned clockwise slower than the outer ring.

If the outer ring – e.g. with a stationary inner ring – is turned in the opposite direction, the clamping becomes effective. The rollers clamp without slipping between the tracks. In this direction of rotation high torque can be transmitted (driving operation).

The version illustrated in figure 11-2 also enables a freewheeling operation while the inner ring is turned counterclockwise and driving operation when turning clockwise.

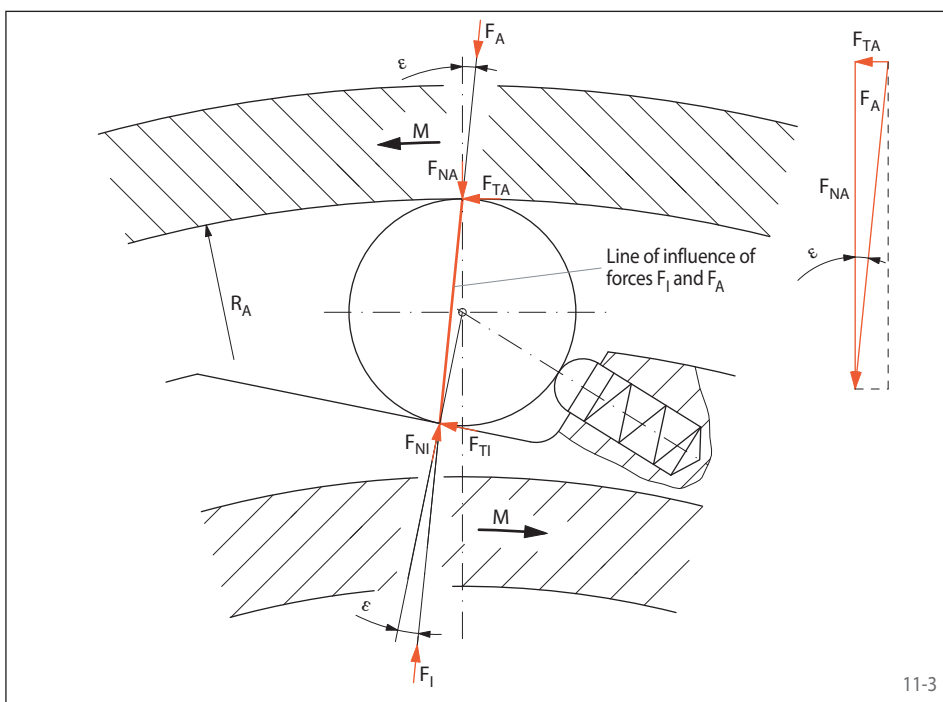

On the line of influence which links the points of contact of the roller to the roller ramp and the roller to the outer track, in driving operation the clamping generates the forces F_I and F_A (refer to figure 11-3). Because of the equilibrium of forces, these are equal. The forces F_I and F_A can be divided into the normal forces F_{NI} and F_{NA} as well as into the circumferential forces F_{TI} and F_{TA} . The line of influence forms against the force F_{NI} or F_{NA} the clamping angle ϵ . To achieve self-locking, the tangent of the clamping angle must be less than the friction value μ . E.g. for the contact point of the roller to the outer track this means:

$$\tan \epsilon = \frac{F_{TA}}{F_{NA}} \leq \mu$$

Because of the relationship

$$M = z \cdot R_A \cdot F_{TA} = z \cdot R_A \cdot F_{NA} \cdot \tan \epsilon$$

with z = number of rollers

the normal force and the clamping angle adapt automatically to the acting torque M .

Types for Extended Service Life

	Standard type	Type with sprag lift-off X	Type with sprag lift-off Z	Type with RIDUVIT®	Type with hydrodynamic sprag lift-off	
	For universal use	For extended service life using sprag lift-off at high speed rotating inner ring	For extended service life using sprag lift-off at high speed rotating outer ring	For extended service life using coated sprags	For extended service life using sprag lift-off at high speed rotating outer ring	
Use as	Backstop	Up to medium speeds during freewheeling operation (inner or outer ring freewheels)	Up to very high speeds during freewheeling operation (inner ring freewheels)	Up to very high speeds during freewheeling operation (outer ring freewheels)	Up to high speeds during freewheeling operation (inner or outer ring freewheels)	
	Overrunning Clutch	Up to medium speeds during freewheeling operation (inner or outer ring overruns) Up to very high speeds in driving operation (outer or inner ring drives)	Up to very high speeds during freewheeling operation (inner ring overruns) Low speeds in driving operation (outer ring drives)	Up to very high speeds during freewheeling operation (outer ring overruns) Low speeds in driving operation (inner ring drives)	Up to high speeds during freewheeling operation (inner or outer ring overruns) Up to very high speeds in driving operation (outer or inner ring drives)	Up to very high speeds during freewheeling operation (outer ring overruns) Up to very high speeds in driving operation (inner ring drives)
	Indexing Freewheel	Up to a medium total number of actuations			Up to a high total number of actuations	

In addition the standard type, RINGSPANN has developed four other types for extended ser-

vice life for freewheels with sprags. The table above lists the recommended application

conditions for these types.

Type with sprag lift-off X

The sprag lift-off X is used for backstops and overrunning clutches, provided that in freewheeling operation the inner ring is rotating at high speed and providing with overrunning clutches that the driving operation is conducted at low speed. In freewheeling operation, the centrifugal force F_C causes the sprag to lift off from the outer track. In this operating state, the freewheel works wear-free, i.e. with unlimited service life.

Figure 12-1 shows a freewheel with sprag lift-off X in freewheeling operation. The sprags, which are supported in a cage connected with the inner ring, rotate with the inner ring. The centrifugal force F_C that is applied in the center of gravity S of the sprag turns the sprag counterclockwise and rests against the support ring of the cage. This results in the gap a between

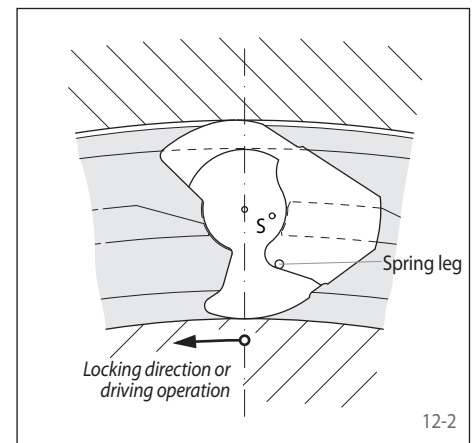
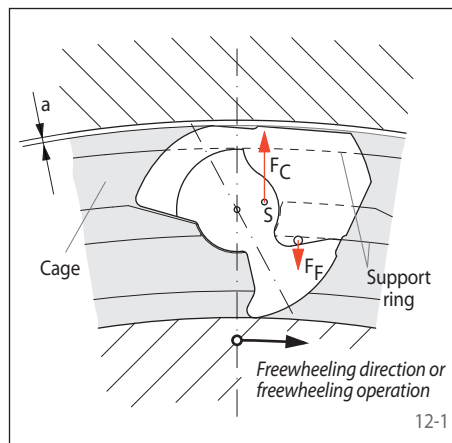

the sprag and the outer track; the freewheel works without contact. If the inner ring speed decreases to such an extent that the effect of the centrifugal force on the sprag is less than that of the spring force F_F , the sprag again rests

on the outer ring and the freewheel is ready to lock (figure 12-2). If used as an overrunning clutch, the driving speed must not exceed 40% of the lift-off speed.

Type with sprag lift-off Z

The sprag lift-off Z is applied for backstops and overrunning clutches, provided in freewheeling operation the outer ring is rotating at high speed, and providing with overrunning clutches the driving operation is conducted at low speed. In freewheeling operation, the centrifugal force F_C causes the sprag to lift off from the inner track. In this operating state, the freewheel works wear-free, i.e. with unrestricted service life.

Figure 12-3 shows a freewheel with sprag lift-off Z in freewheeling operation. The sprags rotate with the outer ring. The centrifugal force F_C that is applied in the centre of gravity S of the sprag turns the sprag counterclockwise and rests against the outer ring. This results in the gap a between the sprag and the inner track;

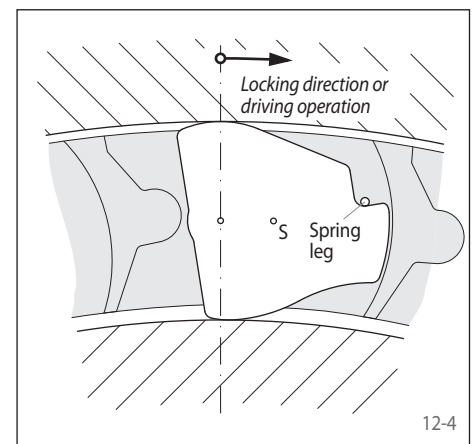
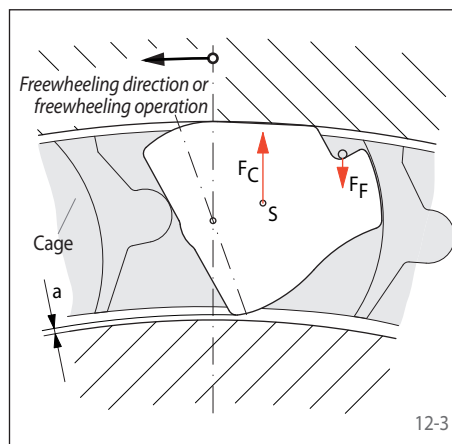

the freewheel works without contact. If the outer ring speed decreases to such an extent that the effect of the centrifugal force on the sprag is less than that of the spring force F_F , the

sprag again rests on the inner ring and the freewheel is ready to lock (figure 12-4). If used as an overrunning clutch, the driving speed must not exceed 40% of the lift-off speed.

Type RIDUVIT®

RINGSPANN sprags are made from chrome steel, the same material as used for the balls in ball bearings. The high compressive strength, elasticity and tensile strength of this material is required for the sprags in a locked state. In freewheeling operation, however, it is able to cope with utmost wear resistance on the points of contact of the sprag with the inner track. All of these requirements are perfectly fulfilled by using a chrome steel sprag with RIDUVIT® coating. The RIDUVIT® coating lends the sprag a resistance to wear akin to that of hard metal. The technology used here is based on state-of-

the-art tribology research. RIDUVIT® sprags are used in backstops and overrunning clutches and considerably increase the service life.

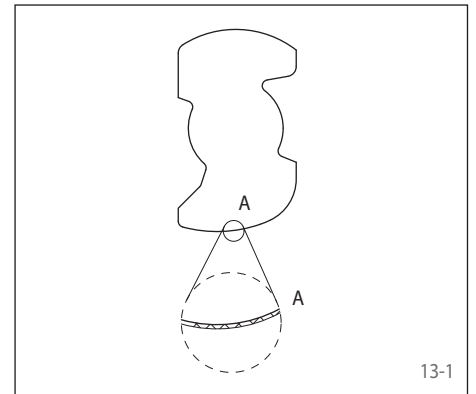

13-1

Type with hydrodynamic sprag lift-off

The hydrodynamic sprag lift-off is the ideal solution for overrunning clutches at high speeds, not only in freewheeling operation, but also in the driving operation, as can occur, for example, in multimotor drives. In the case of the hydrodynamic sprag lift-off, the lifting force is generated by an oil flow. The relative speed between the inner and outer rings is decisive for the lifting-off function. Compared to the freewheels with sprag lift-off X or Z, here the driving speed can be just as high as the freewheeling speed.

The freewheels with hydrodynamic sprag lift-off (series FK_h) include an oil pump that is based on the pitot tube principle. The pitot tubes are connected with the inner ring. When the outer ring is rotating, an oil ring forms in the oil chamber, into which the pitot tubes are immersed. As soon as the outer ring overruns the inner ring, the pitot tubes pump the oil under pressure into the ring chamber and the oil then seeps out through the ring gap at high speed axially into the intermediate areas of the sprags. Depending on the relative speed between the outer and inner ring, the oil flow does not flow

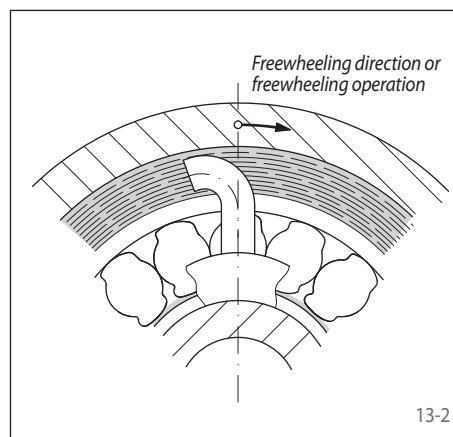

13-2

axially into the intermediate areas of the sprags, but at an angle. This creates a reaction force on the sprags. This reaction force overcomes the contact force of the sprag springs, and the sprags lift off from the inner ring. This process is supported by a hydrodynamic wedge formation. If the relative speed between the outer and inner rings reduces, the lifting force also reduces. Before achieving synchronous running, the sprags are brought safely to rest on the inner ring and are ready to lock. This

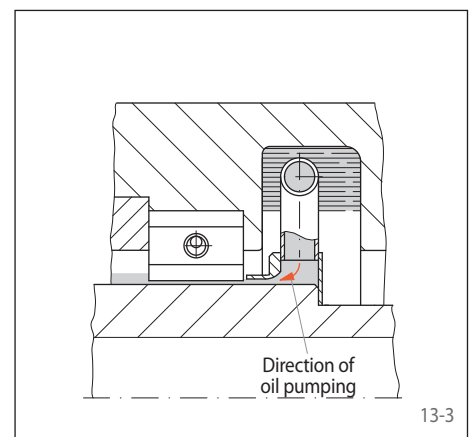

13-3

guarantees immediate torque transfer once the synchronous speed has been reached. The hydrodynamic sprag lift-off enables a virtually wear-free freewheeling operation.

Selection torque for Backstops

Bringing a loaded inclined conveyor, an elevator or a pump to a standstill is a highly dynamic process that incurs high peak torques. These peak torques are decisive for the selection of the backstop. The prior determination of the occurring torque in the case of locking is carried out most safely by using a rotational vibration analysis of the entire system. This, however, requires a knowledge of the rotating masses, the rotational rigidity and all of the excitation moments that occur on the system. In many cases, a vibrational calculation is too time consuming or you may not have all the necessary data in the configuration phase available. In this case, the selection torque M_A of the backstop should be determined as follows:

$$M_A = 1,75 \cdot M_L \text{ [Nm]}$$

Often you only have the figures for the motor nominal output P_0 [kW] available. Then:

$$M_A = 1,75 \cdot F^2 \cdot 9550 \cdot P_0 / n_{SP} \text{ [Nm]}$$

In these equations:

$$M_A = \text{Selection torque of the backstop [Nm]}$$

$$M_L = 9550 \cdot F \cdot P_L / n_{SP} \text{ [Nm]}$$

= Static backdriving torque of the load referring to the backstop shaft [Nm]

$$P_L = \text{Lifting capacity of the conveyor system at full load [kW]}$$

= Lifting height [m] multiplied by the load that is being conveyed per second [kN/s]

$$P_0 = \text{Nominal power of motor [kW]}$$

$$n_{SP} = \text{Speed of backstop shaft [min}^{-1}\text{]}$$

$$F = \text{Selection factor (refer to table)}$$

After calculating M_A the backstop size must be selected in accordance with the catalogue tables in such a way that in all cases this applies:

$$M_N \geq M_A$$

$$M_N = \text{Nominal torque of the backstop in accordance with the table values [Nm]}$$

It must be noted that, with a direct motor start in the locking direction of a backstop, very high peak torques can occur which in turn can destroy the backstop.

Approximate values for F:

Type of installation	F	F ²
Conveyor belts, angle up to 6°	0,71	0,50
Conveyor belts, angle up to 8°	0,78	0,61
Conveyor belts, angle up to 10°	0,83	0,69
Conveyor belts, angle up to 12°	0,86	0,74
Conveyor belts, angle up to 15°	0,89	0,79
Screw pumps	0,93	0,87
Ball mills, drying drums	0,85	0,72
Bucket conveyors, elevators	0,92	0,85
Hammer mills	0,93	0,87
Fans, Ventilators	0,53	0,28

Selection torque for Overrunning Clutches

In many cases where overrunning clutches are being used, dynamic processes occur that cause high peak torques. In the case of overrunning clutches, the torques that occur during start up must be observed. The peak torques when starting up can, in the case of asynchronous motors – especially when accelerating large masses and when using elastic couplings – significantly exceed the torque calculated from the motor pull-over torque. The conditions for internal combustion engines are similar. Even in normal operation, on account of their degree of irregularity, peak torques can occur that are way in excess of the nominal torque.

The prior determination of the maximum occurring torque is carried out most safely by using a rotational vibration analysis of the entire system. This, however, requires a knowledge of the rotating masses, the rotational rigidity and all of the excitation moments that occur on the system. In many cases, a vibrational calculation is too time consuming or you may not have all the necessary data in the configuration phase available. In this case, the selection torque M_A of the overrunning clutch should be determined as follows:

$$M_A = K \cdot M_L$$

In this equation:

$$M_A = \text{Selection torque of the freewheel}$$

$$K = \text{Operating factor (refer to table)}$$

$$M_L = \text{Load torque for constant rotating freewheel:}$$

$$= 9550 \cdot P_0 / n_{FR}$$

$$P_0 = \text{Nominal power of motor [kW]}$$

$$n_{FR} = \text{Speed of the freewheel in driving operation [min}^{-1}\text{]}$$

After calculating M_A the freewheel size must be selected in accordance with the catalogue tables in such a way that in all cases this applies:

$$M_N \geq M_A$$

$$M_N = \text{Nominal torque of the freewheel in accordance with the table values [Nm]}$$

Approximate values for operating factor K:

Type of driver	K
Electric motors with low start up impact (e.g. DC motors, asynchronous motors with slip rings or soft start couplings), steam turbines, gas turbines	0.8 to 2.5
Electric motors with considerable start up impact (e.g. synchronous or asynchronous motors with direct start)	1.25 to 2.5
Piston engines with more than two cylinders, water turbines, hydraulic motors	1.25 to 3.15
Piston engines with one or two cylinders	1.6 to 3.15

The operating factor K depends on the properties of the driver and the machine. The general rules of mechanical engineering apply here. We know from practice that applications are known where the operating factor K can also assume values of up to 20, e.g. with a direct start-up of asynchronous electric motors in connection with elastic couplings.

Selection torque for Indexing Freewheels

The selection torque for indexing freewheels is, among other things, dependent upon how the back and forth motion is generated (crank

operation, hydraulic cylinders, pneumatic cylinders etc.). It cannot be specified in a simple equation. When stating the maximum torque

to be transmitted, we are happy to advise you regarding the selection torque.

The selection of the correct freewheel depends on several criteria. In order to make an optimum freewheel selection for you, we ask that you complete the respective questionnaire on pages 110 to 114 and send it to us.

If you wish to select the freewheel yourself, then we recommend - without liability for possible errors that could occur during selection - that you proceed as follows:

1. Determine the application of the Freewheel as a

- ▶ Backstop
- ▶ Overrunning Clutch
- ▶ Indexing Freewheel

Refer to page 5.

2. Determine the suitable category of the Freewheel as

- Complete Freewheel,
- Housing Freewheel,
- Basic Freewheel,
- Integrated Freewheel or
- Internal Freewheel.

Refer to pages 8 and 9.

3. Determine the selection torque of the Freewheel.

Refer to page 14.

The nominal torques, specified in the catalogue are designed for the application of freewheels on solid shafts and the specified minimum thickness of the housing or the outer rings. When using freewheels on hollow shafts or with lower outer wall thickness, the transmissible torque should be checked by RINGSPANN.

4. Determine the suitable type of the Freewheel as

- Standard type,
- Type with sprag lift-off X
- Type with sprag lift-off Z
- Type with RIDUVIT®
- Type with hydrodynamic sprag lift-off

Refer to pages 12 and 13.

5. Choose the suitable Freewheel

Refer to the table of contents on pages 2 and 3, the representations of the different series on pages 16 to 101 as well as the technical points on pages 106 to 109.

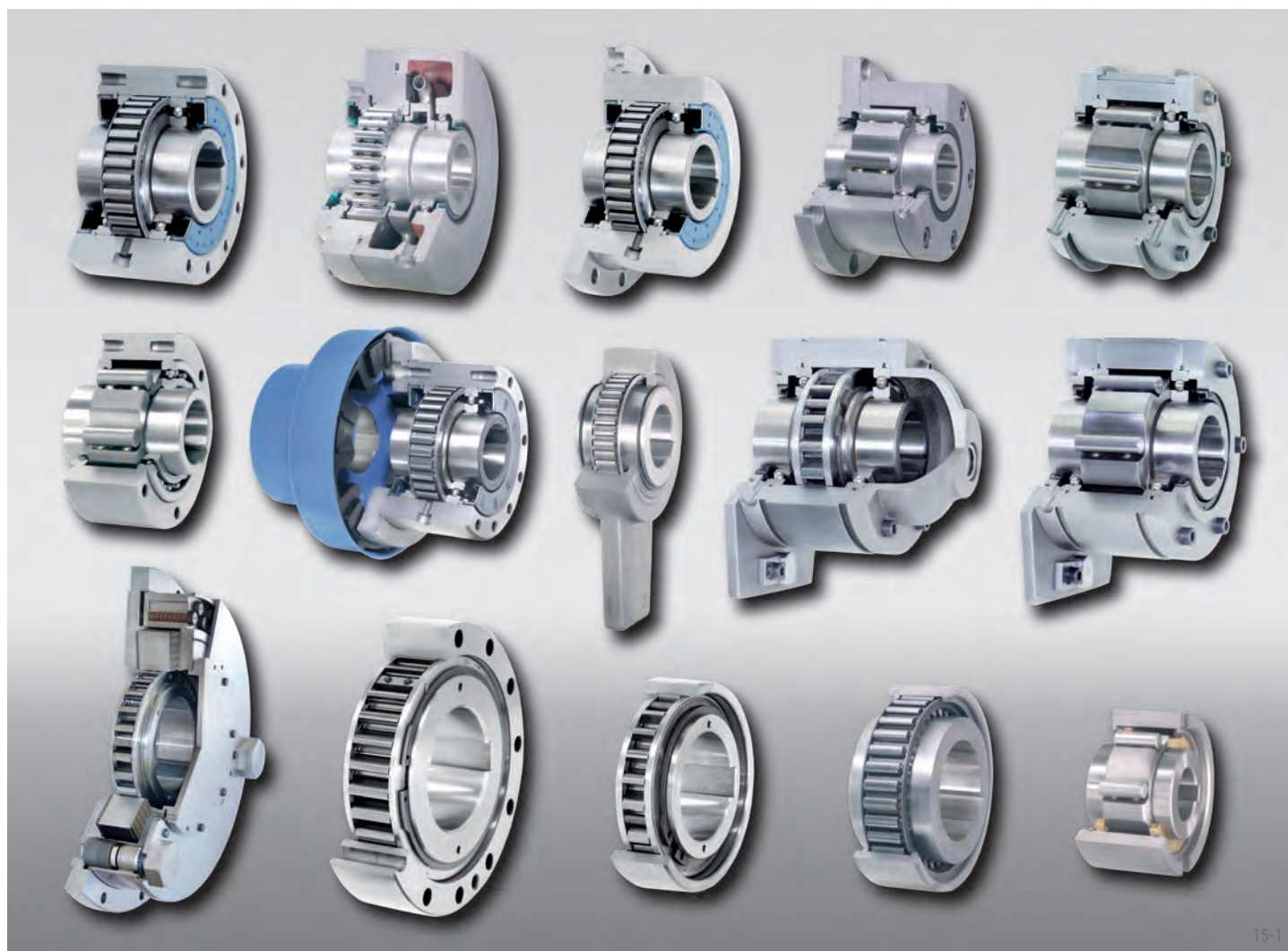

Complete Freewheels FB

for bolting to the face
with sprags, available in four types

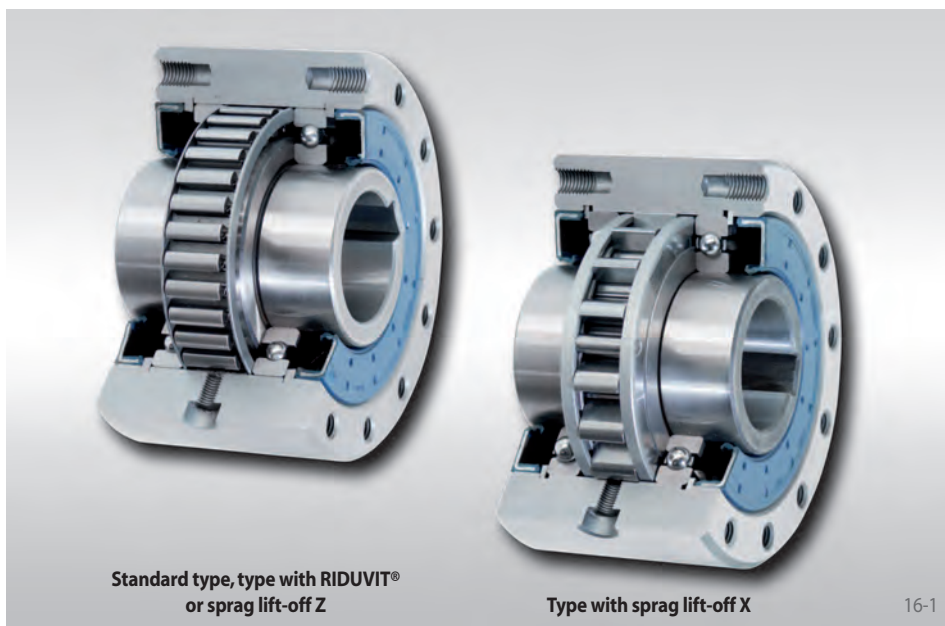

Standard type, type with RIDUVIT®
or sprag lift-off Z

Type with sprag lift-off X

16-1

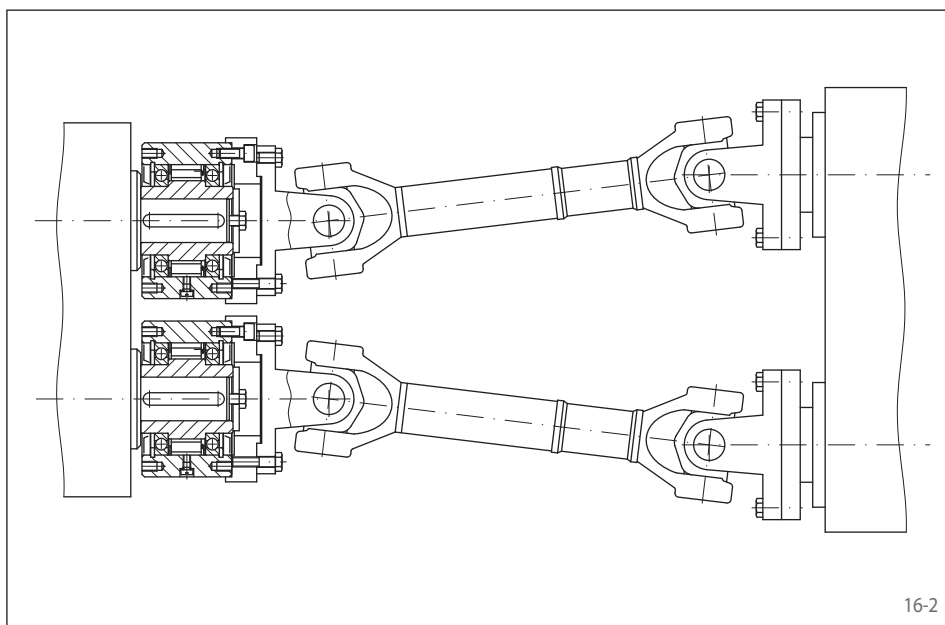

16-2

Application as

- ▶ Backstop
- ▶ Overrunning Clutch
- ▶ Indexing Freewheel

Features

Complete Freewheels FB are sealed sprag freewheels with ball bearings. They are supplied oil-filled and ready for installation.

In addition to the standard type, three other types are available for extended service life.

Nominal torques up to 160 000 Nm.

Bores up to 300 mm. A multitude of standardized bore diameters are available with short delivery times.

Application example

Two Complete Freewheels FB 82 SFT as overrunning clutches in the drive of an edge trimming shear in a wide strip roll train. When trimming the edges of the strip, the trimming rollers are driven by the drive of the edge trimming shear. By doing so, the two freewheels work in driving operation. As soon as the sheet metal strip is gripped by the next pair of rollers, they pull the strip at an increased speed and the inner rings overrun the slower turning drive of the edge trimming shear. By doing so, the freewheels work in freewheeling operation. The RIDUVIT® sprags give the freewheels an extended service life.

Mounting

The customer attachment part is on the external diameter D and then bolted on to the face.

The tolerance of the shaft must be ISO h6 or j6 and the tolerance of the pilot diameter D of the attachment part must be ISO H7 or J7.

Example for ordering

Freewheel size FB 72, type with sprag lift-off Z and 40 mm bore:

- FB 72 LZ, $d = 40$ mm

When ordering freewheel size FB 340 and FB 440, please also specify the freewheeling direction of the inner ring when viewed in direction X:

- counterclockwise free or
- clockwise free

Complete Freewheels FB

for bolting to the face
with sprags, available in four types

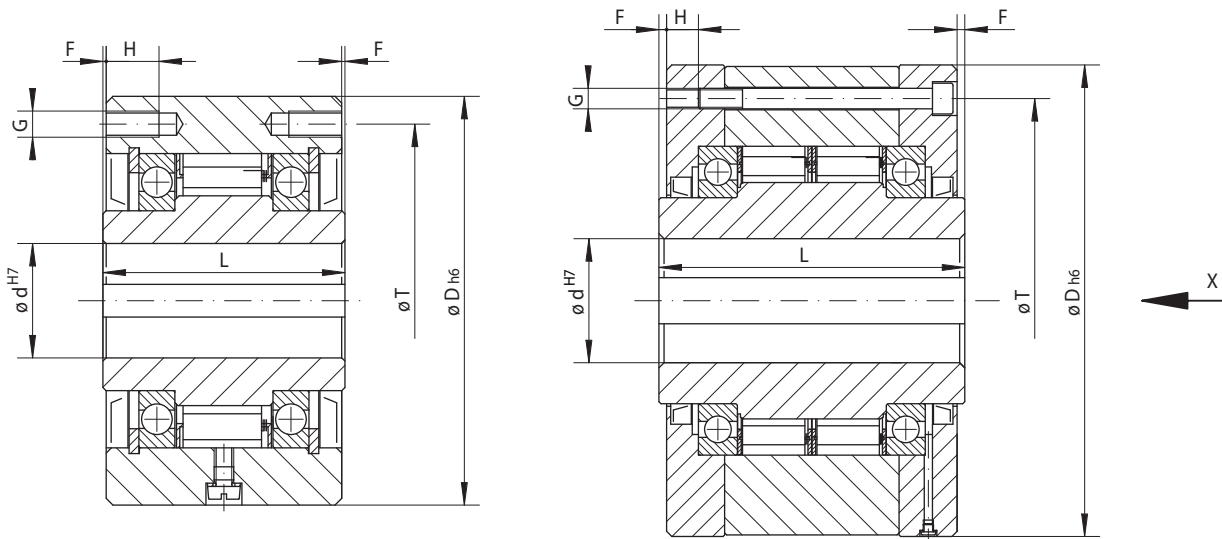

Size FB 24 to FB 270

17-1

Size FB 340 to FB 440

17-2

Indexing Freewheel	Standard type For universal use	Type with RIDUVIT® For extended service life using coated sprags	Type with sprag lift-off X For extended service life using sprag lift-off at high speed rotating inner ring	Type with sprag lift-off Z For extended service life using sprag lift-off at high speed rotating outer ring
Overrunning Clutch				
Backstop				

Freewheel Size	Type	Nominal torque M _N Nm	Max. speed		Type	Nominal torque M _N Nm	Max. speed		Type	Nominal torque M _N Nm	Sprag lift-off at inner ring speed min ⁻¹	Max. speed		Type	Nominal torque M _N Nm	Sprag lift-off at outer ring speed min ⁻¹	Max. speed	
			Inner ring freewheels/ overruns min ⁻¹	Outer ring freewheels/ overruns min ⁻¹			Inner ring freewheels/ overruns min ⁻¹	Outer ring freewheels/ overruns min ⁻¹				Inner ring freewheels/ overruns min ⁻¹	Outer ring drives min ⁻¹					
FB 24	CF	45	4 800	5 500	CFT	45	4 800	5 500										
FB 29	CF	80	3 500	4 000	CFT	80	3 500	4 000										
FB 37	SF	200	2 500	2 600	SFT	200	2 500	2 600										
FB 44	SF	320	1 900	2 200	SFT	320	1 900	2 200	DX	130	860	1 900	344	CZ	110	850	3 000	340
FB 57	SF	630	1 400	1 750	SFT	630	1 400	1 750	DX	460	750	1 400	300	LZ	430	1 400	2 100	560
FB 72	SF	1 250	1 120	1 600	SFT	1 250	1 120	1 600	DX	720	700	1 150	280	LZ	760	1 220	1 800	488
FB 82	SF	1 800	1 025	1 450	SFT	1 800	1 025	1 450	DX	1 000	670	1 050	268	SFZ	1 700	1 450	1 600	580
FB 107	SF	2 500	880	1 250	SFT	2 500	880	1 250	DX	1 500	610	900	244	SFZ	2 500	1 300	1 350	520
FB 127	SF	5 000	800	1 150	SFT	5 000	800	1 150	SX	3 400	380	800	152	SFZ	5 000	1 200	1 200	480
FB 140	SF	10 000	750	1 100	SFT	10 000	750	1 100	SX	7 500	320	750	128	SFZ	10 000	950	1 150	380
FB 200	SF	20 000	630	900	SFT	20 000	630	900	SX	23 000	240	630	96	SFZ	20 000	680	900	272
FB 270	SF	40 000	510	750	SFT	40 000	510	750	UX	40 000	210	510	84	SFZ	37 500	600	750	240
FB 340	SF	80 000	460	630	SFT	80 000	460	630										
FB 440	SF	160 000	400	550	SFT	160 000	400	550										

The maximum transmissible torque is 2 times the specified nominal torque. See page 14 for determination of selection torque.

Freewheel Size	Bore d		D	F	G**	H	L	T	Z**	Weight
	Standard mm	max. mm								
FB 24	12	14*	62	1,0	M 5	8	50	51	3	0,9
FB 29	15	17*	68	1,0	M 5	8	52	56	3	1,1
FB 37	20	22*	75	0,5	M 6	10	48	65	4	1,3
FB 44	25*	25*	90	0,5	M 6	10	50	75	6	1,9
FB 57	30	32*	100	0,5	M 8	12	65	88	6	2,8
FB 72	40	42*	125	1,0	M 8	12	74	108	12	5,0
FB 82	50*	50*	135	2,0	M 10	16	75	115	12	5,8
FB 107	60	65*	170	2,5	M 10	16	90	150	10	11,0
FB 127	70	75*	200	3,0	M 12	18	112	180	12	19,0
FB 140	90	95*	250	5,0	M 16	25	150	225	12	42,0
FB 200	120	120	300	5,0	M 16	25	160	270	16	62,0
FB 270	140	150	400	6,0	M 20	30	212	360	18	150,0
FB 340	180	240	500	7,5	M 20	35	265	450	24	275,0
FB 440	220	300	630	7,5	M 30	40	315	560	24	510,0

Freewheels with bore diameters highlighted blue in the table are available with short delivery times.

Keyway according to DIN 6885, page 1 • Tolerance of keyway width JS10.

* Keyway according to DIN 6885, page 3 • Tolerance of keyway width JS10.

** Z = Number of tapped holes G on pitch circle T.

Complete Freewheels FR ...

for bolting to the face
in inch dimension, with sprags available in four types



Application as

- ▶ Backstop
- ▶ Overrunning Clutch
- ▶ Indexing Freewheel

Features

Complete Freewheels FR ... are sealed sprag freewheels in inch dimension with ball bearings. They are supplied oil-filled and ready for installation.

In addition to the standard type, three other types are available for extended service life.

Nominal torques up to 27 500 lb-ft.

Bores up to 7 inch. Many standard bores are available.

Application example

Complete Freewheels FRS 600 in both drive units of a transport system with a conveyor belt that moves both forward and backward (reversible operation). In order to ensure that the conveyor belt is moved under tension, forward movement is driven by drive unit I, reverse movement by drive unit II. The freewheels automatically disengage the respective non working drive, eliminating the need for expensive external clutches or brakes.

For forward movement, drive unit II is started in freewheeling direction of freewheel II; freewheel II is in freewheeling operation and disengages drive unit II from the conveyor belt. Afterwards drive unit I is started in the locking direction of the freewheel I; freewheel I is in driving operation and the conveyor belt is moved forward by drive unit I. The speed of drive unit I is lower than that of drive unit II. Thus freewheel II remains in freewheeling operation and drive unit II is not improperly engaged.

For reverse movement, the drive units are started in reverse order and direction of rotation at the corresponding speeds.

Mounting

The customer attachment part is centered on the external diameter D and then bolted on to the face.

The tolerance of the shaft must be + 0 / - 0,001 inch and the tolerance of the pilot diameter D of the attachment part must be - 0 / + 0,002 inch.

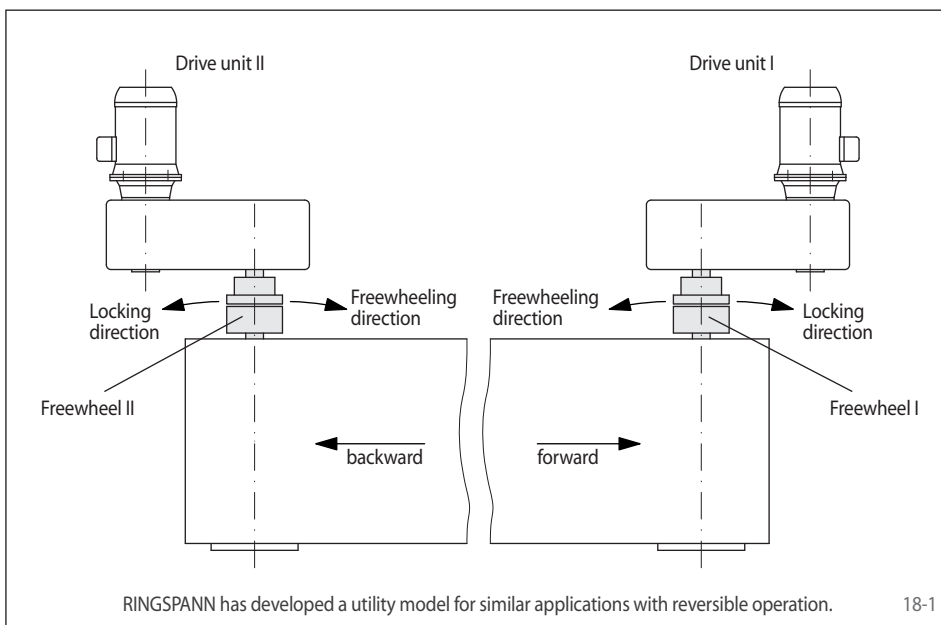

Standard bores and keyway sizes [inch]									
FR ... 300	0,500	0,625	0,750						
	1/8 x 1/16	3/16 x 3/32	3/16 x 3/32						
FR ... 400	0,500	0,625	0,750	0,875	1,000	1,125			
	1/8 x 1/16	3/16 x 3/32	3/16 x 3/32	3/16 x 3/32	1/4 x 1/8	1/4 x 1/8			
FR ... 500	0,875	1,000	1,125	1,250	1,312				
	3/16 x 3/32	1/4 x 1/8	1/4 x 1/8	1/4 x 1/8	1/4 x 3/32				
FR ... 550	1,250	1,312	1,500	1,625					
	1/4 x 1/8	3/8 x 3/16	3/8 x 3/16	3/8 x 1/8					
FR ... 600	1,250	1,375	1,438	1,500	1,625	1,688	1,750	1,938	2,000
	1/4 x 1/8	3/8 x 3/16	3/8 x 3/16	3/8 x 3/16	3/8 x 3/16	3/8 x 3/16	3/8 x 3/16	3/8 x 1/8	3/8 x 1/8
FR ... 650	1,938	2,000	2,250	2,438	2,500				
	1/2 x 1/4	1/2 x 1/4	1/2 x 1/4	5/8 x 1/8	5/8 x 1/8				
FR ... 700	1,938	2,000	2,250	2,438	2,500	2,750	2,938		
	1/2 x 1/4	1/2 x 1/4	1/2 x 1/4	5/8 x 5/16	5/8 x 5/16	5/8 x 7/32	5/8 x 1/8		
FR ... 750	2,438	2,500	2,938	3,000	3,250	3,438			
	5/8 x 5/16	5/8 x 5/16	3/4 x 3/8	3/4 x 3/8	3/4 x 3/8	3/4 x 1/8			
FR ... 775	2,750	2,938	3,000	3,250	3,438	3,500	3,750		
	5/8 x 5/16	3/4 x 3/8	3/4 x 3/8	3/4 x 3/8	7/8 x 5/16	7/8 x 5/16	7/8 x 1/4		
FR ... 800	3,000	3,250	3,438	3,500	3,750	3,937	4,000	4,250	4,500
	3/4 x 3/8	3/4 x 3/8	7/8 x 7/16	7/8 x 7/16	7/8 x 7/16	1 x 1/2	1 x 1/2	1 x 3/8	1 x 1/4
FR ... 900	4,000	4,438	4,500	4,938	5,000	5,438			
	1 x 1/2	1 x 1/2	1 x 1/2	1 1/4 x 5/16	1 1/4 x 5/16	1 1/4 x 5/16			
FR ... 1000	5,750	5,938	6,000	6,750	6,875	7,000			
	1 1/2 x 3/4	1 1/2 x 3/4	1 1/2 x 3/4	1 3/4 x 7/16	1 3/4 x 7/16	1 3/4 x 7/16			

for bolting to the face
in inch dimension, with sprags available in four types

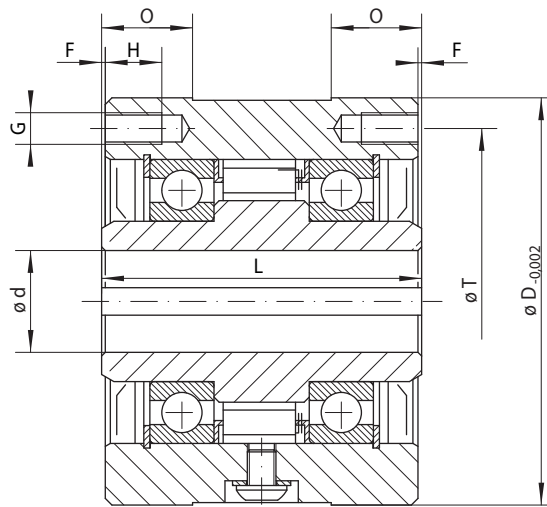

19-1

Indexing Freewheel Overrunning Clutch Backstop	Standard type For universal use	Standard type - grease lubricated For universal use	Type with sprag lift-off X For extended service life using sprag lift-off at high speed rotating inner ring	Type with sprag lift-off Z For extended service life using sprag lift-off at high speed rotating outer ring

Freewheel Size	Nominal torque M _N lb-ft	Max. speed		Freewheel Size	Nominal torque M _N lb-ft	Max. speed		Freewheel Size	Nominal torque M _N lb-ft	Sprag lift-off at inner ring speed min ⁻¹	Max. speed		Freewheel Size	Nominal torque M _N lb-ft	Sprag lift-off at outer ring speed min ⁻¹	Max. speed	
		Inner ring freewheels/ overruns min ⁻¹	Outer ring freewheels/ overruns min ⁻¹			Inner ring freewheels/ overruns min ⁻¹	Outer ring freewheels/ overruns min ⁻¹				Inner ring freewheels/ overruns min ⁻¹	Outer ring freewheels/ overruns min ⁻¹					
FRS 300	210	2500	2600	FRSG 300	210	3600	3600	FRX 400	125	860	4000	340	FRZ 400	280	800	2600	320
FRS 400	335	1900	2100	FRSG 400	335	3600	3600	FRX 500	425	750	4000	300	FRZ 500	535	1400	2050	560
FRS 500	800	1400	1900	FRSG 500	800	3600	3600	FRX 550	750	700	4000	280	FRZ 550	1380	1550	1800	620
FRS 550	1525	1175	1600	FRSG 550	1525	3600	3600	FRX 600	1000	670	4000	265	FRZ 600	1765	1450	1650	580
FRS 600	1950	1100	1500	FRSG 600	1950	3600	3600	FRX 650	1750	610	4000	240	FRZ 650	2500	1300	1400	520
FRS 650	2700	900	1250	FRSG 650	2700	3600	3600	FRX 700	4050	350	3600	140	FRZ 700	5250	1160	1200	465
FRS 700	5525	790	1150	FRSG 700	5525	1800	1800	FRX 750	7500	320	2400	125	FRZ 750	8750	1160	1200	465
FRS 750	9350	790	1150	FRSG 750	9350	1800	1800	FRX 775	7400	320	2100	125	FRZ 775	6500	950	1050	380
FRS 775	8500	750	1050	FRSG 775	8500	1800	1800	FRX 800	14500	250	1800	100	FRZ 800	8700	880	975	350
FRS 800	11100	700	950	FRSG 800	11100	1800	1800	FRX 900	15000	250	650	100	FRZ 900	13000	720	925	288
FRS 900	16800	700	950	FRSG 900	16800	1200	1200										
FRS 1000	27500	630	800	FRSG 1000	27500	1200	1200										

The maximum transmissible torque is 2 times the specified nominal torque. See page 14 for determination of selection torque.

Freewheel Size	Bore d										D	F	G	L	H	O	T	Z*	Weight	
	Standard bores inch																			max. inch
FR ... 300	0,500	0,650	0,750								0,750	3,000	0,063	0,250-28	2,500	0,375	0,750	2,625	4	3,5
FR ... 400	0,500	0,625	0,750	0,875	1,000	1,125					1,125	3,500	0,032	0,312-24	2,750	0,500	0,750	2,875	4	6,0
FR ... 500	0,875	1,000	1,125	1,250	1,312						1,312	4,250	0,063	0,312-24	3,500	0,625	1,000	3,625	4	10,0
FR ... 550	1,250	1,312	1,500	1,625							1,625	4,750	0,063	0,312-24	3,250	0,540	0,750	4,250	6	12,0
FR ... 600	1,250	1,375	1,438	1,500	1,625	1,688	1,750	1,938	2,000	2,000	5,375	0,063	0,312-24	3,750	0,625	1,000	4,750	6	19,0	
FR ... 650	1,938	2,000	2,250	2,438	2,500					2,500	6,500	0,063	0,375-24	3,500	0,750	1,000	5,750	8	24,0	
FR ... 700	1,938	2,000	2,250	2,438	2,500	2,750	2,938			2,938	7,125	0,063	0,375-24	5,000	0,750	1,000	6,250	8**	42,0	
FR ... 750	2,438	2,500	2,938	3,000	3,250	3,438				3,438	8,750	0,063	0,500-20	6,000	0,875	1,250	7,000	8**	83,0	
FR ... 775	2,750	2,938	3,000	3,250	3,438	3,500	3,750			3,750	9,750	0,063	0,500-20	6,000	0,875	1,250	8,500	8	96,0	
FR ... 800	3,000	3,250	3,438	3,500	3,750	3,937	4,000	4,250	4,500	4,500	10,000	0,063	0,500-20	6,000	0,875	1,250	8,937	8	102,0	
FR ... 900	4,000	4,438	4,500	4,938	5,000	5,438				5,438	12,000	0,063	0,625-18	6,375	1,000	1,375	9,750	10	156,0	
FR ... 1000	5,750	5,938	6,000	6,750	6,875	7,000				7,000	15,000	0,063	0,625-18	6,625	1,000	1,375	11,750	12	250,0	

* Z = Number of tapped holes G on pitch circle T.

** Six holes are equally spaced 60° apart with two additional holes located 30° from the six equally spaced holes and 180° apart.

Conversion factors: 1 lb-ft = 1,35 Nm, 1 inch = 25,4 mm, 1 lbs = 0,453 kg.

Example for ordering

Freewheel size FR ... 700, type with sprag lift-off Z and 2 inch bore:

- FRZ 700, d = 2 inch

Complete Freewheels FKh

for bolting to the face
with hydrodynamic sprag lift-off for multimotor drives

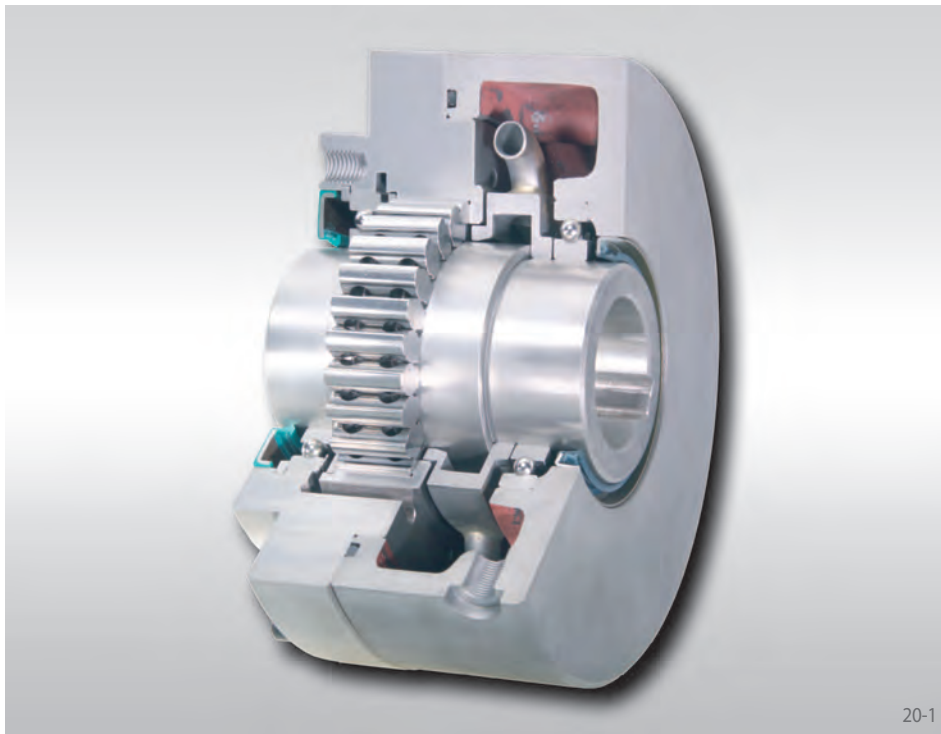

Application as

▶ Overrunning Clutch

at high speeds, which are the same or similar in freewheeling operation and in driving operation.

Features

Complete Freewheels FKh with hydrodynamic sprag lift-off are typically used in installations where an assembly can be driven from two or more motors or turbines at the same or similar high speed.

Complete Freewheels FKh are sealed sprag freewheels with ball bearings. They are supplied oil-filled and ready for installation.

Nominal torques up to 14 000 Nm.

Bores up to 95 mm.

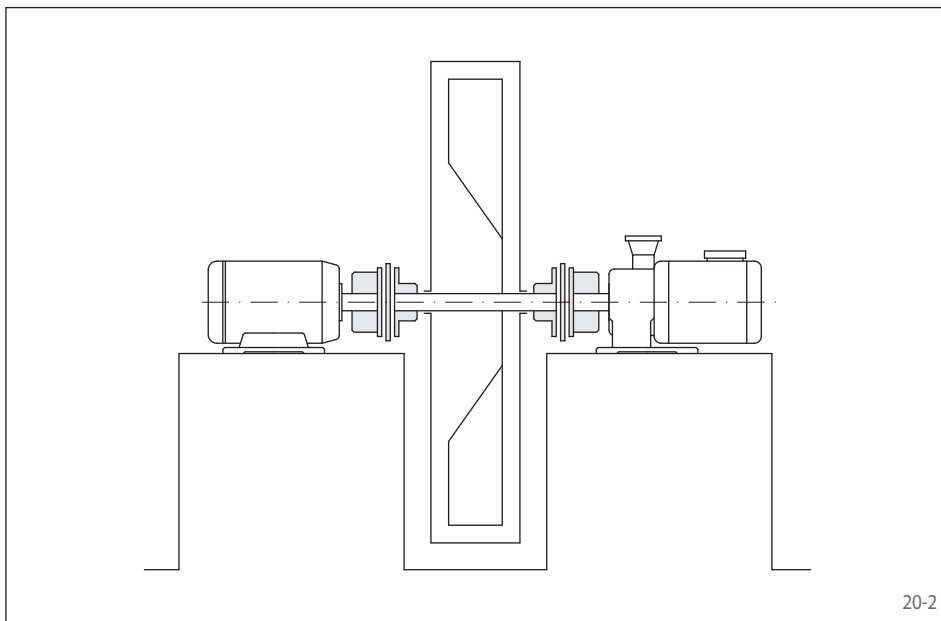

Application example

Two Complete Freewheels FKh 28 ATR as overrunning clutches in the drive system of a fan. The fan can be driven either by an electric motor or by a turbine. The freewheels between the fan and the two drive assemblies automatically engage the working drive with the fan and in each case disengage the drive that is no longer giving power. The freewheels replace actuated clutches, which require an additional activation when changing over from one drive to another. The hydrodynamic sprag lift-off is the most suitable type for a wear-free freewheeling operation if the speeds in driving operation are the same or similarly high to those speeds in freewheeling operation.

for bolting to the face
with hydrodynamic sprag lift-off for multimotor drives

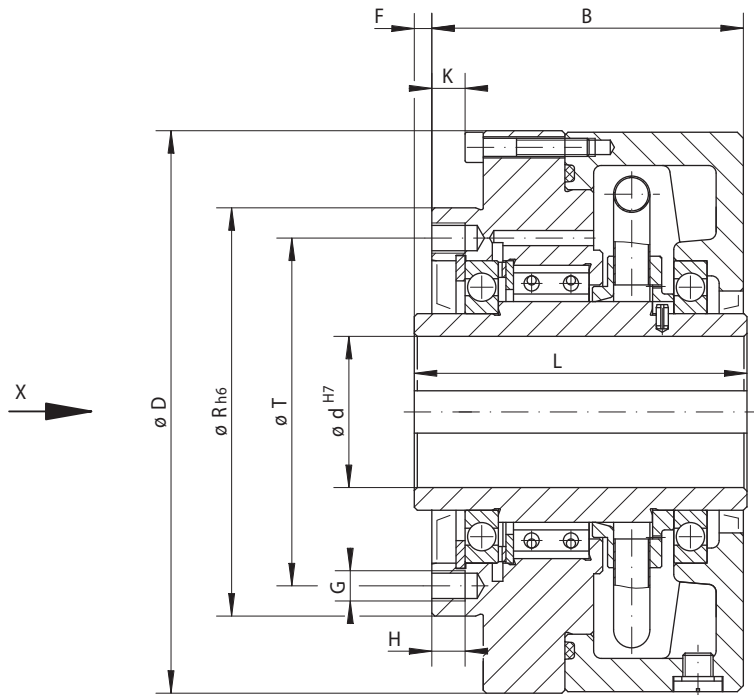

21-1

		Type with hydrodynamic sprag lift-off For extended service life using sprag lift-off at high speed rotating outer ring				Dimensions											
Freewheel Size	Type	Nominal torque M_N Nm	Max. speed		Bore d		B mm	D mm	F mm	G** mm	H mm	K mm	L mm	R mm	T mm	Z**	Weight kg
			Outer ring overruns min^{-1}	Inner ring drives min^{-1}	Standard mm	max. mm											
FKh 24	ATR	1 100	3 000	3 000	35	40*	90	170	1,0	M 10	11	9	95	135	115	6	9,6
FKh 28	ATR	1 800	2 000	2 000	45	50*	103	186	1,0	M 10	11	11	105	135	115	12	14,0
FKh 94	ATR	2 500	1 800	1 800	60	60	112	210	7,0	M 10	16	9	120	170	150	10	19,0
FKh 106	ATR	4 200	1 600	1 600	70	75*	116	250	7,5	M 12	18	8	125	200	180	12	25,0
FKh 148	ATR	7 000	1 600	1 600	80	95*	156	291	7,5	M 16	25	9	165	250	225	12	52,0
FKh 2.53	ATR	14 000	1 600	1 600	90	95*	241	345	2,0	M 16	25	6	245	250	220	16	98,0

The maximum transmissible torque is 2 times the specified nominal torque. See page 14 for determination of selection torque.

Keyway according to DIN 6885, page 1 • Tolerance of keyway width JS10.

* Keyway according to DIN 6885, page 3 • Tolerance of keyway width JS10.

** Z = Number of tapped holes G on pitch circle T.

Mounting

The customer attachment part is centered on the diameter R and then bolted on to the face.

The installation must invariably take place in such a way that the drive (driving operation) is carried out via the inner ring and the outer ring overruns in freewheeling operation.

The tolerance of the shaft must be ISO h6 or j6 and the tolerance of the pilot diameter R of the attachment part must be ISO H7 or J7.

Example for ordering

Freewheel size FKh 28, type with hydrodynamic sprag lift-off and 45 mm bore:

- FKh 28 ATR, d = 45 mm

When ordering, please also specify the freewheel direction of the outer ring when viewed in direction X:

- counterclockwise free or
- clockwise free

Complete Freewheels FBF

with mounting flange
with sprags, available in four types

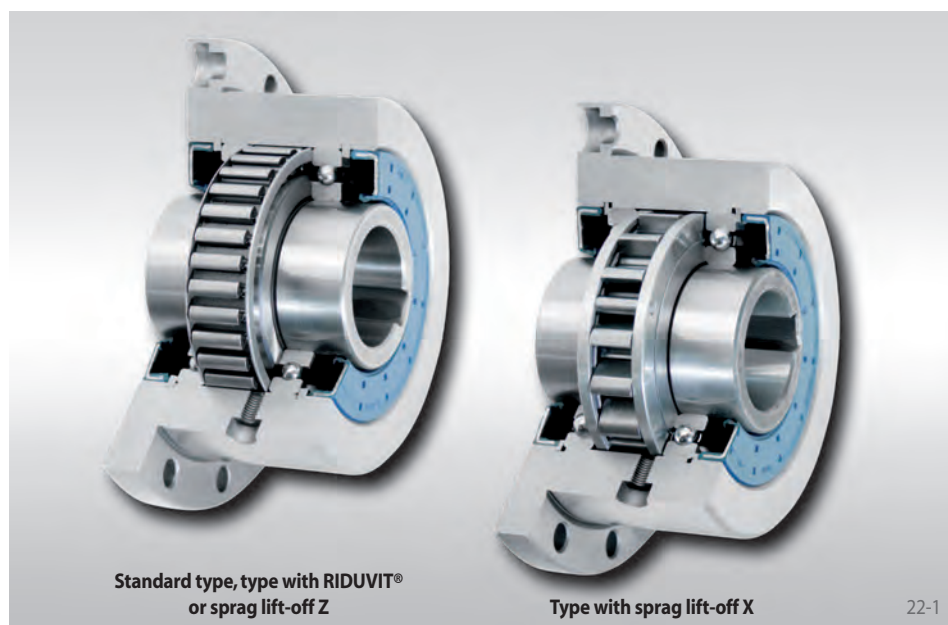

Application as

- ▶ Backstop
- ▶ Overrunning Clutch
- ▶ Indexing Freewheel

Features

Complete Freewheels FBF with mounting flange are sealed sprag freewheels with ball bearings. They are supplied oil-filled and ready for installation.

In addition to the standard type, three other types are available for extended service life.

Nominal torques up to 160 000 Nm.

Bores up to 300 mm. A multitude of standardized bore diameters are available with short delivery times.

Application example

Complete Freewheel FBF 72 DX as an overrunning clutch in the drive of a meat processing machine (chopper). During the mixing process, the gear motor drives the bowl via the gear wheel drive and simultaneously the knife shaft via the belt drive and the locked freewheel. In the cutting process, the knife shaft is driven by a second motor at high speed. By doing so, the inner ring overruns the outer ring that is driven by the gear motor and the gear motor is automatically disengaged. With the high speed of the inner ring in freewheeling operation, the type sprag lift-off X is used; the sprags work in freewheeling operation without contact and hence are wear-free.

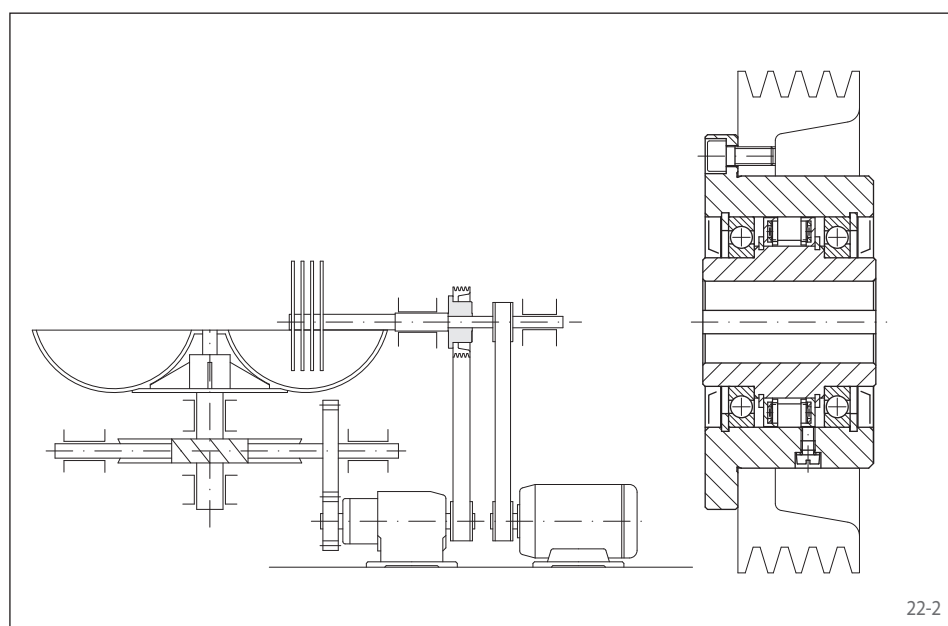

Mounting

The customer attachment part is centered on the external diameter D and then bolted on to the face via the flange.

The tolerance of the shaft must be ISO h6 or j6 and the tolerance of the pilot diameter D of the attachment part must be ISO H7 or J7.

Example for ordering

Freewheel size FBF 72, type with sprag lift-off X and 40 mm bore:

- FBF 72 DX, d = 40 mm

When ordering, please also specify the freewheeling direction of the inner ring when viewed in direction X:

- counterclockwise free or
- clockwise free

Complete Freewheels FBF

with mounting flange
with sprags, available in four types

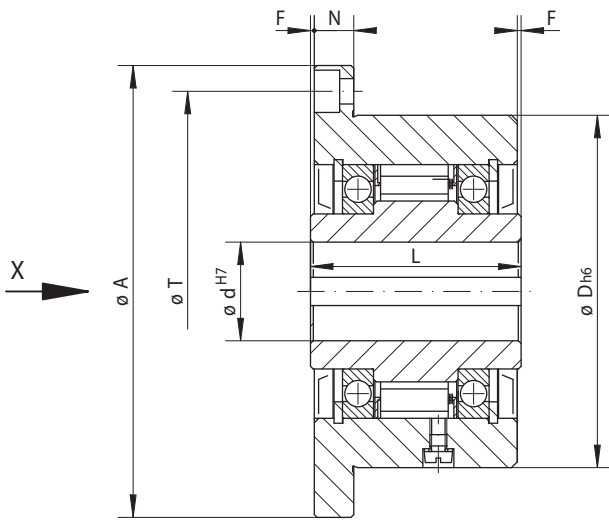

Size FBF 24 to FBF 270

23-1

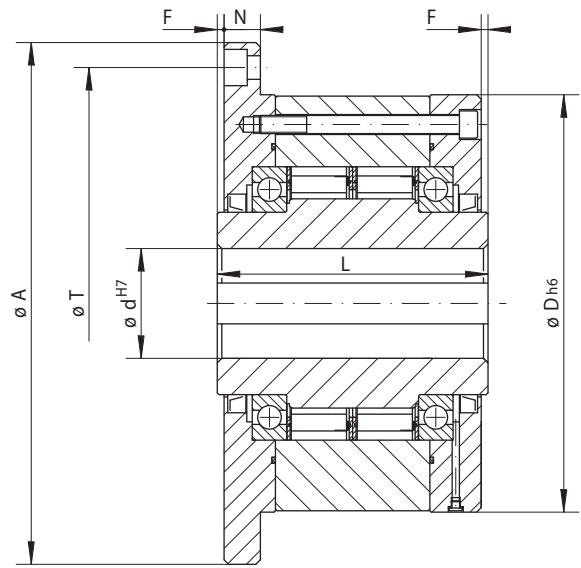

Size FBF 340 to FBF 440

23-2

Indexing Freewheel Overrunning Clutch Backstop	Standard type For universal use	Type with RIDUVIT® For extended service life using coated sprags	Type with sprag lift-off X For extended service life using sprag lift-off at high speed rotating inner ring	Type with sprag lift-off Z For extended service life using sprag lift-off at high speed rotating outer ring

Freewheel Size	Type	Nominal torque M _N Nm	Max. speed		Type	Nominal torque M _N Nm	Max. speed		Type	Nominal torque M _N Nm	Sprag lift-off at inner ring speed min ⁻¹	Max. speed		Type	Nominal torque M _N Nm	Sprag lift-off at outer ring speed min ⁻¹	Max. speed	
			Inner ring freewheels/ overruns min ⁻¹	Outer ring freewheels/ overruns min ⁻¹			Inner ring freewheels/ overruns min ⁻¹	Outer ring freewheels/ overruns min ⁻¹				Inner ring freewheels/ overruns min ⁻¹	Outer ring drives min ⁻¹				Outer ring freewheels/ overruns min ⁻¹	Inner ring drives min ⁻¹
FBF 24	CF	45	4800	5500	CFT	45	4800	5500										
FBF 29	CF	80	3500	4000	CFT	80	3500	4000										
FBF 37	SF	200	2500	2600	SFT	200	2500	2600										
FBF 44	SF	320	1900	2200	SFT	320	1900	2200	DX	130	860	1900	344	CZ	110	850	3000	340
FBF 57	SF	630	1400	1750	SFT	630	1400	1750	DX	460	750	1400	300	LZ	430	1400	2100	560
FBF 72	SF	1250	1120	1600	SFT	1250	1120	1600	DX	720	700	1150	280	LZ	760	1220	1800	488
FBF 82	SF	1800	1025	1450	SFT	1800	1025	1450	DX	1000	670	1050	268	SFZ	1700	1450	1600	580
FBF 107	SF	2500	880	1250	SFT	2500	880	1250	DX	1500	610	900	244	SFZ	2500	1300	1350	520
FBF 127	SF	5000	800	1150	SFT	5000	800	1150	SX	3400	380	800	152	SFZ	5000	1200	1200	480
FBF 140	SF	10000	750	1100	SFT	10000	750	1100	SX	7500	320	750	128	SFZ	10000	950	1150	380
FBF 200	SF	20000	630	900	SFT	20000	630	900	SX	23000	240	630	96	SFZ	20000	680	900	272
FBF 270	SF	40000	510	750	SFT	40000	510	750	UX	40000	210	510	84	SFZ	37500	600	750	240
FBF 340	SF	80000	460	630	SFT	80000	460	630										
FBF 440	SF	160000	400	550	SFT	160000	400	550										

The maximum transmissible torque is 2 times the specified nominal torque. See page 14 for determination of selection torque.

Freewheel Size	Bore d		A	D	F	G**	L	N	T	Z**	Weight
	Standard mm	max. mm									
FBF 24	12	14*	85	62	1,0	M 5	50	10	72	3	1,1
FBF 29	15	17*	92	68	1,0	M 5	52	11	78	3	1,3
FBF 37	20	22*	98	75	0,5	M 5	48	11	85	8	1,5
FBF 44	25*	25*	118	90	0,5	M 6	50	12	104	8	2,3
FBF 57	30	32*	128	100	0,5	M 6	65	12	114	12	3,2
FBF 72	40	42*	160	125	1,0	M 8	74	14	142	12	5,8
FBF 82	50*	50*	180	135	2,0	M 10	75	16	155	8	7,0
FBF 107	60	65*	214	170	2,5	M 10	90	18	192	10	12,6
FBF 127	70	75*	250	200	3,0	M 12	112	20	225	12	21,4
FBF 140	90	95*	315	250	5,0	M 16	150	22	280	12	46,0
FBF 200	120	120	370	300	5,0	M 16	160	25	335	16	68,0
FBF 270	140	150	490	400	6,0	M 20	212	32	450	16	163,0
FBF 340	180	240	615	500	7,5	M 24	265	40	560	18	300,0
FBF 440	220	300	775	630	7,5	M 30	315	50	710	18	564,0

Freewheels with bore diameters highlighted blue in the table are available with short delivery times.

Keyway according to DIN 6885, page 1 • Tolerance of keyway width JS10.

* Keyway according to DIN 6885, page 3 • Tolerance of keyway width JS10.

** Z = Number of fastening holes for screws G (DIN EN ISO 4762) on pitch circle T.

Complete Freewheels FGR ... R A1A2

with mounting flange
with rollers

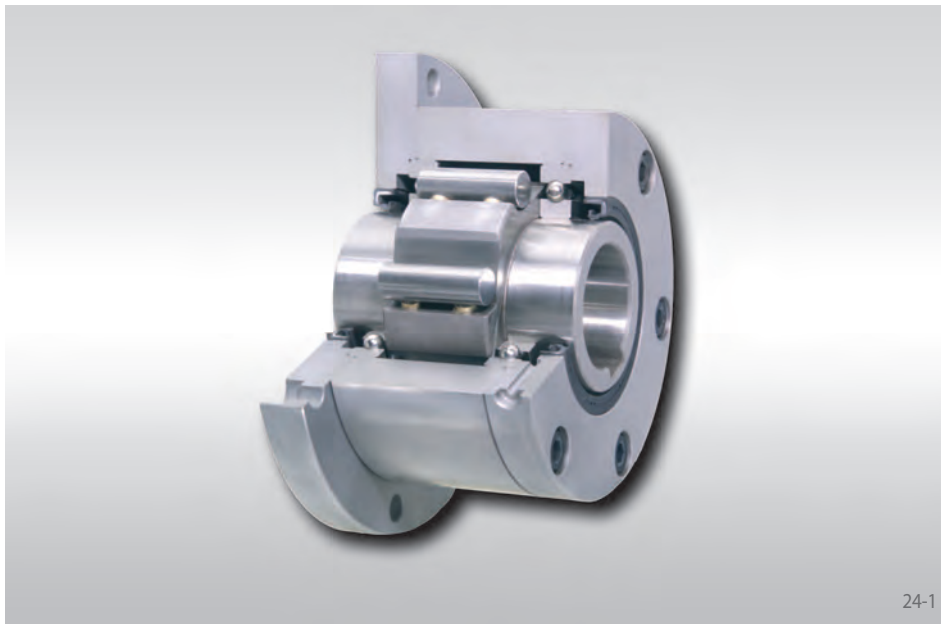

Application as

- ▶ Backstop
- ▶ Overrunning Clutch
- ▶ Indexing Freewheel

Features

Complete Freewheels FGR ... R A1A2 with mounting flange are sealed roller freewheels with ball bearings. They are oil lubricated.

Nominal torques up to 68 000 Nm.

Bores up to 150 mm.

Application example

Complete Freewheel FGR 50 R A1A2, used in a hydraulically released, spring actuated multi-disk brake for winch drives. When the load is lifted, the multiple-disk brake is closed and the inner ring is freewheeling. At a standstill, the freewheel functions as a backstop. The load is held by the brake and the locked freewheel. When lowering, the brake is released with control and the load is lowered via the locked freewheel. By using the freewheel, the hydraulic control could be designed in a simpler and more cost-effective manner.

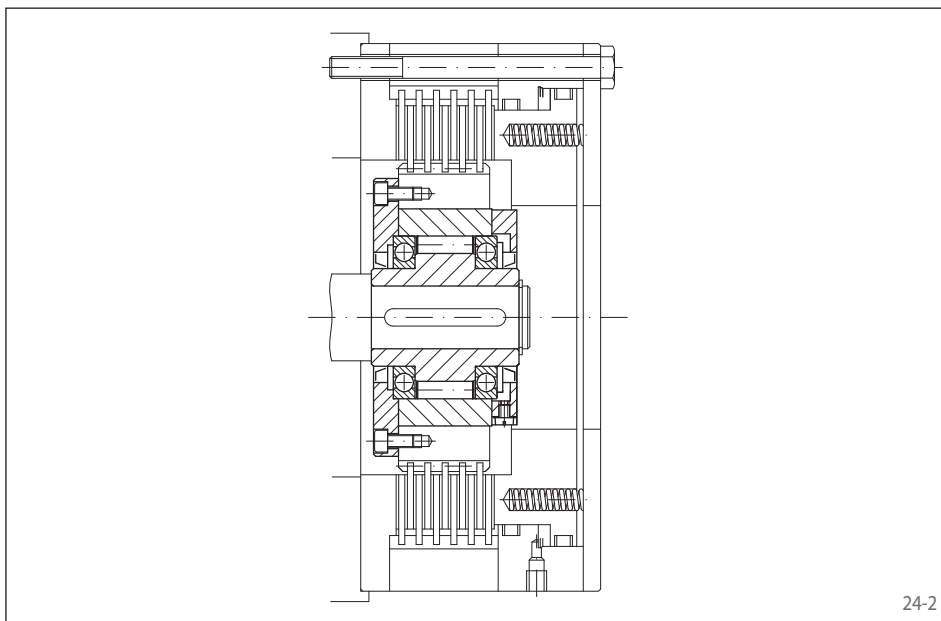

with mounting flange
with rollers

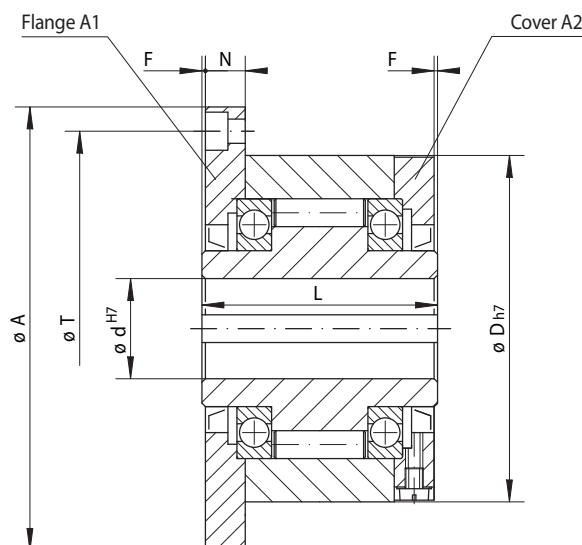

25-1

Indexing Freewheel Overrunning Clutch Backstop	Standard type For universal use	Dimensions

Freewheel Size	Type	Flange and cover combination	Nominal torque M_N Nm	Max. speed		Bore d mm	A mm	D mm	F mm	G**	L mm	N mm	T mm	Z**	Weight kg
				Inner ring freewheels/overruns min^{-1}	Outer ring freewheels/overruns min^{-1}										
FGR 12	R	A1A2	55	2 500	5 400	12	85	62	1	M 5	42	10,0	72	3	1,2
FGR 15	R	A1A2	130	2 200	4 800	15	92	68	1	M 5	52	11,0	78	3	1,6
FGR 20	R	A1A2	180	1 900	4 100	20	98	75	1	M 5	57	10,5	85	4	1,9
FGR 25	R	A1A2	290	1 550	3 350	25	118	90	1	M 6	60	11,5	104	4	2,9
FGR 30	R	A1A2	500	1 400	3 050	30	128	100	1	M 6	68	11,5	114	6	3,9
FGR 35	R	A1A2	730	1 300	2 850	35	140	110	1	M 6	74	13,5	124	6	4,9
FGR 40	R	A1A2	1 000	1 150	2 500	40	160	125	1	M 8	86	15,5	142	6	7,5
FGR 45	R	A1A2	1 150	1 100	2 400	45	165	130	1	M 8	86	15,5	146	8	7,8
FGR 50	R	A1A2	2 100	950	2 050	50	185	150	1	M 8	94	14,0	166	8	10,8
FGR 55	R	A1A2	2 600	900	1 900	55	204	160	1	M 10	104	18,0	182	8	14,0
FGR 60	R	A1A2	3 500	800	1 800	60	214	170	1	M 10	114	17,0	192	10	16,8
FGR 70	R	A1A2	6 000	700	1 600	70	234	190	1	M 10	134	18,5	212	10	20,8
FGR 80	R	A1A2	6 800	600	1 400	80	254	210	1	M 10	144	21,0	232	10	27,0
FGR 90	R	A1A2	11 000	500	1 300	90	278	230	1	M 12	158	20,5	254	10	40,0
FGR 100	R	A1A2	20 000	350	1 100	100	335	270	1	M 16	182	30,0	305	10	67,0
FGR 130	R	A1A2	31 000	250	900	130	380	310	1	M 16	212	29,0	345	12	94,0
FGR 150	R	A1A2	68 000	200	700	150	485	400	1	M 20	246	32,0	445	12	187,0

■ Freewheels with bore diameters highlighted blue in the table are available with short delivery times.

The maximum transmissible torque is 2 times the specified nominal torque. See page 14 for determination of selection torque.

Keyway according to DIN 6885, page 1 • Tolerance of keyway width JS10.

** Z = Number of fastening holes for screws G (DIN EN ISO 4762) on pitch circle T.

Mounting

Basic Freewheel, flange, cover, seals and screws are supplied loose. These must be assembled by the customer with regard to the required freewheeling direction into the Complete Freewheel. Prior to commissioning, the freewheel must be filled with oil of the specified quality. Upon request, assembled Complete Freewheels already oil-filled can be supplied.

The customer attachment part is centered on the external diameter D and bolted on via flange A1.

The tolerance of the shaft must be ISO h6 or j6 and the tolerance of the pilot diameter D of the attachment part must be ISO H7 or J7.

Example for ordering

Freewheel size FGR 25, standard type with flange A1 and cover A2:

- FGR 25 R A1A2

Basic Freewheel, flange, cover, seals and screws are supplied loose provided nothing else is stated in the order. If assembled, oil-filled, Complete Freewheels are to be supplied, this must be specified in the order. When ordering, please also specify the freewheeling direction of the inner ring when viewed in direction X:

- counterclockwise free or
- clockwise free

Complete Freewheels FGR ... R A2A7

with mounting flange
with rollers



26-1

Application as

- ▶ Backstop
- ▶ Overrunning Clutch
- ▶ Indexing Freewheel

Features

Complete Freewheels FGR ... R A2A7 with mounting flange are sealed roller freewheels with ball bearings. They are oil lubricated.

Nominal torques up to 68 000 Nm.

Bores up to 150 mm.

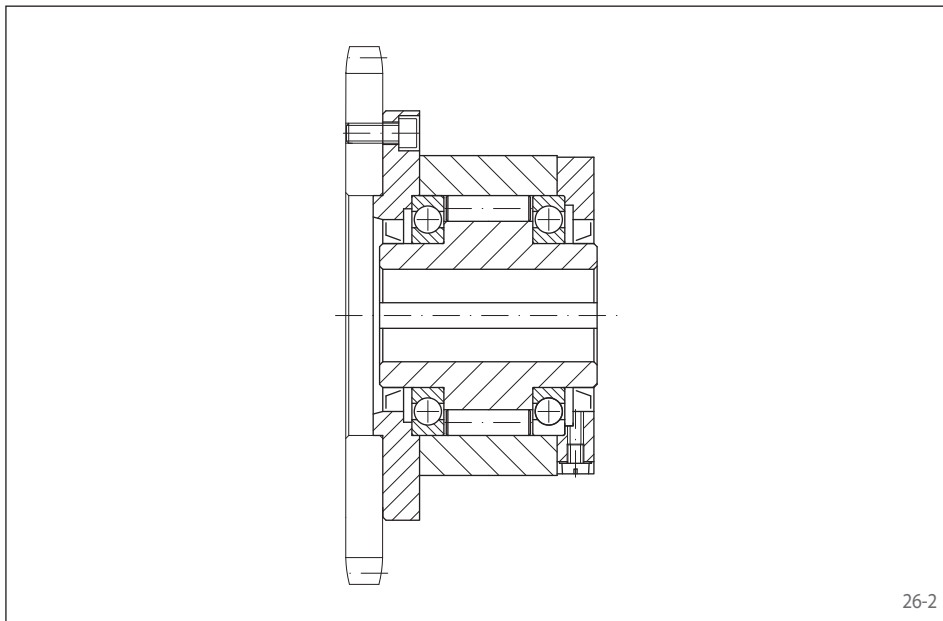

26-2

Application example

Complete Freewheels FGR 50 R A2A7 in a feed unit for sheet material. The drive is transmitted via the inner ring of the freewheel, which drives the feed rollers of the sprocket. Hence the sheet material is transported with the help of the freewheel. During the handover of the material into the next machine the material is able to overrun the drive unit.

with mounting flange
with rollers

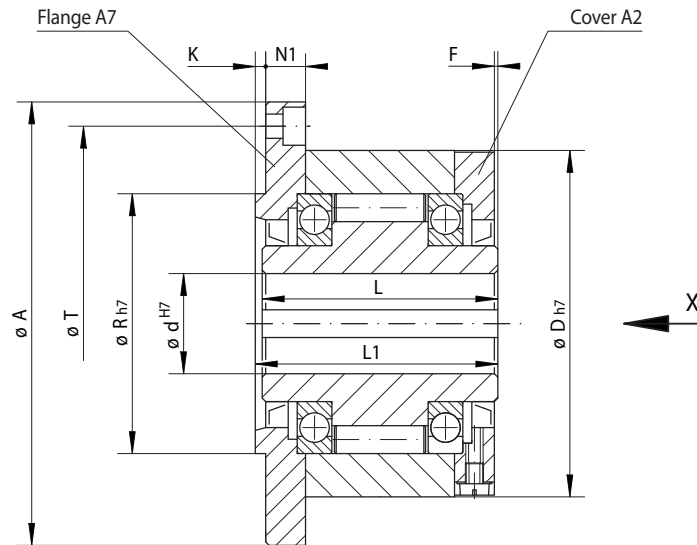

27-1

Indexing Freewheel Overrunning Clutch Backstop	Standard type For universal use	Dimensions

Freewheel Size	Type	Flange and cover combination	Nominal torque M_N Nm	Max. speed		Bore d mm	A mm	D mm	F mm	G**	K mm	L mm	L1 mm	N1 mm	R mm	T mm	Z**	Weight kg
				Inner ring freewheels/overruns min^{-1}	Outer ring freewheels/overruns min^{-1}													
FGR 12	R	A2A7	55	2 500	5 400	12	85	62	1	M 5	3,0	42	44	10,0	42	72	3	1,2
FGR 15	R	A2A7	130	2 200	4 800	15	92	68	1	M 5	3,0	52	54	11,0	47	78	3	1,6
FGR 20	R	A2A7	180	1 900	4 100	20	98	75	1	M 5	3,0	57	59	10,5	55	85	4	1,9
FGR 25	R	A2A7	290	1 550	3 350	25	118	90	1	M 6	3,0	60	62	11,5	68	104	4	2,9
FGR 30	R	A2A7	500	1 400	3 050	30	128	100	1	M 6	3,0	68	70	11,5	75	114	6	3,9
FGR 35	R	A2A7	730	1 300	2 850	35	140	110	1	M 6	3,5	74	76	13,0	80	124	6	4,9
FGR 40	R	A2A7	1 000	1 150	2 500	40	160	125	1	M 8	3,5	86	88	15,0	90	142	6	7,5
FGR 45	R	A2A7	1 150	1 100	2 400	45	165	130	1	M 8	3,5	86	88	15,0	95	146	8	7,8
FGR 50	R	A2A7	2 100	950	2 050	50	185	150	1	M 8	4,0	94	96	13,0	110	166	8	10,8
FGR 55	R	A2A7	2 600	900	1 900	55	204	160	1	M 10	4,0	104	106	17,0	115	182	8	14,0
FGR 60	R	A2A7	3 500	800	1 800	60	214	170	1	M 10	4,0	114	116	16,0	125	192	10	16,8
FGR 70	R	A2A7	6 000	700	1 600	70	234	190	1	M 10	4,0	134	136	17,5	140	212	10	20,8
FGR 80	R	A2A7	6 800	600	1 400	80	254	210	1	M 10	4,0	144	146	20,0	160	232	10	27,0
FGR 90	R	A2A7	11 000	500	1 300	90	278	230	1	M 12	4,5	158	160	19,0	180	254	10	40,0
FGR 100	R	A2A7	20 000	350	1 100	100	335	270	1	M 16	5,0	182	184	28,0	210	305	10	67,0
FGR 130	R	A2A7	31 000	250	900	130	380	310	1	M 16	5,0	212	214	27,0	240	345	12	94,0
FGR 150	R	A2A7	68 000	200	700	150	485	400	1	M 20	5,0	246	248	30,0	310	445	12	187,0

■ Freewheels with bore diameters highlighted blue in the table are available with short delivery times.
The maximum transmissible torque is 2 times the specified nominal torque. See page 14 for determination of selection torque.
Keyway according to DIN 6885, page 1 • Tolerance of keyway width JS10.
** Z = Number of fastening holes for screws G (DIN EN ISO 4762) on pitch circle T.

Mounting

Basic Freewheel, flange, cover, seals and screws are supplied loose. These must be assembled by the customer with regard to the required freewheeling direction into the Complete Freewheel. Prior to commissioning, the freewheel must be filled with oil of the specified quality. Upon request, assembled Complete Freewheels already oil-filled can be supplied.

The customer attachment part is centered on the pilot diameter R and bolted on to the face via flange A7. Hence, Complete Freewheels FGR ... R A2A7 are particularly suitable for attaching smaller and narrower parts (sprockets, gear wheels etc.).

The tolerance of the shaft must be ISO h6 or j6 and the tolerance of the pilot diameter R of the attachment part must be ISO H7 or J7.

Example for ordering

Freewheel size FGR 25, standard type with cover A2 and flange A7:

- FGR 25 R A2A7

Basic Freewheel, flange, cover, seals and screws are supplied loose provided nothing else is stated in the order.

If assembled, oil-filled, Complete Freewheels are to be supplied, this must be specified in the order. When ordering, please also specify the freewheeling direction of the inner ring when viewed in direction X:

- counterclockwise free or
- clockwise free

Complete Freewheels BM

for keyway connection on the outer ring
with rollers or with sprag lift-off X

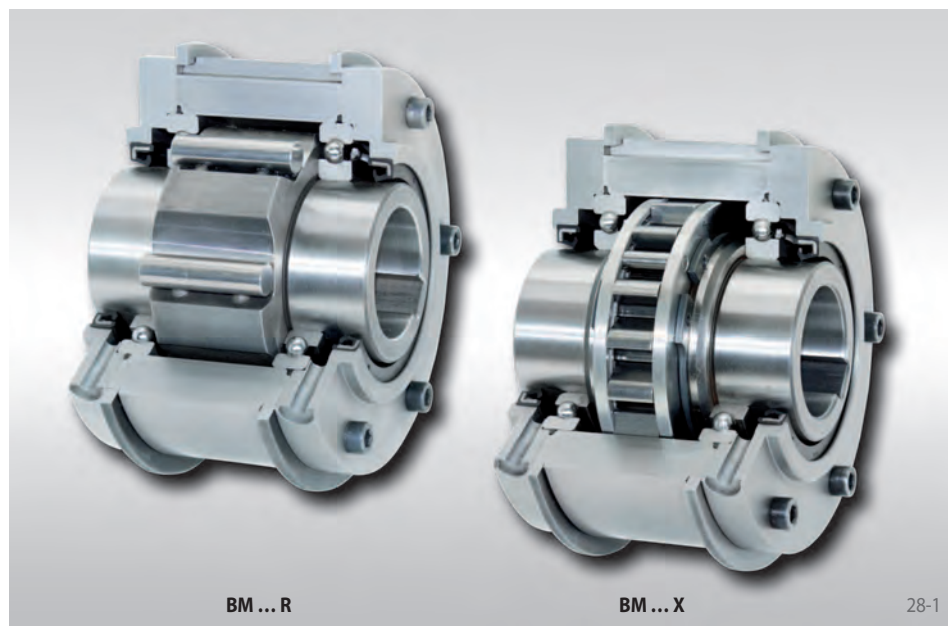

Application as

- ▶ Backstop
- ▶ Overrunning Clutch
- ▶ Indexing Freewheel

Features

Complete Freewheels BM are sealed freewheels with ball bearings. They are supplied oil-filled and ready for installation.

Besides the standard type, the type with sprag lift-off X is available for wearfree freewheeling operation at high speed rotating inner ring.

Nominal torques up to 57 500 Nm.

Bores up to 150 mm. A multitude of standardized bore diameters are available with short delivery times.

Application example

Complete Freewheel BM 60 SX as a backstop, arranged at the end of the intermediate shaft of a spur gearbox. The freewheel is used without the radial seal rings on each side, and is lubricated by the gearbox oil. A radial holding pin engages in the keyway of the outer ring. The backdriving torque is supported by the holding pin in the stationary housing. By removing the radial holding pin, the installation can be turned in both directions in order to carry out maintenance work. With the high shaft speed in normal operation (freewheeling operation), the type with sprag lift-off X is used; the sprags work in freewheeling operation without contact and hence are wear-free.

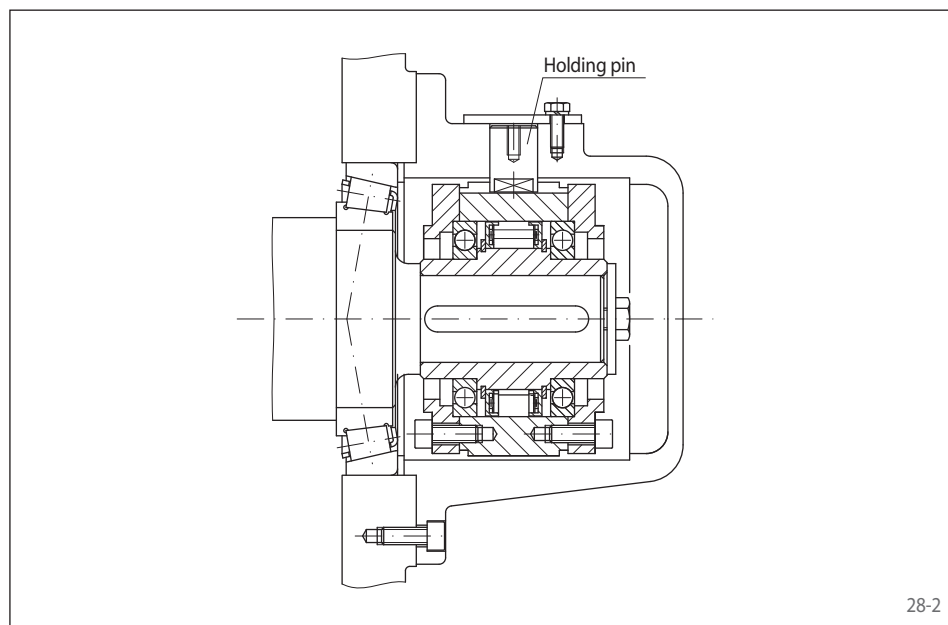

Complete Freewheels BM

for keyway connection on the outer ring
with rollers or with sprag lift-off X

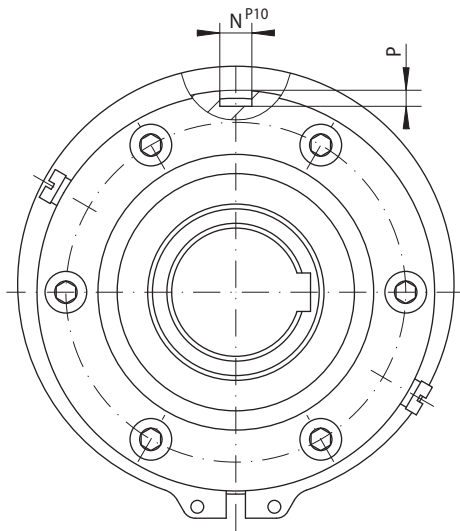

29-1

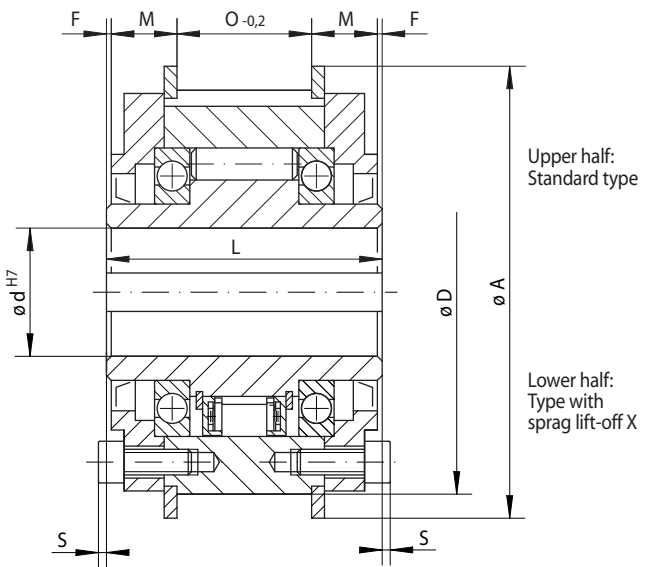

29-2

Indexing Freewheel	Standard type For universal use	Type with sprag lift-off X For extended service life using sprags lift-off at high speed rotating inner ring	Dimensions
Overrunning Clutch			
Backstop			

Freewheel Size	Type	Nominal torque M_N Nm	Max. speed		Type	Nominal torque M_N Nm	Sprag lift-off at inner ring speed min^{-1}	Max. speed		Bore d		A mm	D mm	F mm	L mm	M mm	N mm	O mm	P mm	S mm	Weight kg
			Inner ring freewheels/overruns min^{-1}	Outer ring freewheels/overruns min^{-1}				Inner ring freewheels/overruns min^{-1}	Outer ring drives min^{-1}	Standard mm	max. mm										
BM 12	R	150	1 750	3 500						15	15	84	70	0,75	68	15,75	5	35	3,0	3,0	1,5
BM 15	R	230	1 650	3 300						20	20	94	80	0,75	70	15,75	5	37	3,0	3,0	2,0
BM 18	R	340	1 550	3 100						25	25	111	95	0,75	70	16,25	8	36	4,0	3,0	2,9
BM 20	R	420	1 450	2 900	DX	420	750	1 700	300	30	30	121	105	0,75	77	20,25	8	35	4,0	2,5	3,8
BM 25	R	800	1 250	2 500	DX	700	700	1 600	280	40	40	144	125	0,75	93	22,25	10	47	5,0	2,5	6,6
BM 28	R	1 200	1 100	2 200						45	45	155	135	0,75	95	23,25	12	47	5,0	4,0	7,8
BM 30	R	1 600	1 000	2 000	DX	1 250	630	1 600	252	50	50	171	150	0,75	102	24,25	12	52	5,0	4,0	10,3
BM 35	R	1 800	900	1 800						55	55	182	160	0,75	110	24,25	14	60	5,5	4,0	12,5
BM 40	R	3 500	800	1 600	SX	1 900	430	1 500	172	60	60	202	180	0,75	116	25,25	16	64	6,0	6,5	17,4
BM 45	R	7 100	750	1 500	SX	2 300	400	1 500	160	70	70	218	195	1,25	130	24,75	20	78	7,5	8,5	22,4
BM 50	R	7 500	700	1 400						75	75	227	205	1,25	132	26,75	20	76	7,5	8,5	24,2
BM 52	R	9 300	650	1 300	SX	5 600	320	1 500	128	80	80	237	215	1,75	150	33,75	25	79	9,0	8,5	31,1
BM 55	R	12 500	550	1 100	SX	7 700	320	1 250	128	90	90	267	245	1,75	170	35,25	25	96	9,0	6,5	45,6
BM 60	R	14 500	500	1 000	SX	14 500	250	1 100	100	100	105	314	290	1,75	206	40,25	28	122	10,0	6,5	78,2
BM 70	R	22 500	425	850	SX	21 000	240	1 000	96	120	120	350	320	1,25	215	44,75	28	123	10,0	9,0	93,4
BM 80	R	25 000	375	750						130	130	380	350	1,75	224	46,25	32	128	11,0	8,5	116,8
BM 90	R	33 500	350	700						140	140	400	370	2,75	236	49,25	32	132	11,0	7,5	136,7
BM 95	R	35 000	300	600						150	150	420	390	2,75	249	53,25	36	137	12,0	6,5	159,3
BM 100	R	57 500	250	500	UX	42 500	210	750	84	150	150	450	410	3,75	276	56,25	36	156	12,0	11,5	198,4

■ Freewheels with bore diameters highlighted blue in the table are available with short delivery times.
The maximum transmissible torque is 2 times the specified nominal torque. See page 14 for determination of selection torque.
Keyway according to DIN 6885, page 1 • Tolerance of keyway width JS10.

Mounting

The customer attachment part is connected via a keyway connection with the outer ring. The customer must provide the key required for assembling the attachment part.

The tolerance of the shaft must be ISO h6 or j6 and the tolerance of the pilot diameter D of the attachment part must be ISO H7 or J7.

Example for ordering

Freewheel size BM 20, standard type and 30 mm bore:

- BM 20 R, d = 30 mm

Complete Freewheels FGRN ... R A5A6

for keyway connection on the outer ring
with rollers



Application as

- ▶ Backstop
- ▶ Overrunning Clutch
- ▶ Indexing Freewheel

Features

Complete Freewheels FGRN ... R A5A6 are sealed roller freewheels with ball bearings. They are oil lubricated.

Nominal torques up to 6 800 Nm.

Bores up to 80 mm.

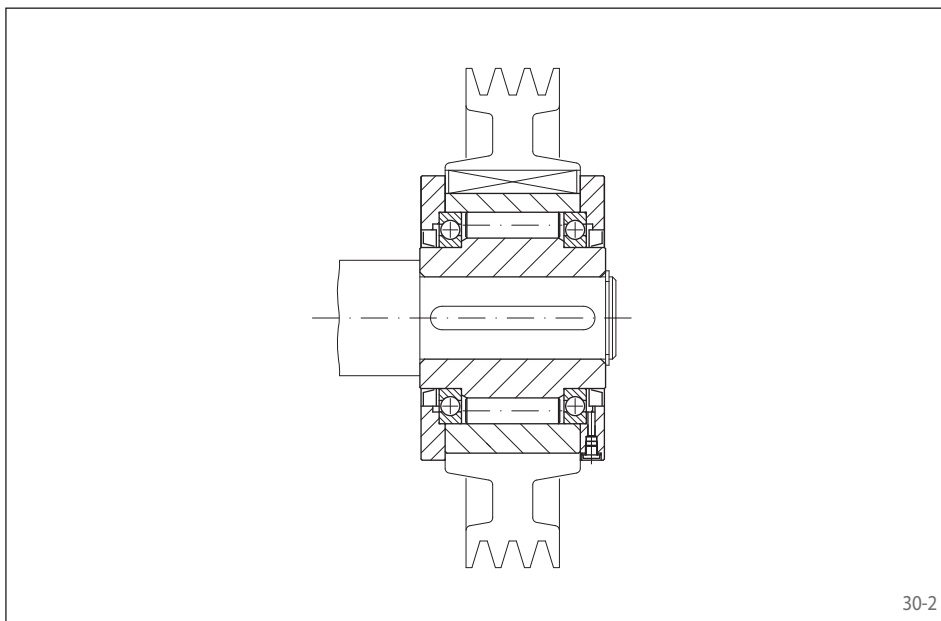

Application example

Complete Freewheel FGRN 45 R as an overrunning clutch on the shaft end of a mobile fan. In normal operation, the fan is driven by a diesel motor via the V-belt drive. By doing so, the freewheel works in driving operation. When the motor is turned off, the freewheel automatically disengages the rotating flywheel mass of the fan from the drive. In this operating state, the inner ring overruns the stationary outer ring; the freewheel works in freewheeling operation.

for keyway connection on the outer ring
with rollers

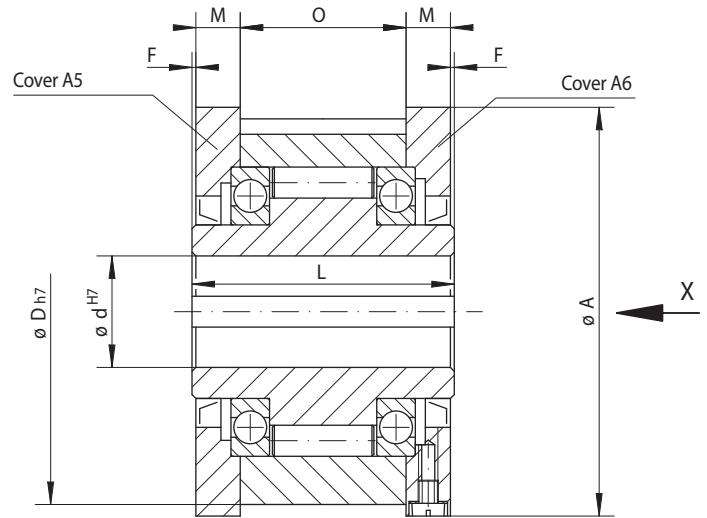
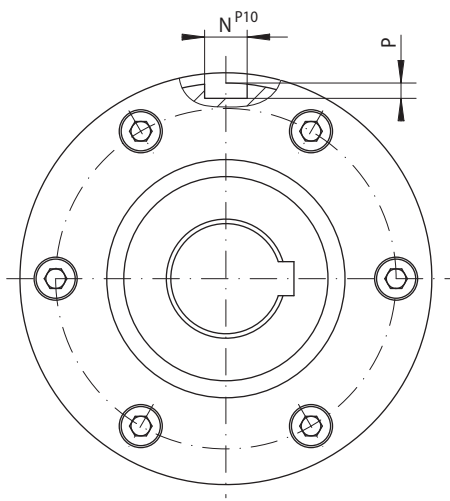

31-1

31-2

Indexing Freewheel Overrunning Clutch Backstop	Standard type For universal use	Dimensions
	<div style="background-color: #e0f0ff; width: 100%; height: 10px;"></div> <div style="background-color: #e0ffe0; width: 100%; height: 10px;"></div> <div style="background-color: #ffe0e0; width: 100%; height: 10px;"></div>	

Freewheel Size	Type	Cover combination	Nominal Torque M_N Nm	Max. speed		Bore d mm	A mm	D mm	F mm	L mm	M mm	N mm	P mm	O mm	Weight kg
				Inner ring freewheels/overruns min^{-1}	Outer ring freewheels/overruns min^{-1}										
FGRN 12	R	A5A6	55	2 500	5 400	12	70	62	1	42	10,0	4	2,5	20	1,2
FGRN 15	R	A5A6	130	2 200	4 800	15	76	68	1	52	11,0	5	3,0	28	1,6
FGRN 20	R	A5A6	180	1 900	4 100	20	84	75	1	57	10,5	6	3,5	34	1,9
FGRN 25	R	A5A6	290	1 550	3 350	25	99	90	1	60	11,5	8	4,0	35	2,9
FGRN 30	R	A5A6	500	1 400	3 050	30	109	100	1	68	11,5	8	4,0	43	3,9
FGRN 35	R	A5A6	730	1 300	2 850	35	119	110	1	74	13,5	10	5,0	45	4,9
FGRN 40	R	A5A6	1 000	1 150	2 500	40	135	125	1	86	15,5	12	5,0	53	7,5
FGRN 45	R	A5A6	1 150	1 100	2 400	45	140	130	1	86	15,5	14	5,5	53	7,8
FGRN 50	R	A5A6	2 100	950	2 050	50	160	150	1	94	14,0	14	5,5	64	10,8
FGRN 55	R	A5A6	2 600	900	1 900	55	170	160	1	104	18,0	16	6,0	66	14,0
FGRN 60	R	A5A6	3 500	800	1 800	60	182	170	1	114	17,0	18	7,0	78	16,8
FGRN 70	R	A5A6	6 000	700	1 600	70	202	190	1	134	18,5	20	7,5	95	20,8
FGRN 80	R	A5A6	6 800	600	1 400	80	222	210	1	144	21,0	22	9,0	100	27,0

■ Freewheels with bore diameters highlighted blue in the table are available with short delivery times.
The maximum transmissible torque is 2 times the specified nominal torque. See page 14 for determination of selection torque.
Keyway according to DIN 6885, page 1 • Tolerance of keyway width JS10.

Mounting

Basic Freewheel, covers, seals and screws are supplied loose. These must be assembled by the customer with regard to the required freewheeling direction into the Complete Freewheel. Prior to commissioning, the freewheel must be filled with oil of the specified quality. Upon request, assembled Complete Freewheels already oil-filled can be supplied.

The customer attachment part is connected via a keyway connection with the outer ring. The customer must provide the key required for assembling the attachment part.

The tolerance of the shaft must be ISO h6 or j6 and the tolerance of the pilot diameter D of the attachment part must be ISO H7 or J7.

Example for ordering

Freewheel size FGRN 60, standard type with flange A5 and cover A6:

- FGRN 60 R A5A6

Basic Freewheel, covers, seals and screws are supplied loose provided nothing else is stated in the order.

If assembled, oil-filled, Complete Freewheels are to be supplied, this must be specified in the order. When ordering, please also specify the freewheeling direction of the inner ring when viewed in direction X:

- counterclockwise free or
- clockwise free

Complete Freewheels BA

with lever arm

with rollers or with sprag lift-off X

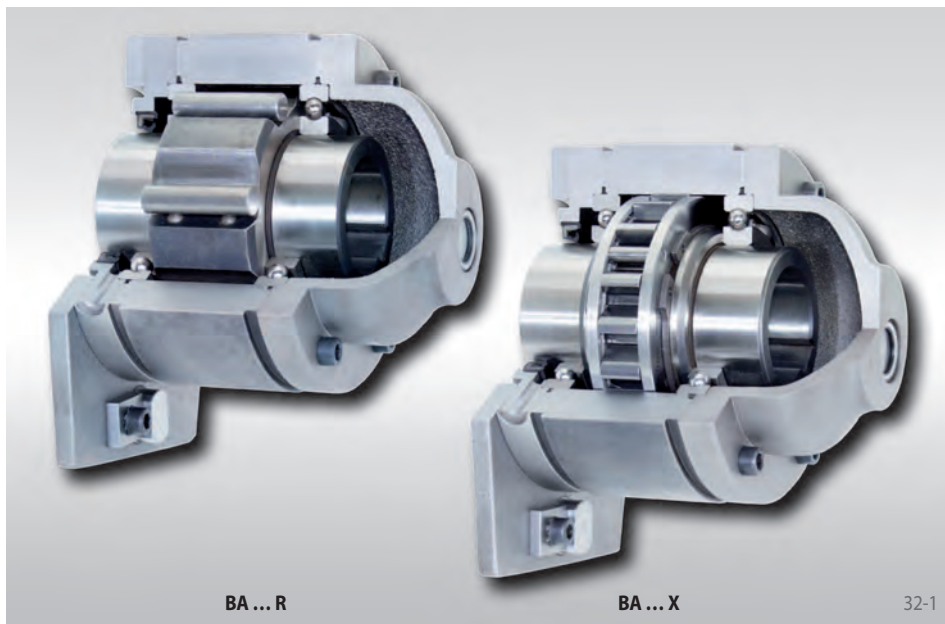

Application as

▶ Backstop

Features

Complete Freewheels BA with lever arm are sealed freewheels with ball bearings.

The freewheels BA have an end cover and are fitted to shaft ends. The oil filling is carried out after the freewheel has been fitted to the end of the shaft.

Besides the standard type, the type with sprag lift-off X is available for wearfree freewheeling operation at high speed rotating inner ring.

Nominal torques up to 57 500 Nm.

Bores up to 150 mm. A multitude of standardized bore diameters are available with short delivery times.

Application example

Complete Freewheel BA 45 SX as a backstop, arranged at the end of the intermediate shaft of a spur gearbox. The backdriving torque is supported by the lever arm with holding pin on the gearbox housing. If the holding pin is removed, the shaft can be turned in both directions. With the high shaft speed in normal operation (freewheeling operation), the type with sprag lift-off X is used; the sprags work in freewheeling operation without contact and hence are wear-free.

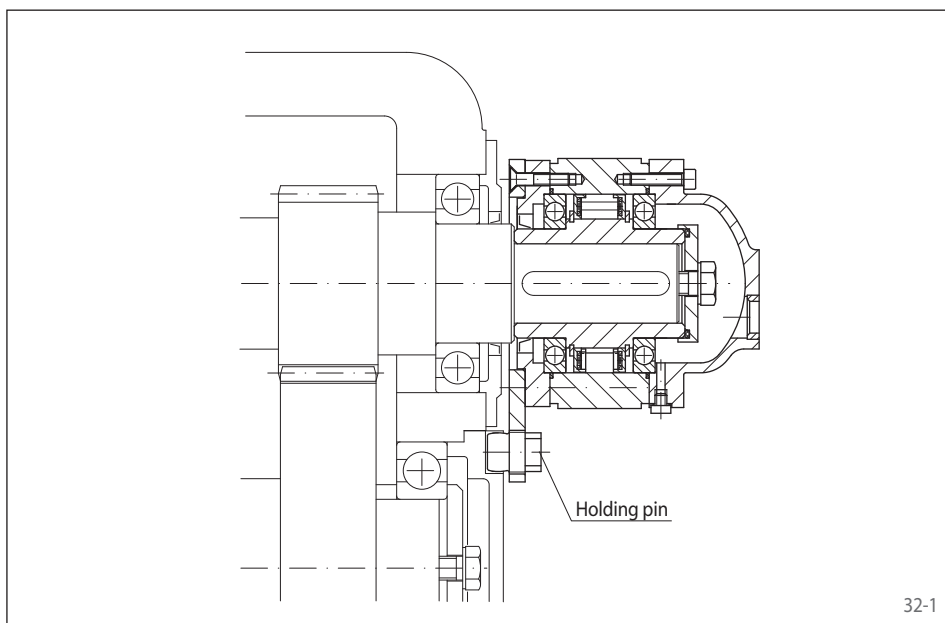

Complete Freewheels BA

with lever arm
with rollers or with sprag lift-off X

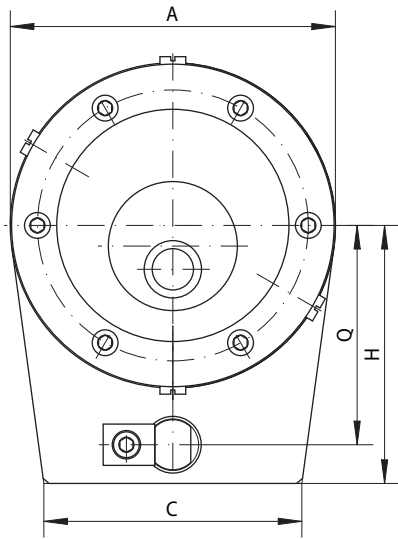

33-1

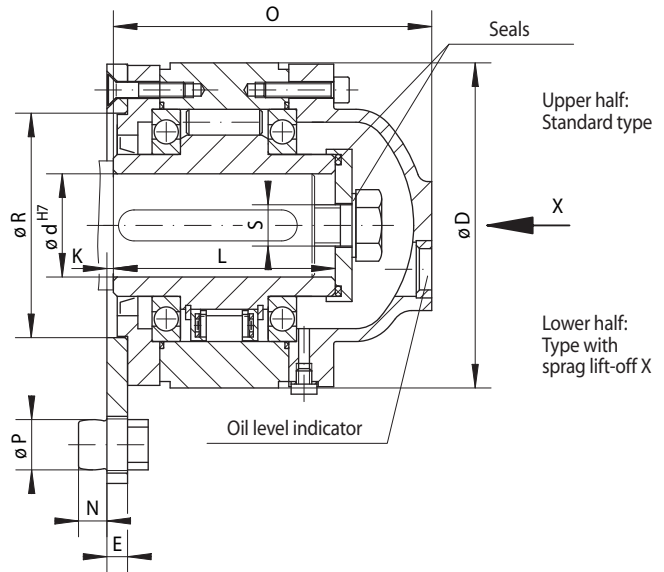

Complete Freewheels

33-2

Backstop	Standard type For universal use	Type with sprag lift-off X For extended service life using sprag lift-off at high speed rotating inner ring	Dimensions																		

Freewheel Size	Type	Nominal Torque M_N Nm	Max. speed Inner ring freewheels min^{-1}	Type	Nominal Torque M_N Nm	Sprag lift-off at inner ring speed min^{-1}	Max. speed Inner ring freewheels min^{-1}	Bore d		A	C	D	E	H	K	L	N	O	P	Q	R	S for Screw	Weight kg
								Standard mm	max. mm														
BA 12	R	150	1 750					15	15	71	50	71	8	53	4,5	68	9	91	11,5	42	45	M 6	2
BA 15	R	230	1 650					20	20	81	60	81	8	62	4,5	70	9	93	13,5	50	50	M 6	3
BA 18	R	340	1 550					25	25	96	70	96	8	73	4,5	70	9	96	15,5	60	60	M 10	4
BA 20	R	420	1 450	DX	400	750	1 700	30	30	110	90	106	8	80	2,5	77	11	104	19,5	65	70	M 10	5
BA 25	R	800	1 250	DX	650	700	1 600	40	40	126	100	126	8	90	2,5	93	11	125	19,5	75	80	M 12	8
BA 28	R	1 200	1 100					45	45	140	110	136	10	105	3,5	95	14	129	24,5	85	90	M 12	9
BA 30	R	1 600	1 000	DX	1 100	630	1 600	50	50	155	120	151	10	120	3,5	102	16	140	27,5	95	100	M 16	12
BA 35	R	1 800	900					55	55	170	130	161	10	140	3,5	110	19	151	33,5	112	110	M 16	15
BA 40	R	3 500	800	SX	1 400	430	1 500	60	60	190	150	181	12	160	5,5	116	22	160	37,5	130	120	M 16	20
BA 45	R	7 100	750	SX	2 300	400	1 500	70	70	210	160	196	14	175	7,0	130	26	176	41,5	140	130	M 16	25
BA 50	R	7 500	700					75	75	220	180	206	14	185	7,0	132	26	178	41,5	150	140	M 16	30
BA 52	R	9 300	650	SX	4 900	320	1 500	80	80	230	190	216	14	200	4,5	150	26	208	41,5	160	150	M 20	35
BA 55	R	12 500	550	SX	6 500	320	1 250	90	90	255	200	246	15	210	3,5	170	29	228	49,5	170	160	M 20	50
BA 60	R	14 500	500	SX	14 500	250	1 100	100	105	295	220	291	20	250	8,5	206	35	273	60,0	200	190	M 24	91
BA 70	R	22 500	425	SX	21 000	240	1 000	120	120	335	260	321	25	280	14,0	215	39	291	65,0	225	210	M 24	115
BA 80	R	25 000	375					130	130	360	280	351	30	280	18,5	224	39	302	65,0	225	220	M 24	150
BA 90	R	33 500	350					140	140	385	300	371	35	310	22,5	236	55	314	70,0	250	240	M 30	180
BA 95	R	35 000	300					150	150	400	350	391	40	310	27,5	249	55	337	70,0	250	250	M 30	225
BA 100	R	57 500	250	UX	42 500	210	750	150	150	420	380	411	45	345	31,5	276	60	372	80,0	280	270	M 30	260

Freewheels with bore diameters highlighted blue in the table are available with short delivery times.
The maximum transmissible torque is 2 times the specified nominal torque. See page 14 for determination of selection torque.
Keyway according to DIN 6885, page 1 • Tolerance of keyway width JS10.

Mounting

The backdriving torque is supported by the lever arm with holding pin. The holding pin engages in a slot or bore in the frame of the machine. It must have 0,5 to 2 mm play in the axial and radial directions.

If the holding pin is removed, the shaft can be turned in both directions.

The tolerance of the shaft must be ISO h6 or j6. For freewheels BA, the inner ring must be secured axially with the supplied retainer plate. Prior to commissioning, the freewheel must be filled with oil of the specified quality.

Example for ordering

Freewheel size BA 30, type with sprag lift-off X and 50 mm bore:

- BA 30 DX, d = 50 mm

When ordering, please also specify the freewheeling direction of the inner ring when viewed in direction X:

- counterclockwise free or
- clockwise free

Complete Freewheels BC

with lever arm

with rollers or with sprag lift-off X

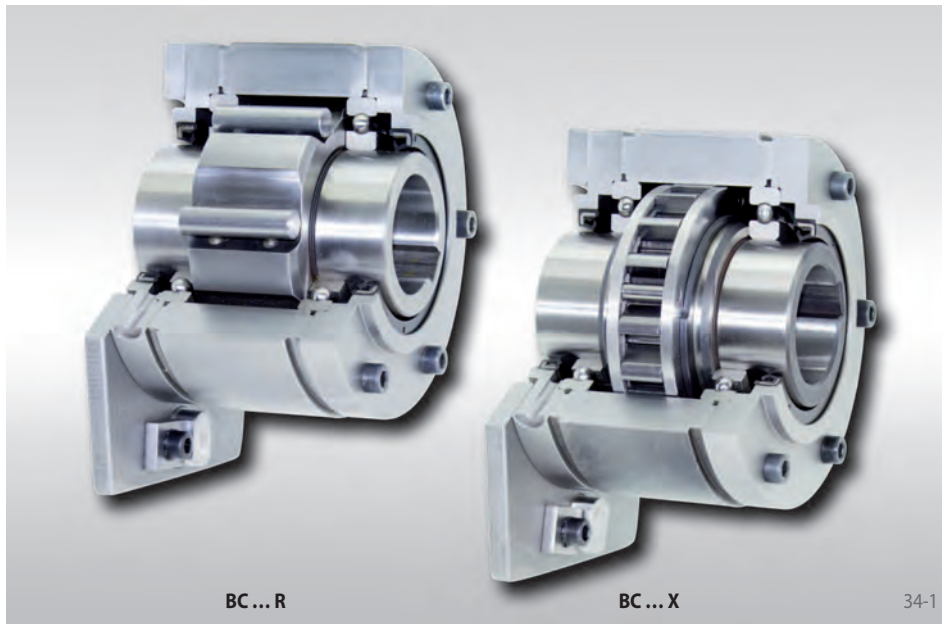

Application as

▶ Backstop

Features

Complete Freewheels BC with lever arm are sealed freewheels with ball bearings.

Freewheels BC are supplied oil-filled and ready for installation. They are arranged on through shafts or shaft ends.

Besides the standard type, the type with sprag lift-off X is available for wearfree freewheeling operation at high speed rotating inner ring.

Nominal torques up to 57 500 Nm.

Bores up to 150 mm. A multitude of standardized bore diameters are available with short delivery times.

Application example

Complete Freewheel BC 90 R as a backstop on the end of a transport roller. The backdriving torque is supported by the lever arm with holding pin on the base. If the holding pin is removed, the shaft can be turned in both directions.

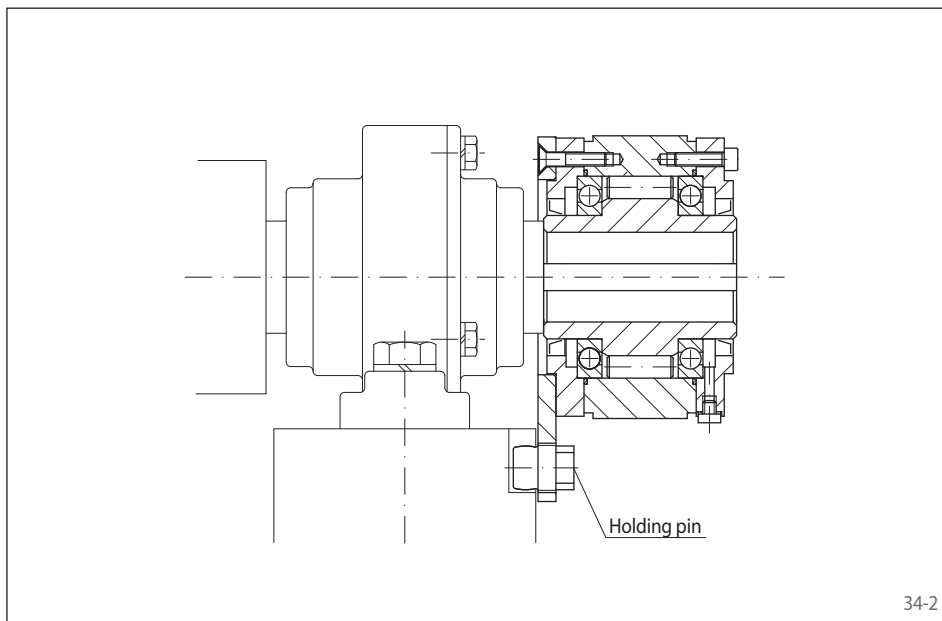

with lever arm

with rollers or with sprag lift-off X

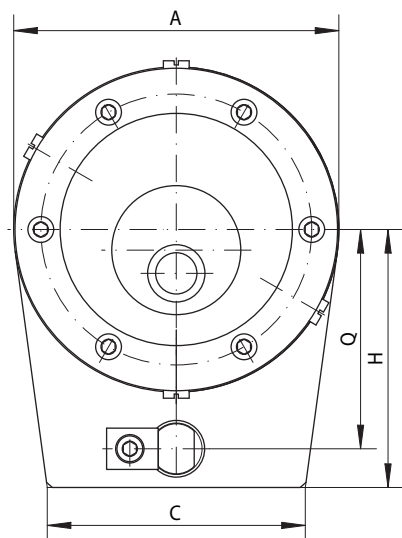

35-1

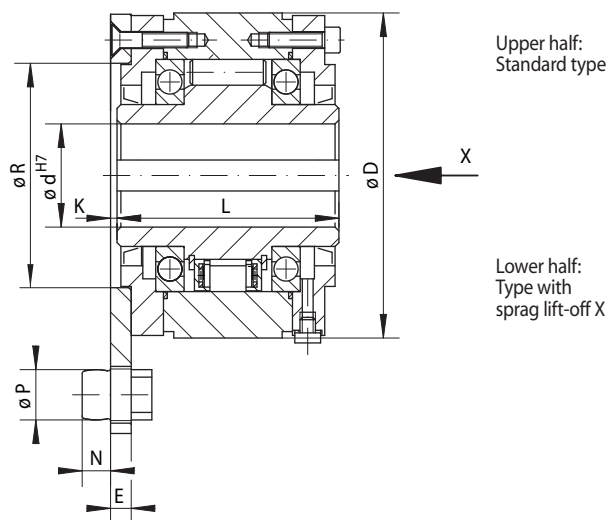

35-2

Backstop	Standard type	Type with sprag lift-off X	Dimensions																			
	For universal use	For extended service life using sprag lift-off at high speed rotating inner ring																				

Freewheel Size	Type	Nominal Torque M_N Nm	Max. speed Inner ring freewheels min^{-1}	Type	Nominal Torque M_N Nm	Sprag lift-off at inner ring speed min^{-1}	Max. speed Inner ring freewheels min^{-1}	Bore d		A	C	D	E	H	K	L	N	O	P	Q	R	S for Screw	Weight kg
								Standard mm	max. mm														
BC 12	R	150	1 750					15	15	71	50	71	8	53	4,5	68	9	91	11,5	42	45	M 6	2
BC 15	R	230	1 650					20	20	81	60	81	8	62	4,5	70	9	93	13,5	50	50	M 6	3
BC 18	R	340	1 550					25	25	96	70	96	8	73	4,5	70	9	96	15,5	60	60	M 10	4
BC 20	R	420	1 450	DX	400	750	1 700	30	30	110	90	106	8	80	2,5	77	11	104	19,5	65	70	M 10	5
BC 25	R	800	1 250	DX	650	700	1 600	40	40	126	100	126	8	90	2,5	93	11	125	19,5	75	80	M 12	8
BC 28	R	1 200	1 100					45	45	140	110	136	10	105	3,5	95	14	129	24,5	85	90	M 12	9
BC 30	R	1 600	1 000	DX	1 100	630	1 600	50	50	155	120	151	10	120	3,5	102	16	140	27,5	95	100	M 16	12
BC 35	R	1 800	900					55	55	170	130	161	10	140	3,5	110	19	151	33,5	112	110	M 16	15
BC 40	R	3 500	800	SX	1 400	430	1 500	60	60	190	150	181	12	160	5,5	116	22	160	37,5	130	120	M 16	20
BC 45	R	7 100	750	SX	2 300	400	1 500	70	70	210	160	196	14	175	7,0	130	26	176	41,5	140	130	M 16	25
BC 50	R	7 500	700					75	75	220	180	206	14	185	7,0	132	26	178	41,5	150	140	M 16	30
BC 52	R	9 300	650	SX	4 900	320	1 500	80	80	230	190	216	14	200	4,5	150	26	208	41,5	160	150	M 20	35
BC 55	R	12 500	550	SX	6 500	320	1 250	90	90	255	200	246	15	210	3,5	170	29	228	49,5	170	160	M 20	50
BC 60	R	14 500	500	SX	14 500	250	1 100	100	105	295	220	291	20	250	8,5	206	35	273	60,0	200	190	M 24	91
BC 70	R	22 500	425	SX	21 000	240	1 000	120	120	335	260	321	25	280	14,0	215	39	291	65,0	225	210	M 24	115
BC 80	R	25 000	375					130	130	360	280	351	30	280	18,5	224	39	302	65,0	225	220	M 24	150
BC 90	R	33 500	350					140	140	385	300	371	35	310	22,5	236	55	314	70,0	250	240	M 30	180
BC 95	R	35 000	300					150	150	400	350	391	40	310	27,5	249	55	337	70,0	250	250	M 30	225
BC 100	R	57 500	250	UX	42 500	210	750	150	150	420	380	411	45	345	31,5	276	60	372	80,0	280	270	M 30	260

Freewheels with bore diameters highlighted blue in the table are available with short delivery times.
 The maximum transmissible torque is 2 times the specified nominal torque. See page 14 for determination of selection torque.
 Keyway according to DIN 6885, page 1 • Tolerance of keyway width JS10.

Mounting

The backdriving torque is supported by the lever arm with holding pin. The holding pin engages in a slot or bore in the frame of the machine. It must have 0,5 to 2 mm play in the axial and radial directions.

If the holding pin is removed, the shaft can be turned in both directions.

The tolerance of the shaft must be ISO h6 or j6. The freewheels BC are supplied oil-filled and ready for installation.

Example for ordering

Freewheel size BC 30, standard type and 50 mm bore:

- BC 30 R, d = 50 mm

When ordering, please also specify the freewheeling direction of the inner ring when viewed in direction X:

- counterclockwise free or
- clockwise free

with lever arm
with rollers



Application as

▶ Backstop

for applications with low to medium speeds in freewheeling operation.

Features

Complete Freewheel FGR ... R A3A4 with lever arm are sealed roller freewheels with ball bearings. They are oil lubricated.

The freewheels FGR ... R A3A4 have an end cover and are fitted to shaft ends.

The oil filling is carried out after the freewheel has been installed.

Nominal torques up to 68 000 Nm.

Bores up to 150 mm.

Application example

Complete Freewheel FGR 45 R A3A4 as a backstop on the opposite ends of the drive shaft of a bucket conveyor. In the case of a motor stop, the bucket conveyor must be held securely so that the conveyor goods do not pull the belt backwards and, in doing so, drive the motor quickly. The backdriving torque is supported by the lever arm with holding pin on the housing. If the holding pin is removed, the belt shaft can be turned in both directions.

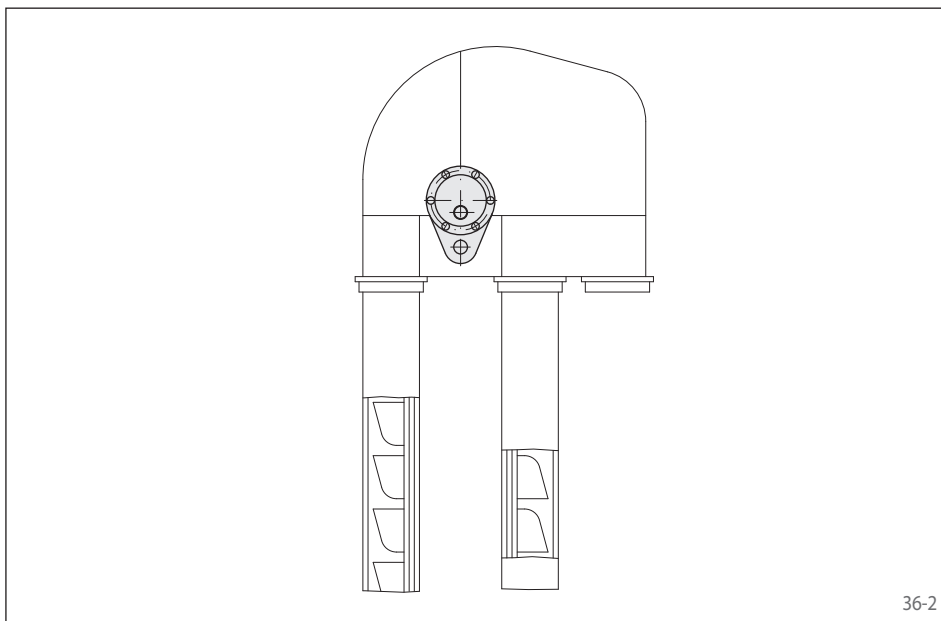

with lever arm
with rollers

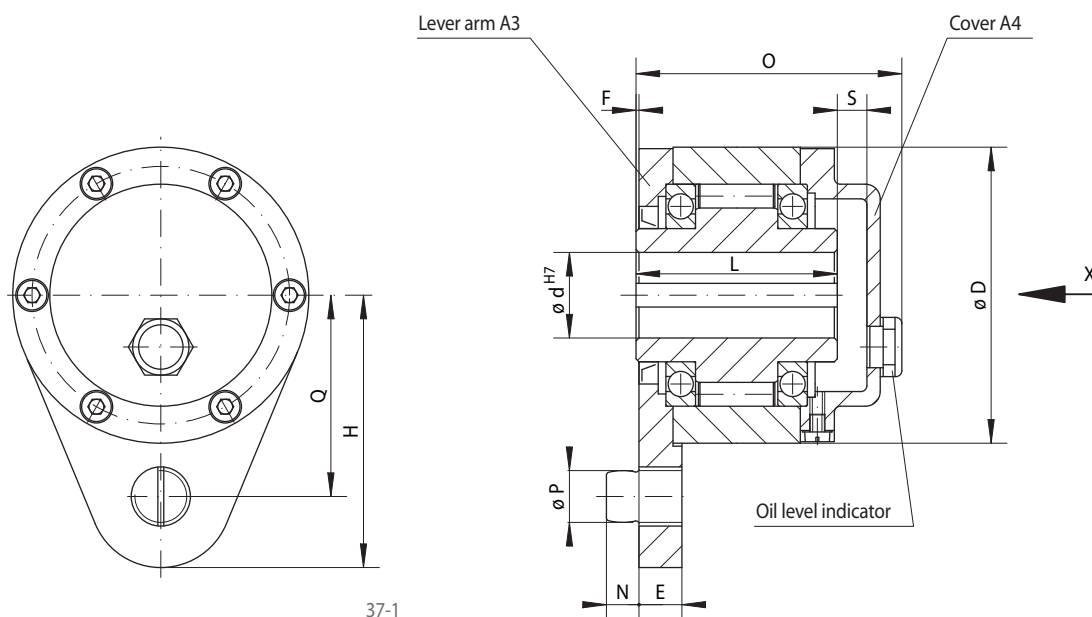

37-1

37-2

		Standard type For universal use			Dimensions											
Freewheel Size	Type	Lever arm and cover combination	Nominal Torque M_N Nm	Max. speed Inner ring freewheels min^{-1}	Bore d mm	D mm	E mm	F mm	H mm	L mm	N mm	O mm	P mm	Q mm	S mm	Weight kg
FGR 12	R	A3A4	55	2 500	12	62	13	1	51	42	10	64	10	44	12	1,4
FGR 15	R	A3A4	130	2 200	15	68	13	1	62	52	10	78	10	47	12	1,8
FGR 20	R	A3A4	180	1 900	20	75	15	1	72	57	11	82	12	54	12	2,3
FGR 25	R	A3A4	290	1 550	25	90	17	1	84	60	14	85	16	62	12	3,4
FGR 30	R	A3A4	500	1 400	30	100	17	1	92	68	14	95	16	68	12	4,5
FGR 35	R	A3A4	730	1 300	35	110	22	1	102	74	18	102	20	76	12	5,6
FGR 40	R	A3A4	1 000	1 150	40	125	22	1	112	86	18	115	20	85	13	8,5
FGR 45	R	A3A4	1 150	1 100	45	130	26	1	120	86	22	115	25	90	14	8,9
FGR 50	R	A3A4	2 100	950	50	150	26	1	135	94	22	123	25	102	15	12,8
FGR 55	R	A3A4	2 600	900	55	160	30	1	142	104	25	138	32	108	18	16,2
FGR 60	R	A3A4	3 500	800	60	170	30	1	145	114	25	147	32	112	18	19,3
FGR 70	R	A3A4	6 000	700	70	190	35	1	175	134	30	168	38	135	17	23,5
FGR 80	R	A3A4	6 800	600	80	210	35	1	185	144	30	178	38	145	17	32,0
FGR 90	R	A3A4	11 000	500	90	230	45	1	205	158	40	192	50	155	17	47,2
FGR 100	R	A3A4	20 000	350	100	270	45	1	230	182	40	217	50	180	17	76,0
FGR 130	R	A3A4	31 000	250	130	310	60	1	268	212	55	250	68	205	18	110,0
FGR 150	R	A3A4	68 000	200	150	400	60	1	325	246	55	286	68	255	20	214,0

■ Freewheels with bore diameters highlighted blue in the table are available with short delivery times.
The maximum transmissible torque is 2 times the specified nominal torque. See page 14 for determination of selection torque.
Keyway according to DIN 6885, page 1 • Tolerance of keyway width JS10.

Mounting

The backdriving torque is supported by the lever arm with holding pin. The holding pin engages in a slot or bore in the frame of the machine. It must have 0,5 to 2 mm play in the axial and radial directions. If the holding pin is removed, the shaft can be turned in both directions.

The tolerance of the shaft must be ISO h6 or j6. In the case of freewheels FGR ... R A3A4, the inner ring must be secured axially with a retainer plate. Prior to commissioning, the freewheel must be filled with oil of the specified quality.

Example for ordering

Basic Freewheel, lever arm, cover, seals and screws are supplied loose provided nothing else is stated in the order.

Freewheel size FGR 25, standard type with lever arm A3 and cover A4:

- FGR 25 R A3A4

with lever arm
with rollers



Application as

▶ Backstop

for applications with low to medium speeds in freewheeling operation.

Features

Complete Freewheel FGR ... R A2A3 with lever arm are sealed roller freewheels with ball bearings. They are oil lubricated.

The freewheels FGR ... R A2A3 are arranged on through shafts or shaft ends.

Nominal torques up to 68 000 Nm.

Bores up to 150 mm.

Application example

Complete Freewheel FGR ... R A2A3 as backstop at the end of an inclined conveyor belt. The backdriving torque is held by lever arm with holding pin on the fundament. When the holding pin is dismantled the conveyor belt can be turned in both directions.

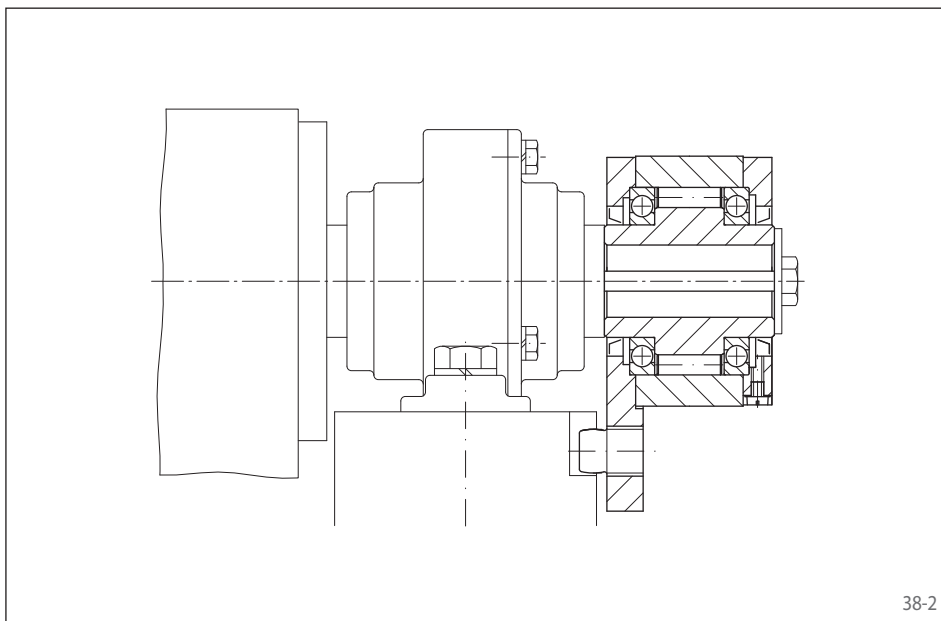

with lever arm
with rollers

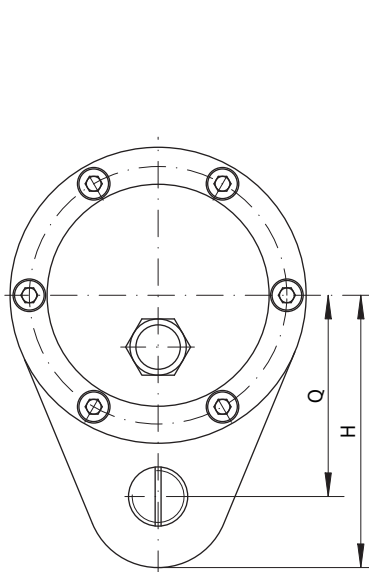

39-1

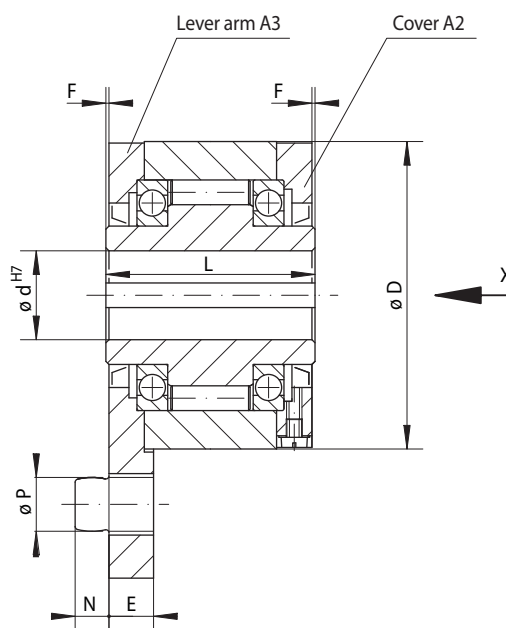

39-2

Backstop	Standard type For universal use		Dimensions												

Freewheel Size	Type	Lever arm and cover combination	Nominal Torque M_N Nm	Max. speed Inner ring freewheels min^{-1}	Bore d mm	D mm	E mm	F mm	H mm	L mm	N mm	O mm	P mm	Q mm	S mm	Weight kg
FGR 12	R	A2A3	55	2 500	12	62	13	1	51	42	10	64	10	44	12	1,4
FGR 15	R	A2A3	130	2 200	15	68	13	1	62	52	10	78	10	47	12	1,8
FGR 20	R	A2A3	180	1 900	20	75	15	1	72	57	11	82	12	54	12	2,3
FGR 25	R	A2A3	290	1 550	25	90	17	1	84	60	14	85	16	62	12	3,4
FGR 30	R	A2A3	500	1 400	30	100	17	1	92	68	14	95	16	68	12	4,5
FGR 35	R	A2A3	730	1 300	35	110	22	1	102	74	18	102	20	76	12	5,6
FGR 40	R	A2A3	1 000	1 150	40	125	22	1	112	86	18	115	20	85	13	8,5
FGR 45	R	A2A3	1 150	1 100	45	130	26	1	120	86	22	115	25	90	14	8,9
FGR 50	R	A2A3	2 100	950	50	150	26	1	135	94	22	123	25	102	15	12,8
FGR 55	R	A2A3	2 600	900	55	160	30	1	142	104	25	138	32	108	18	16,2
FGR 60	R	A2A3	3 500	800	60	170	30	1	145	114	25	147	32	112	18	19,3
FGR 70	R	A2A3	6 000	700	70	190	35	1	175	134	30	168	38	135	17	23,5
FGR 80	R	A2A3	6 800	600	80	210	35	1	185	144	30	178	38	145	17	32,0
FGR 90	R	A2A3	11 000	500	90	230	45	1	205	158	40	192	50	155	17	47,2
FGR 100	R	A2A3	20 000	350	100	270	45	1	230	182	40	217	50	180	17	76,0
FGR 130	R	A2A3	31 000	250	130	310	60	1	268	212	55	250	68	205	18	110,0
FGR 150	R	A2A3	68 000	200	150	400	60	1	325	246	55	286	68	255	20	214,0

■ Freewheels with bore diameters highlighted blue in the table are available with short delivery times.
The maximum transmissible torque is 2 times the specified nominal torque. See page 14 for determination of selection torque.
Keyway according to DIN 6885, page 1 • Tolerance of keyway width JS10.

Mounting

The backdriving torque is supported by the lever arm with holding pin. The holding pin engages in a slot or bore in the frame of the machine. It must have 0,5 to 2 mm play in the axial and radial directions. If the holding pin is removed, the shaft can be turned in both directions.

The tolerance of the shaft must be ISO h6 or j6.

Example for ordering

Basic Freewheel, lever arm, cover, seals and screws are supplied loose provided nothing else is stated in the order.

Freewheel size FGR 25, standard type with cover A2 and lever arm A3:

- FGR 25 R A2A3

If assembled, oil-filled, Complete Freewheels FGR ... R A2A3 are to be supplied, this must be specified in the order. When ordering, please also specify the freewheeling direction of the inner ring when viewed in direction X:

- counterclockwise free or
- clockwise free

Complete Freewheels FRHD

with lever arm
in inch dimension, with sprags

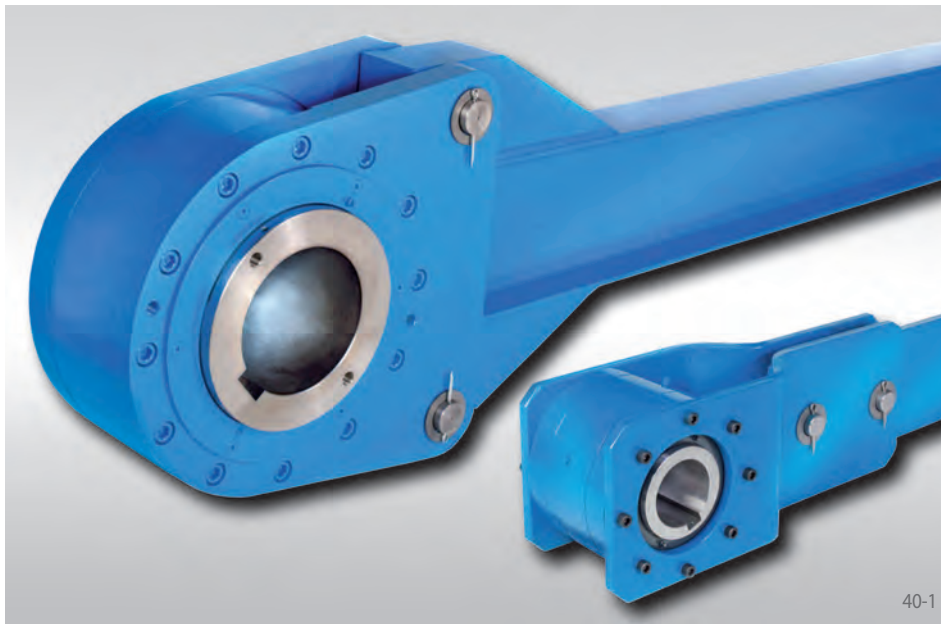

Application as

▶ Backstop

for installations with low speeds. The freewheels are designed for the use in inclined conveyor belts, elevators or pumps. Taconite seals protect the freewheels from contamination with dust or dirt.

Features

Complete Freewheels FRHD with lever arm are sealed sprag freewheels with ball bearings. They are supplied oil-filled and ready for installation. The freewheels are arranged on through shafts or shaft ends.

Nominal torques up to 900 000 lb-ft.

Bores up to 21 inch.

Application example

Backstop FRHD 900 on the head drum shaft of an inclined conveyor belt system. The lever arm is bolted to the freewheel. The backdriving torque is supported by the lever arm on the base plate. When the conveyor belt is without any load, the drum shaft can be turned in both directions during maintenance by removing the bolts.

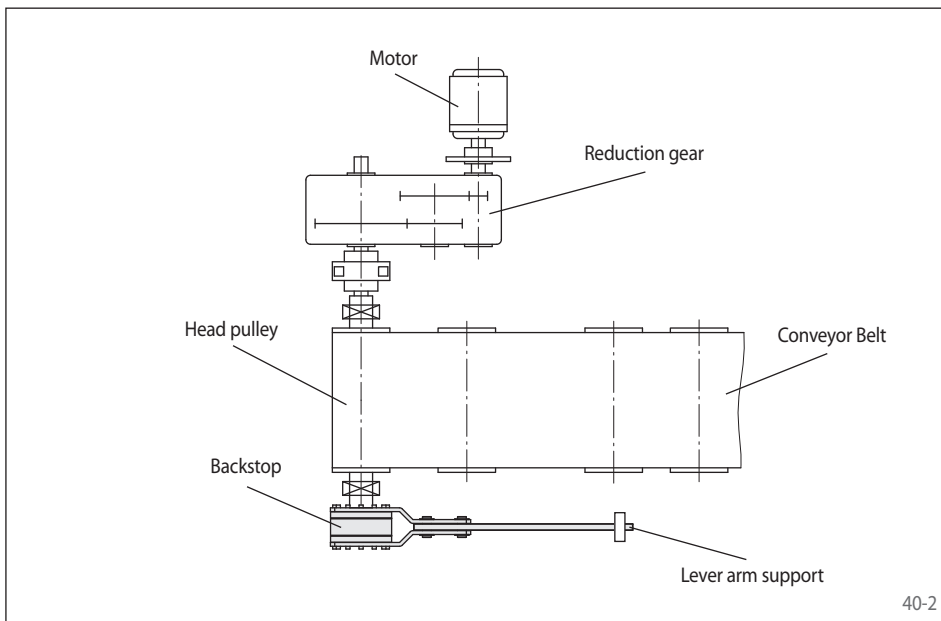

Mounting

The backdriving torque is supported by the lever arm. The lever arm must not be clamped into position. It must have 0,5 inch play in the axial and in the radial direction.

The tolerance of the shaft must be ISO h6 or j6.

Example for ordering

Freewheel size FRHD 800 with a 3,500 inch bore

- FRHD 800, d = 3,5 inch



with lever arm
in inch dimension, with sprags

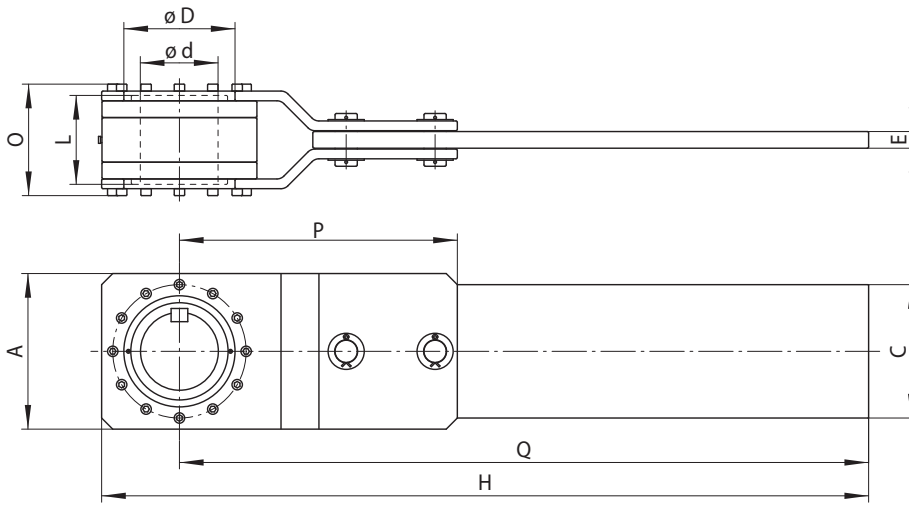

Size FRHD 700 to FRHD 950 and FRHD 1050

41-1

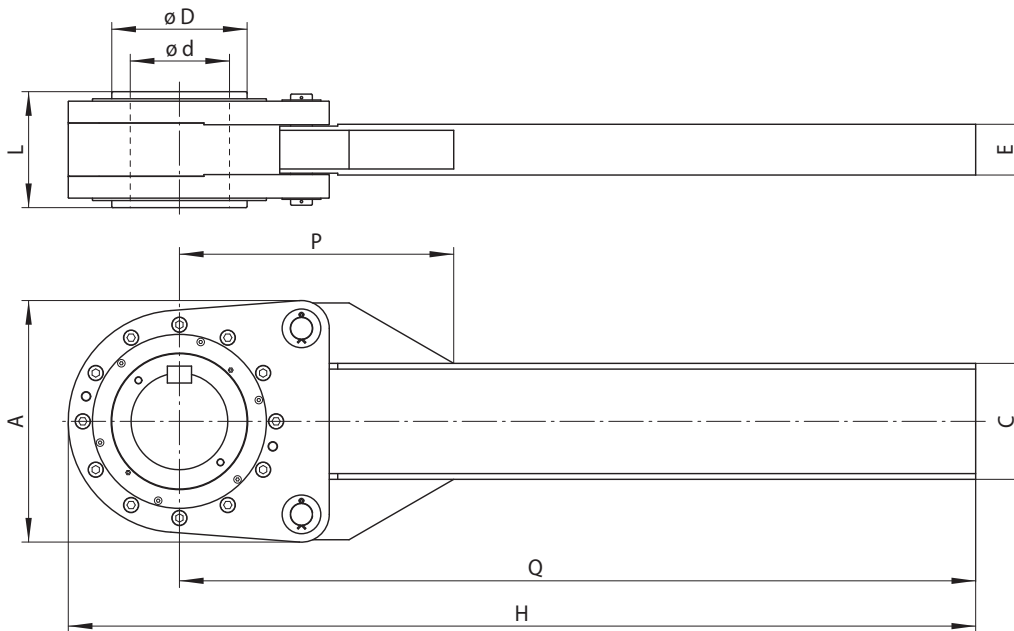

Size FRHD 1000 and FRHD 1100 to FRHD 1800

41-2

Backstop	Standard type	Dimensions											
	For universal use												

Freewheel Size	Nominal torque M_N lb-ft	Max. Speed Inner ring freewheels min^{-1}	Bore d max. inch	A inch	C inch	D inch	E inch	H inch	L inch	O inch	P inch	Q inch	Weight lbs
FRHD 700	3 750	620	3,44	8,00	6,00	5,25	0,50	36,00	6,00	6,75	16,38	32,00	135
FRHD 775	7 500	540	3,75	9,75	8,00	6,00	1,00	42,88	7,50	9,00	20,38	38,00	310
FRHD 800	12 000	460	4,50	10,50	10,00	7,00	1,00	43,25	8,00	9,50	22,13	38,00	360
FRHD 900	18 500	400	5,44	12,00	10,00	8,00	1,50	54,00	7,63	9,38	22,75	48,00	480
FRHD 950	23 000	360	7,00	14,00	12,00	10,00	1,50	69,00	8,00	10,00	25,00	62,00	530
FRHD 1000	28 000	360	7,00	17,00	8,00	9,00	4,13	80,38	8,75	-	23,13	72,00	550
FRHD 1050	45 000	360	7,00	14,00	12,00	10,00	1,50	79,00	10,50	12,50	29,00	72,00	600
FRHD 1100	45 000	360	7,00	17,00	8,00	9,00	4,13	80,38	10,00	-	23,13	72,00	795
FRHD 1200	92 500	250	9,00	23,00	10,00	12,00	4,94	89,00	11,00	-	28,00	78,00	1 300
FRHD 1300	110 000	220	10,00	25,00	12,00	14,00	5,25	95,00	12,00	-	30,00	82,88	1 674
FRHD 1400	140 000	200	12,00	30,00	18,00	16,00	6,25	107,00	13,00	-	36,00	94,00	2 200
FRHD 1450	190 000	200	12,00	30,00	18,00	16,00	6,25	107,00	15,00	-	36,00	94,00	2 500
FRHD 1500	290 000	200	12,00	31,00	18,00	15,13	6,25	107,00	17,62	-	36,00	94,00	2 440
FRHD 1600	373 000	140	14,00	32,50	20,00	17,63	6,25	124,00	19,25	-	30,44	108,00	3 400
FRHD 1700	625 000	120	18,00	42,50	24,50	23,00	7,88	140,00	20,00	-	48,00	120,00	7 000
FRHD 1800	900 000	100	21,00	52,00	30,00	26,50	10,50	170,00	23,00	-	54,00	144,00	12 000

The maximum transmissible torque is 2 times the specified nominal torque. See page 14 for determination of selection torque.
Keyway dimensions upon request by customers. • Conversion factors: 1 lb-ft = 1,35 Nm, 1 inch = 25,4 mm, 1 lbs = 0,453 kg.

Complete Freewheels FA

with lever arm

with sprags and grease lubrication

RINGSPANN®



42-1

Application as

- ▶ Backstop
- ▶ Indexing Freewheel

For application as backstop in installations with low speeds in freewheeling operation. For application as indexing freewheel in installations with low to medium total number of actuations.

Features

Complete Freewheels FA with lever arm are sprag freewheels with sleeve bearings. They are grease-lubricated and therefore maintenance-free.

Besides the standard type, the type with RIDUVIT® is available for extended service life.

Nominal torques up to 2 500 Nm.

Bores up to 85 mm. A multitude of standardized bore diameters are available with short delivery times.

Application example

Complete Freewheel FA 82 SFT as an indexing freewheel for the material feed of a punch. The freewheel is driven by a bell crank. The RIDUVIT® sprags give the freewheel an extended service life.

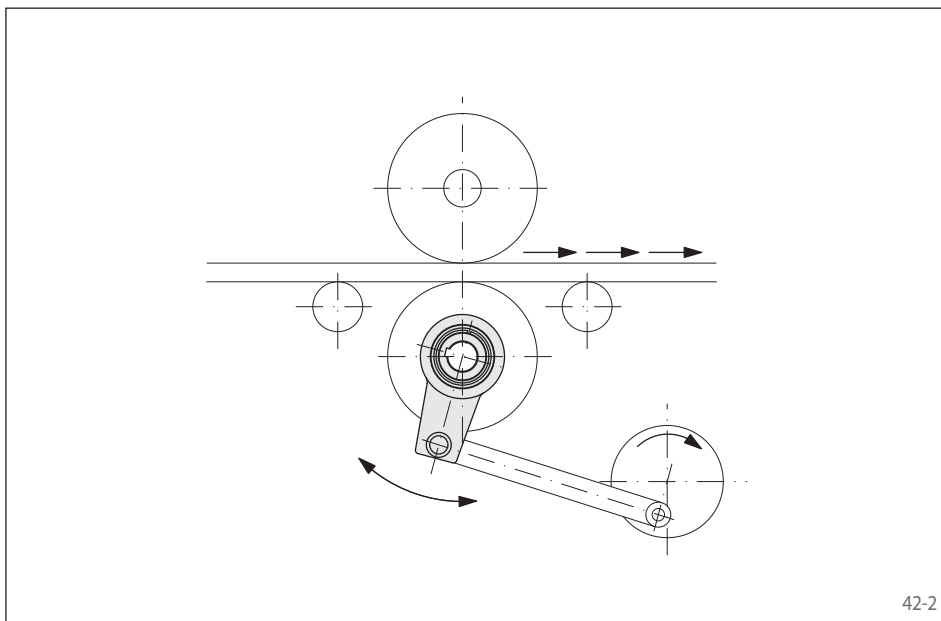

42-2

with lever arm

with sprags and grease lubrication

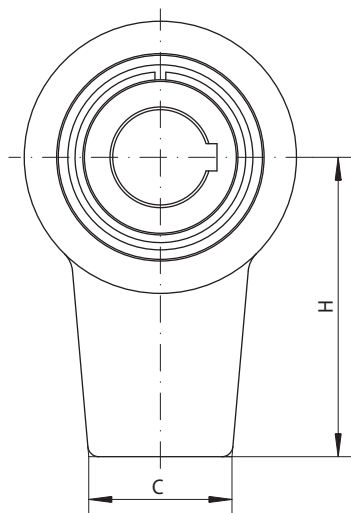

43-1

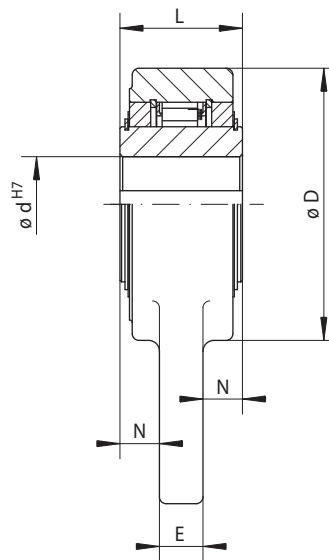

43-2

Indexing Freewheel	Backstop	Standard type	Type with RIDUVIT®	Dimensions
		For universal use	For extended service life with coated sprags	

Freewheel Size	Type	Nominal Torque M_N Nm	Max. speed Inner ring freewheels min^{-1}	Type	Nominal Torque M_N Nm	Max. speed Inner ring freewheels min^{-1}	Bore d		C mm	D mm	E mm	H mm	L mm	N mm	Weight kg
							Standard mm	max. mm							
FA 37	SF	230	250	SFT	230	500	20	25*	35	76	12	90	35	11,5	1,0
FA 57	SF	630	170	SFT	630	340	40	42*	50	100	16	125	45	14,5	2,5
FA 82	SF	1600	130	SFT	1600	260	50	65*	60	140	18	160	60	21,0	5,5
FA 107	SF	2500	90	SFT	2500	180	70	85*	80	170	20	180	65	22,5	8,5

■ Freewheels with bore diameters highlighted blue in the table are available with short delivery times.

The maximum transmissible torque is 2 times the specified nominal torque. See page 14 for determination of selection torque.

Keyway according to DIN 6885, page 1 • Tolerance of keyway width JS10.

* Keyway according to DIN 6885, page 3 • Tolerance of keyway width JS10.

Mounting

When used as a backstop, the backdriving torque is supported by the lever arm. The lever arm must not be clamped into position. It must have 0,5 to 2 mm play in the axial and radial directions.

When used as an indexing freewheel, the lever arm serves as the indexing lever.

The lever arm is not heat treated enabling the customer to provide their own holes.

The tolerance of the shaft must be ISO h6 or j6.

Example for ordering

Freewheel size FA 57, type with RIDUVIT® and 40 mm bore:

- FA 57 SFT, d = 40 mm

Complete Freewheels FAV

with lever arm
with rollers and grease lubrication



Application as

- ▶ Backstop
- ▶ Indexing Freewheel

For application as backstop in installations with low speeds in freewheeling operation.

For application as indexing freewheel in installations with low to medium total number of actuations.

Features

Complete Freewheels FAV with lever arm are roller freewheels with sleeve bearings. They are grease-lubricated and therefore maintenance-free.

Nominal torques up to 2 500 Nm.

Bores up to 80 mm.

Application example

Two Complete Freewheels FAV 50 in the roller feed of a sheet metal processing machine. The indexing freewheel arranged on the left is driven via a bell crank with an adjustable lift. This enables an infinite setting of the feed. The backstop arranged on the right prevents the indexing rollers from running backwards while the indexing freewheel carries out its back stroke. Often, an additional small brake is provided in order to prevent the accelerated sheet metal strip from advancing.

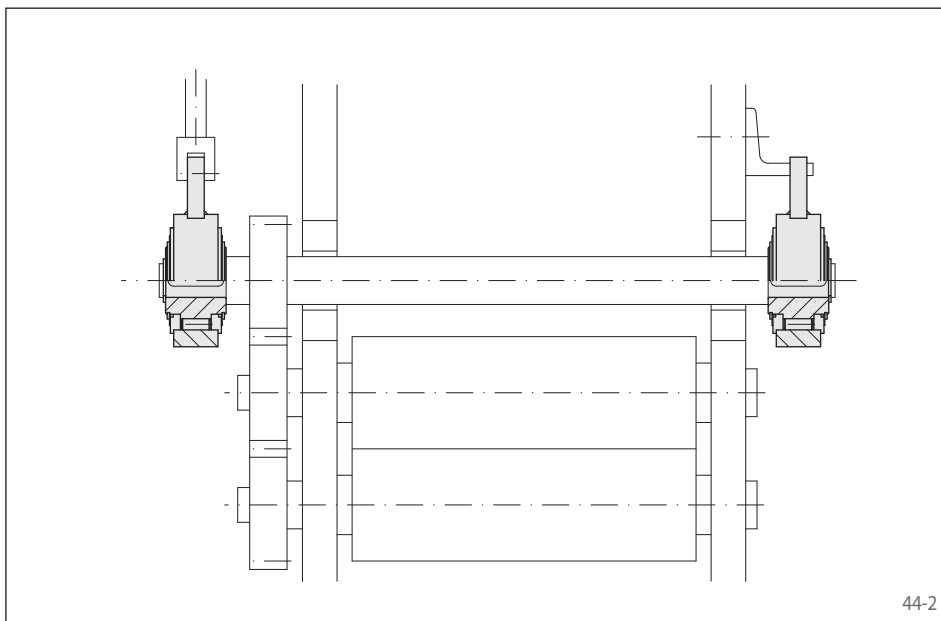

with lever arm
with rollers and grease lubrication

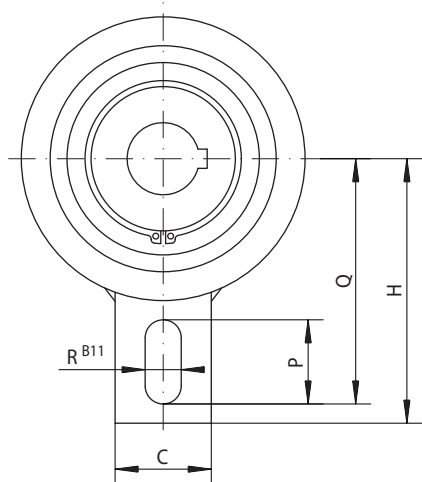

45-1

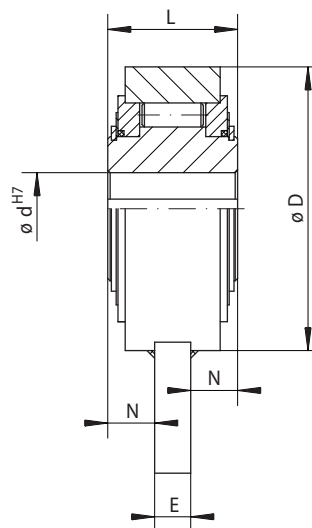

45-2

Indexing Freewheel	Backstop	Standard type	Dimensions										
		For universal use											
Indexing Freewheel	Backstop												

Freewheel Size	Nominal Torque M_N Nm	Max. speed Inner ring freewheels min^{-1}	Bore d mm	C mm	D mm	E mm	H mm	L mm	N mm	P mm	Q mm	R mm	Weight kg
FAV 20	220	500	20	40	83	12	90	35	11,5	35	85	15	1,3
FAV 25	220	500	25	40	83	12	90	35	11,5	35	85	15	1,3
FAV 30	1 025	350	30	40	118	15	110	54	19,5	35	102	15	3,5
FAV 35	1 025	350	35	40	118	15	110	54	19,5	35	102	15	3,4
FAV 40	1 025	350	40	40	118	15	110	54	19,5	35	102	15	3,3
FAV 45	1 600	250	45	80	155	20	140	54	17,0	35	130	18	5,5
FAV 50	1 600	250	50	80	155	20	140	54	17,0	35	130	18	5,4
FAV 55	1 600	250	55	80	155	20	140	54	17,0	35	130	18	5,3
FAV 60	1 600	250	60	80	155	20	140	54	17,0	35	130	18	5,2
FAV 70	1 600	250	70	80	155	20	140	54	17,0	35	130	18	5,0
FAV 80	2 500	220	80	80	190	20	155	64	22,0	40	145	20	9,0

■ Freewheels with bore diameters highlighted blue in the table are available with short delivery times.
The maximum transmissible torque is 2 times the specified nominal torque. See page 14 for determination of selection torque.
Keyway according to DIN 6885, page 1 • Tolerance of keyway width JS10.

Mounting

When used as a backstop, the backdriving torque is supported by the lever arm. The lever arm must not be clamped into position. It must have 0,5 to 2 mm play in the axial and radial directions.

When used as an indexing freewheel, the lever arm serves as the indexing lever.

The tolerance of the shaft must be ISO h6 or j6.

Example for ordering

Freewheel size FAV 60, standard type:

- FAV 60

Complete Freewheels FBE

with shaft coupling for small shaft misalignments
with sprags, available in three types

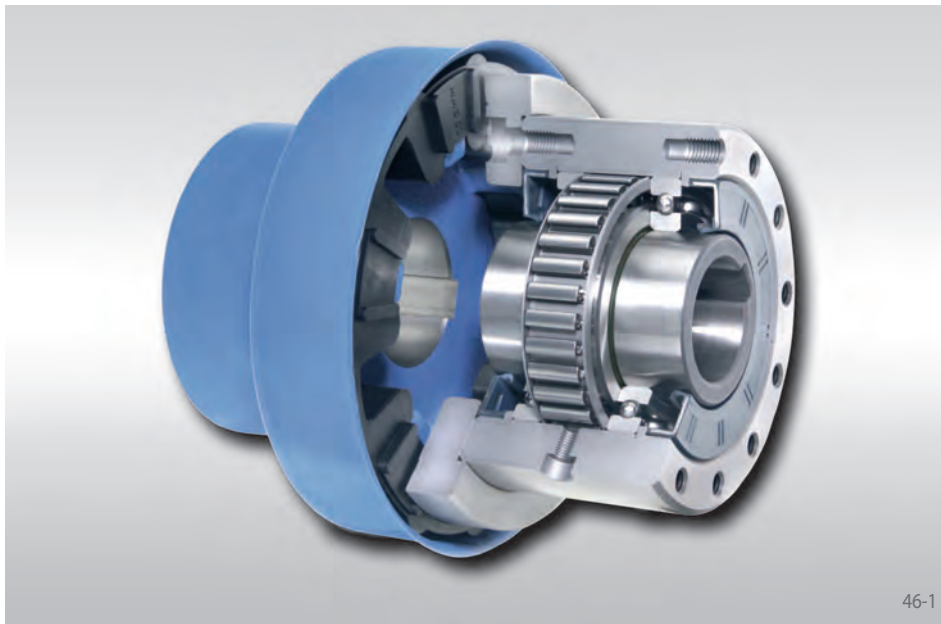

Application as

▶ Overrunning Clutch

Features

Complete Freewheels FBE with flexible shaft coupling are sealed sprag freewheels with ball bearings for coupling two aligned shafts. They are supplied oil-filled and ready for installation.

In addition to the standard type, two other types are available for extended service life.

Nominal torques up to 160 000 Nm.

Bores up to 300 mm. Many standard bores are available.

The material of the flexible coupling element is oil-resistant. We can provide you with performance data for the flexible shaft coupling upon request.

Application example

Two Complete Freewheels FBE 72 with shaft coupling as an overrunning clutch in the drive unit of a tube mill with additional auxiliary drive. A freewheel FBE 72 SF, standard type (freewheel 1) is arranged between the main drive and the angular gear. However, a freewheel FBE 72 LZ, type with sprag lift-off Z (freewheel 2) is arranged between the auxiliary drive and the angular gear. If the gear motor is driving in the auxiliary power mode, freewheel 2 works in driving operation and freewheel 1 overruns at a low speed (freewheeling operation). When driving via the main motor, the unit is driven via freewheel 1 (driving operation). Freewheel 2 overruns and automatically disengages the auxiliary drive (freewheeling operation). With the high speed, the type with sprag lift-off Z is used; the sprags work in freewheeling operation without contact and hence are wear-free.

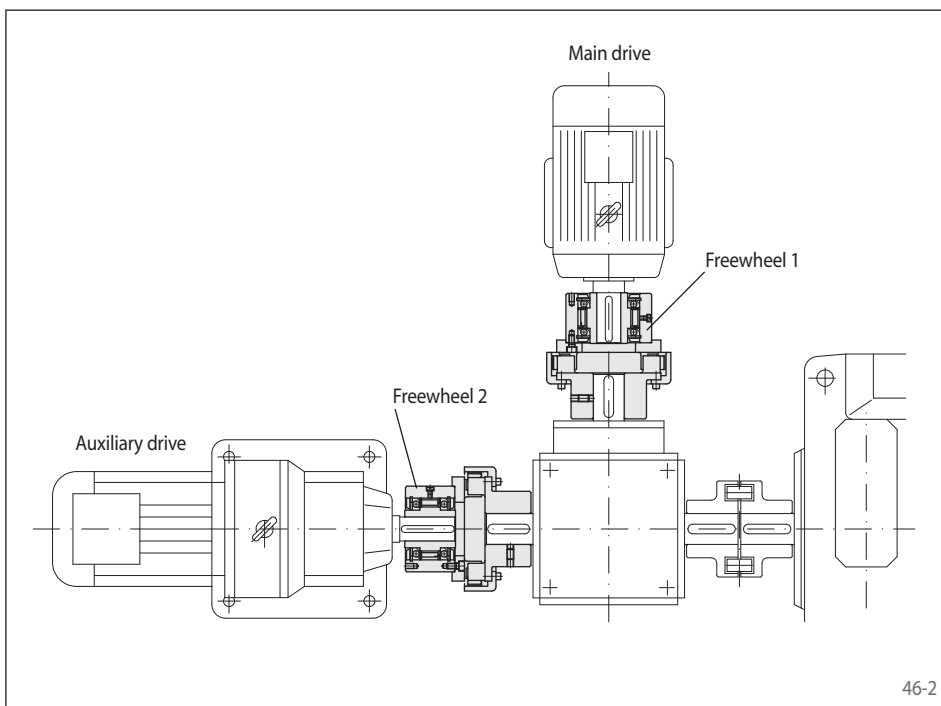

Mounting

The shaft coupling including the fastening screws are supplied loose. Depending on the desired freewheeling direction, the shaft coupling can be fitted on the right or the left of the freewheel.

The tolerance of the shaft must be ISO h6 or j6.

Example for ordering

Freewheel size FBE 107, standard type with 60 mm bore in the freewheel and 55 mm bore in the shaft coupling:

- FBE 107 SF, d1 = 60 mm, d3 = 55 mm

Complete Freewheels FBE

with shaft coupling for small shaft misalignments
with sprags, available in three types

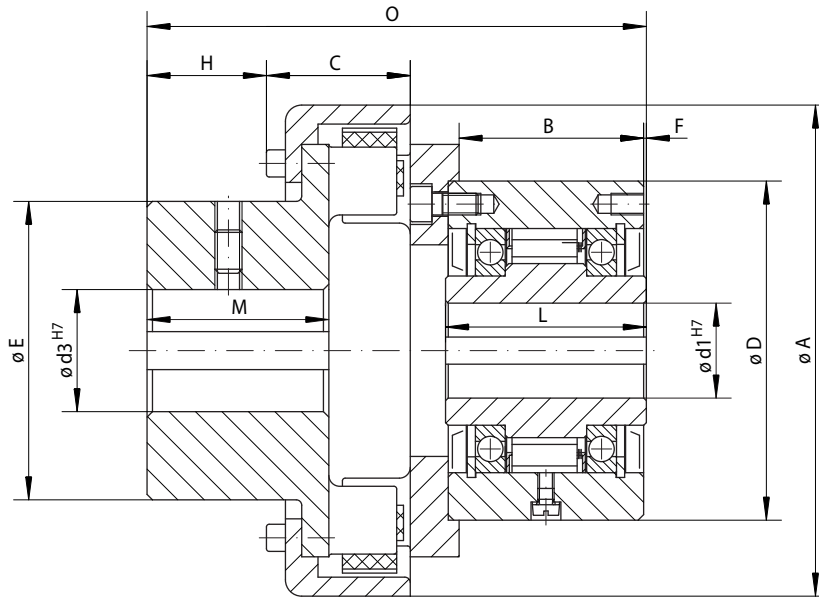

47-1

Overrunning Clutch	Standard type For universal use	Type with RIDUVIT® For extended service life with coated sprags	Type with Sprag lift-off Z For extended service life using sprag lift-off at high speed rotating outer ring

Freewheel Size	Type	Nominal Torque M_N Nm	Max. speed		Type	Nominal Torque M_N Nm	Max. speed		Type	Nominal Torque M_N Nm	Sprag lift-off at outer ring speed min^{-1}	Max. speed	
			Inner ring overruns min^{-1}	Outer ring overruns min^{-1}			Inner ring overruns min^{-1}	Outer ring overruns min^{-1}				Outer ring overruns min^{-1}	Inner ring drives min^{-1}
FBE 24	CF	45	4800	5000	CFT	45	4800	5000					
FBE 29	CF	80	3500	4000	CFT	80	3500	4000					
FBE 37	SF	200	2500	2600	SFT	200	2500	2600	CZ	110	850	3000	340
FBE 44	SF	320	1900	2200	SFT	320	1900	2200	CZ	180	800	2600	320
FBE 57	SF	630	1400	1750	SFT	630	1400	1750	LZ	430	1400	2100	560
FBE 72	SF	1250	1120	1600	SFT	1250	1120	1600	LZ	760	1220	1800	488
FBE 82	SF	1800	1025	1450	SFT	1800	1025	1450	SFZ	1700	1450	1600	580
FBE 107	SF	2500	880	1250	SFT	2500	880	1250	SFZ	2500	1300	1350	520
FBE 127	SF	5000	800	1150	SFT	5000	800	1150	SFZ	5000	1200	1200	480
FBE 140	SF	10000	750	1100	SFT	10000	750	1100	SFZ	10000	950	1150	380
FBE 200	SF	20000	630	900	SFT	20000	630	900	SFZ	20000	680	900	272
FBE 270	SF	40000	510	750	SFT	40000	510	750	SFZ	37500	600	750	240
FBE 340	SF	80000	460	630	SFT	80000	460	630					
FBE 440	SF	160000	400	550	SFT	160000	400	550					

The maximum transmissible torque is 2 times the specified nominal torque. See page 14 for determination of selection torque.

Freewheel Size	Bore d1		Bore d3		A	B	C	D	E	F	H	L	M	O	Weight
	Standard mm	max. mm	min. mm	max. mm											
FBE 24	12	14*	10	35	77	45	30	62	55	1,0	28	50	40	114,0	1,7
FBE 29	15	17*	10	40	90	47	33	68	65	1,0	32	52	45	123,0	2,4
FBE 37	20	22*	10	45	114	44	37	75	72	0,5	28	48	48	122,5	3,1
FBE 44	25*	25*	10	50	127	45	36	90	78	0,5	31	50	52	129,5	4,3
FBE 57	30	32*	20	60	158	60	48	100	96	0,5	39	65	61	162,5	7,3
FBE 72	40	42*	20	70	181	68	53	125	110	1,0	44	74	67	184,0	11,6
FBE 82	50*	50*	25	75	202	67	64	135	120	2,0	46	75	75	200,0	15,4
FBE 107	60	65*	30	80	230	81	75	170	130	2,5	48	90	82	230,0	24,9
FBE 127	70	75*	45	100	294	102	97	200	160	3,0	56	112	97	288,0	47,3
FBE 140	90	95*	60	120	330	135	100	250	200	5,0	80	150	116	350,0	93,3
FBE 200	120	120	85	160	432	143	141	300	255	5,0	104	160	160	408,0	169,0
FBE 270	140	150		180	553	190	197	400	300	6,0	145	212	230	512,0	320,0
FBE 340	180	240		235	725	240	235	500	390	7,5	173	265	285	637,5	580,0
FBE 440	220	300		265	832	290	247	630	435	7,5	183	315	310	737,5	1206,0

For bore d1: Keyway according to DIN 6885, page 1 • Keyway width tolerance JS10. * Keyway according to DIN 6885, page 3 • Keyway width tolerance JS10.

For bore d3: Keyway according to DIN 6885, page 1 • Keyway width tolerance P9

Complete Freewheels FBL

with shaft coupling for large shaft misalignments
with sprags, available in three types

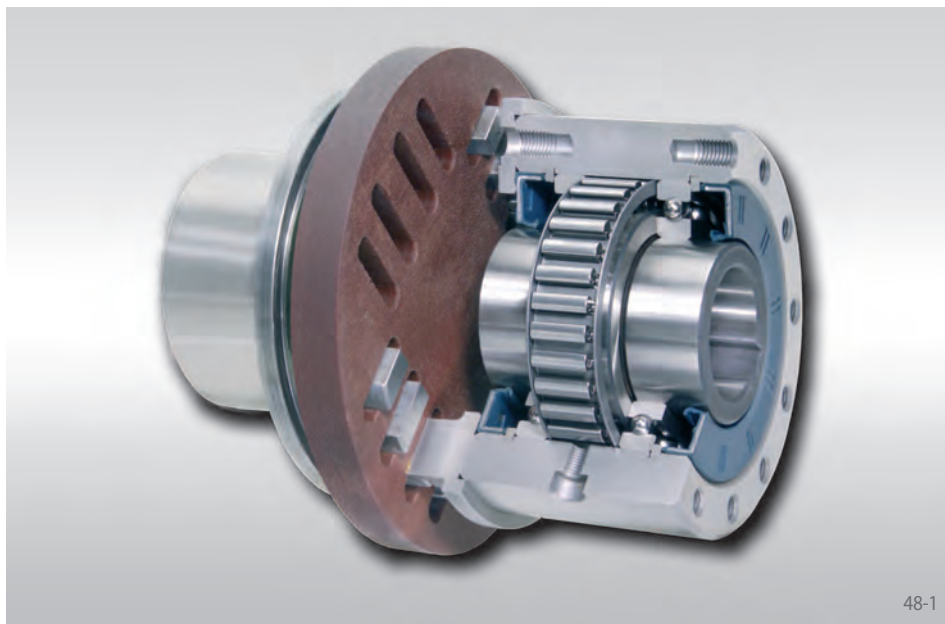

Application as

▶ Overrunning Clutch

Features

Complete Freewheels FBL with RINGSPANN shaft coupling are sealed sprag freewheels with ball bearings for coupling two shafts. They are supplied oil-filled and ready for installation

In addition to the standard type, two other types are available for extended service life.

Nominal torques up to 8 000 Nm.

Bores up to 140 mm. Many standard bores are available.

The torsionally stiff RINGSPANN-Shaft Coupling can accept large radial and angular misalignments, without reactive forces affecting neighbouring bearings. We can provide you with performance data upon request.

Application example

Complete Freewheel FBL 82 SFZ as an overrunning clutch in the drive unit of a conveyor belt system with additional creep drive. The freewheel with shaft coupling is arranged in between the main motor and the creep drive. When the creep drive operates, the freewheel is in driving operation and drives the belt at low speed. In normal operation (freewheeling operation), the main motor drives and the outer ring overruns, whereupon the creep drive is automatically disengaged. With the high speed here, the type sprag lift-off Z is used; the sprags work in freewheeling operation without contact and hence are wear-free.

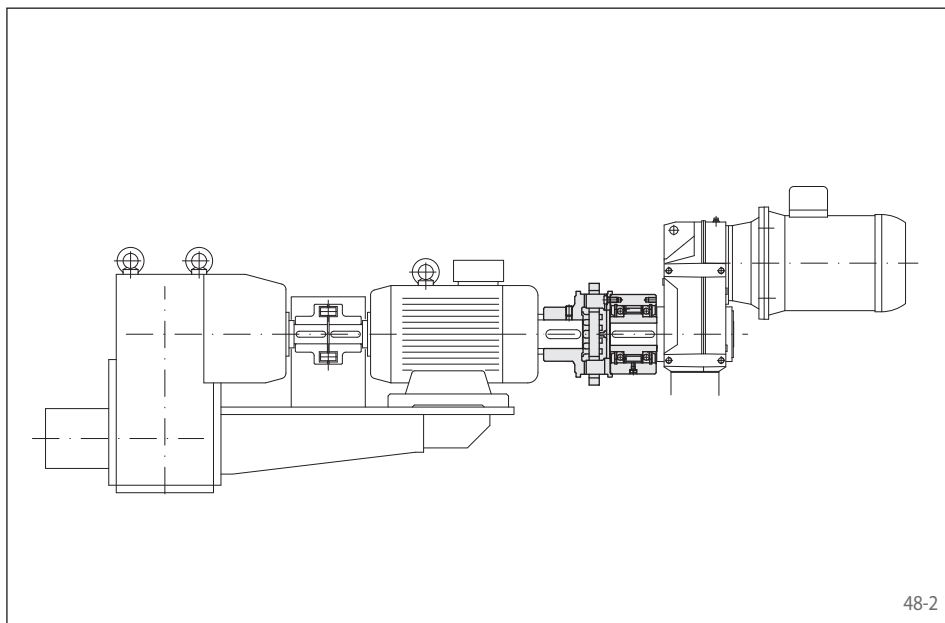

with shaft coupling for large shaft misalignments
with sprags, available in three types

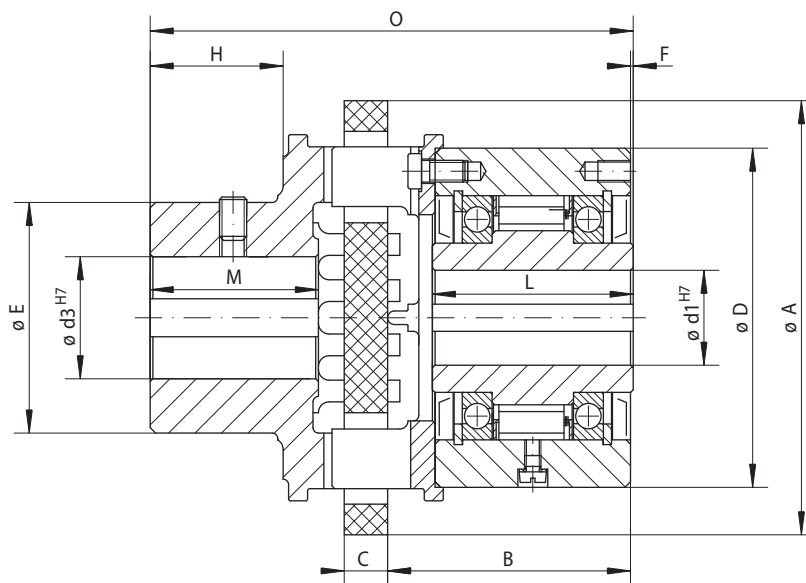

49-1

Overrunning Clutch	Standard type For universal use	Type with RIDUVIT® For extended service life with coated sprags	Type with Sprag lift-off Z For extended service life using sprag lift-off at high speed rotating outer ring

Freewheel Size	Type	Nominal Torque M_N Nm	Max. speed		Type	Nominal Torque M_N Nm	Max. speed		Type	Nominal Torque M_N Nm	Sprag lift-off at outer ring speed min^{-1}	Max. speed	
			Inner ring overruns min^{-1}	Outer ring overruns min^{-1}			Inner ring overruns min^{-1}	Outer ring overruns min^{-1}				Outer ring overruns min^{-1}	Inner ring drives min^{-1}
FBL 37	SF	85	2500	2600	SFT	85	2500	2600	CZ	85	850	3000	340
FBL 44	SF	190	1900	2200	SFT	190	1900	2200	CZ	180	800	2600	320
FBL 57	SF	500	1400	1750	SFT	500	1400	1750	LZ	430	1400	2100	560
FBL 72	SF	500	1120	1600	SFT	500	1120	1600	LZ	500	1220	1800	488
FBL 82	SF	1000	1025	1450	SFT	1000	1025	1450	SFZ	1000	1450	1600	580
FBL 107	SF	2000	880	1250	SFT	2000	880	1250	SFZ	2000	1300	1350	520
FBL 127	SF	4000	800	1150	SFT	4000	800	1150	SFZ	4000	1200	1200	480
FBL 140	SF	8000	750	1050	SFT	8000	750	1050	SFZ	8000	950	1050	380

The maximum transmissible torque is 2 times the specified nominal torque. See page 14 for determination of selection torque.

Freewheel Size	Bore d1		Bore d3		A	B	C	D	E	F	H	L	M	O	Weight
	Standard mm	max. mm	min. mm	max. mm											
FBL 37	20	22*	14	35	110	62,0	12	75	53	0,5	33	48	42	124	3,0
FBL 44	25*	25*	20	42	135	65,0	14	90	66	0,5	41	50	53	140	4,6
FBL 57	30	32*	30	50	160	82,5	16	100	85	0,5	51	65	62	170	6,9
FBL 72	40	42*	30	50	160	89,5	16	125	85	1,0	51	74	62	178	10,0
FBL 82	50*	50*	40	70	200	92,0	20	135	104	2,0	65	75	79	204	14,2
FBL 107	60	65*	50	90	250	111,5	25	170	150	2,5	81	90	100	250	28,0
FBL 127	70	75*	60	110	315	138,0	32	200	175	3,0	101	112	124	313	48,8
FBL 140	90	95*	75	140	400	183,5	40	250	216	5,0	130	150	160	410	102,2

For bore d1: Keyway according to DIN 6885, page 1 • Keyway width tolerance JS10. * Keyway according to DIN 6885, page 3 • Keyway width tolerance JS10.
For bore d3: Keyway according to DIN 6885, page 1 • Keyway width tolerance P9

Mounting

The flexible disk of the shaft coupling must be axially free when fitted so that the ball bearings in the freewheel are not distorted due to heat expansion.

The shaft coupling including the fastening screws are supplied loose. Depending on the desired freewheeling direction, the shaft coupling can be fitted on the right or the left of the freewheel.

The tolerance of the shaft must be ISO h6 or j6.

Example for ordering

Freewheel size FBL 72, type with sprag lift-off Z and 40 mm bore in the freewheel and 50 mm bore in the shaft coupling:

- FBL 72 LZ, d1 = 40 mm, d3 = 50 mm

Housing Freewheels FH

for stationary arrangement in multimotor drives
with hydrodynamic roller lift-off for extended service life

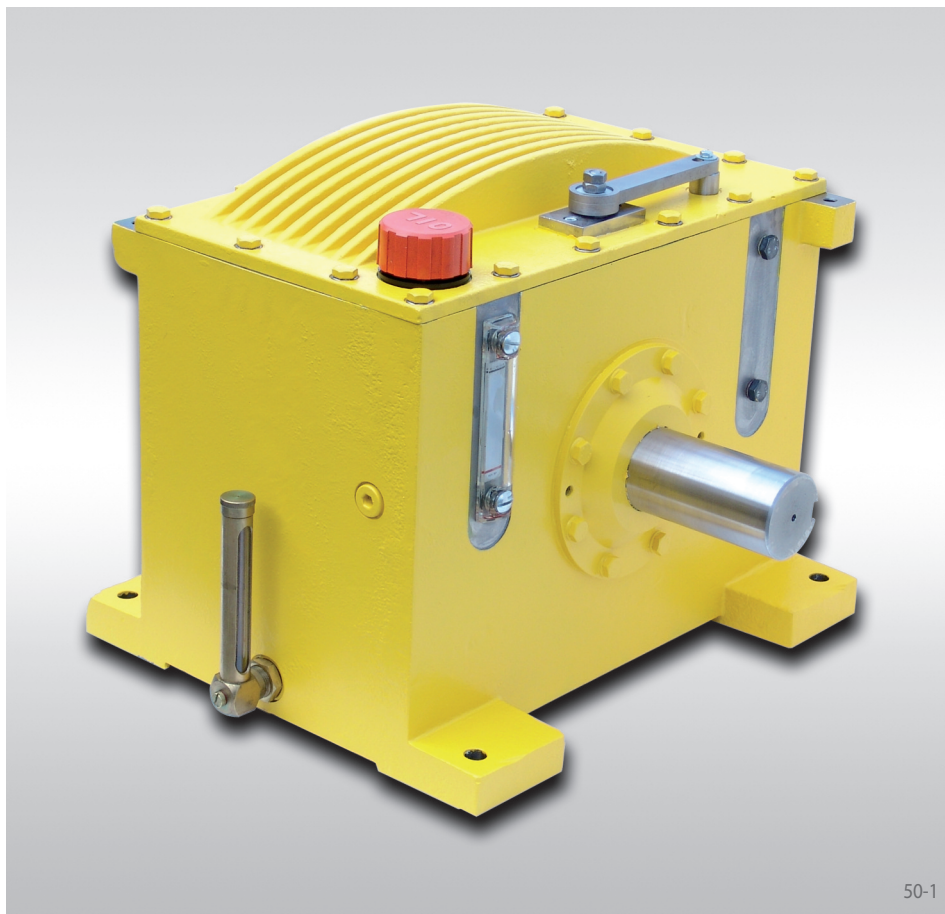

Application as

▶ Overrunning Clutch

at high speeds, which are the same or similar in freewheeling operation and in driving operation.

Features

Housing Freewheels FH with hydrodynamic roller lift-off are typically used in cases where an assembly can be driven from two or more motors or turbines at the same or similar high speed. They allow a continuous plant operation in the event that one of the energy sources or a drive line fails as well as energy saving in the case of partial load operation.

The Housing Freewheels FH are completely enclosed freewheels for stationary arrangement with input and output shaft.

Advantages

- Nominal torques up to 40675 Nm
- Shaft diameter up to 129 mm
- Wear-free operation
- Low noise
- Low power dissipation
- Integrated oil filtration system
- Integrated locking brake
- Oil change without down time

Hydrodynamic roller lift-off

Housing Freewheels FH are equipped with hydrodynamic roller lift-off. The hydrodynamic roller lift-off is the ideal solution for overrunning

clutches at high speeds, not only in freewheeling operation, but also in the driving operation, as can occur, for example, in multimotor drives.

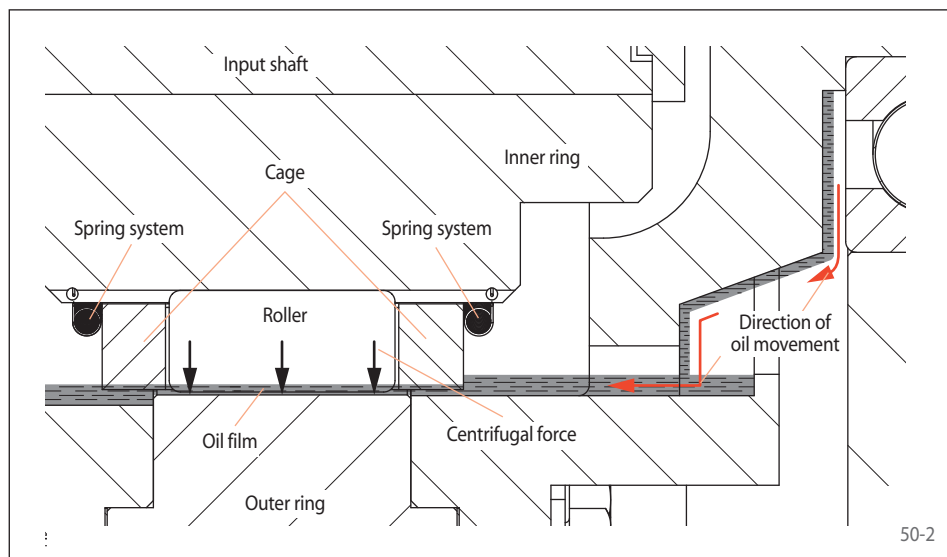

In the case of hydrodynamic roller lift-off, the lifting force is generated by an oil film applied during freewheeling operation by centrifugal force exerted on the outer ring race. This provides for practically wear-free freewheeling operation. The speed differential between the inner and outer rings is the decisive factor affecting the lift-off function. If the speed differential decreases, the lift-off force also decreases. Before achieving synchronous running, the clamping rollers guided in a cage are positioned with the aid of the central spring system against the outer ring race and are then ready to lock. This guarantees immediate torque transfer once the synchronous speed has been reached. The hydrodynamic roller lift-off enables a virtually wear-free freewheeling operation.

for stationary arrangement in multimotor drives
with hydrodynamic roller lift-off for extended service life

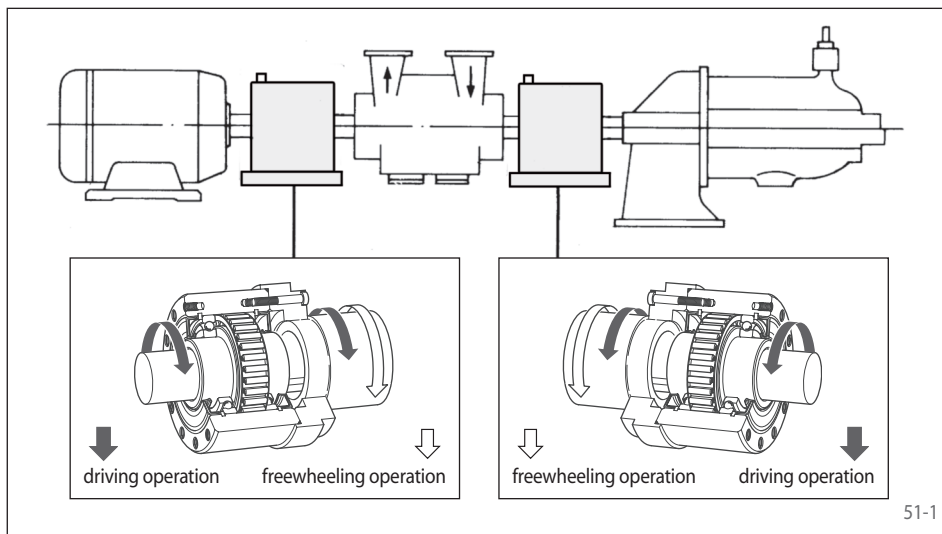

Areas of application

Housing Freewheels as automatic clutches in multimotor drives fulfil here an important function. They disengage a drive automatically as soon as it no longer provides power to the working machine. The Housing Freewheels do not require any external operating equipment. Typical applications for multimotor drives are:

- Generators
- Pumps
- Ventilators
- Fans
- Uninterrupted power supply

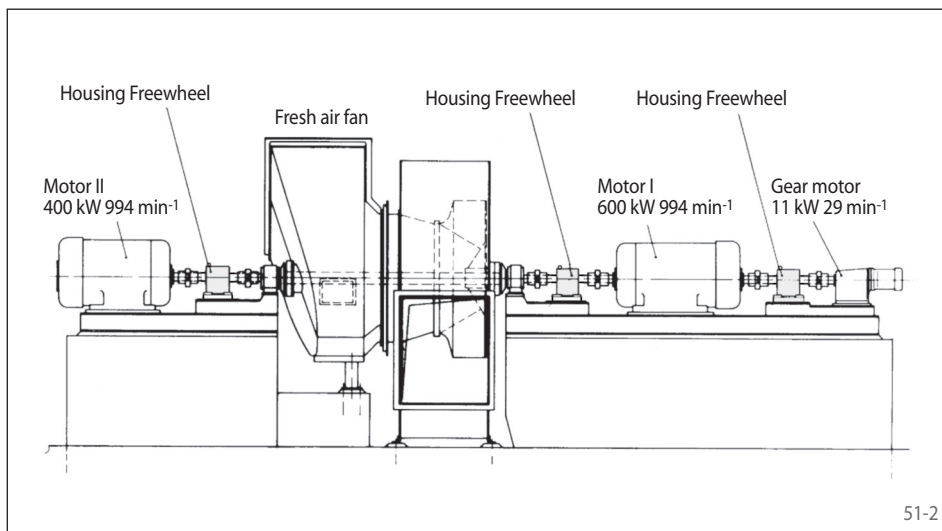

Application example

Three Housing Freewheels in the multimotor drive of a fresh air fan. The fan is driven by one or two electric motors. An additional auxiliary drive serves to slowly turn the fan for the purposes of inspection work or for an even cooling down after shut down. The Housing Freewheels automatically engage the respective working electric motor to the fan.

Selection torque for Housing Freewheels FH

In many cases where overrunning clutches are being used, dynamic processes occur that cause high peak torques. In the case of overrunning clutches, the torques that occur during start up must be observed. The peak torques when starting up can, in the case of asynchronous motors - especially when accelerating large masses and when using elastic couplings - significantly exceed the torque calculated from the motor pullover torque. The conditions for internal combustion engines are similar. Even in normal operation, on account of their degree of irregularity, peak torques can occur that are way in excess of the nominal torque.

The prior determination of the maximum occurring torque is carried out most safely by using a rotational vibration analysis of the entire system. This, however, requires a knowledge of the rotating masses, the rotational

rigidity and all of the excitation moments that occur on the system. In many cases, a vibrational calculation is too time consuming or you may not have all the necessary data in the configuration phase available. In this case, the selection torque M_A of the overrunning clutch should be determined as follows:

$$M_A = K \cdot M_L$$

In this equation:

M_A = Selection torque of the freewheel

K = Operating factor

M_L = Load torque for constant rotating freewheel:
= $9550 \cdot P_0 / n_{FR}$

P_0 = Nominal power of motor [kW]

n_{FR} = Speed of the freewheel in driving operation [min⁻¹]

After calculating M_A the freewheel size must be selected in accordance with the catalogue tables in such a way that in all cases this applies:

$$M_N \geq M_A$$

M_N = Nominal torque of the Housing Freewheel FH in accordance with the table values [Nm]

The operating factor K depends on the properties of the driver and the machine. The general rules of mechanical engineering apply here. We recommend using an operating factor K of at least 1,5. We will be pleased to check your selection.

Housing Freewheels FH

for stationary arrangement in multimotor drives
with hydrodynamic roller lift-off for extended service life

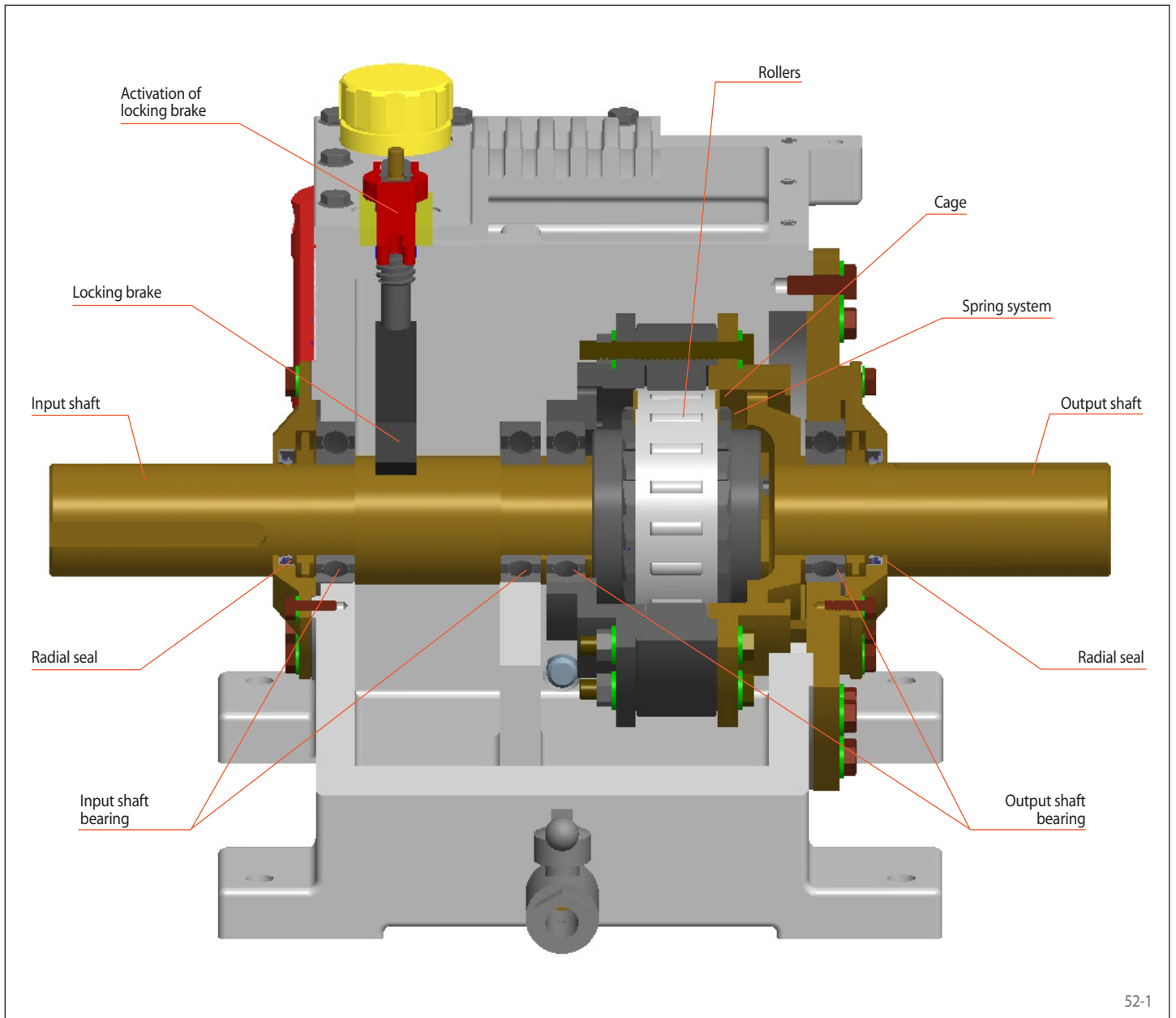

52-1

Housing Freewheels FH

for stationary arrangement in multimotor drives
with hydrodynamic roller lift-off for extended service life

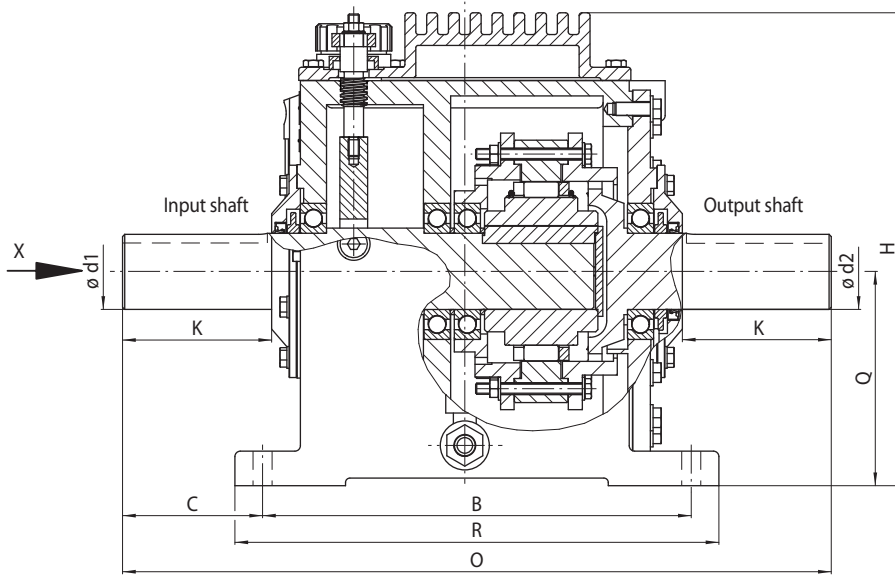

53-1

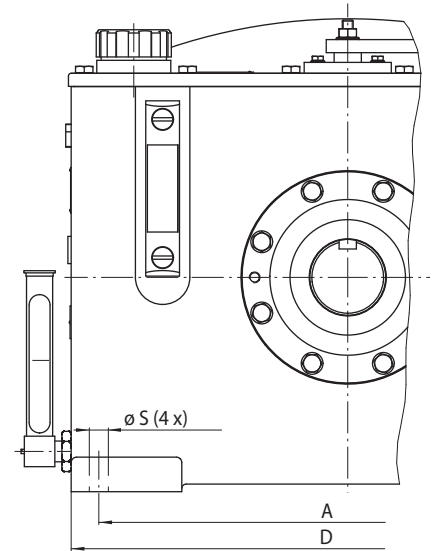

53-2

Housing Freewheels

Overrunning Clutch	Type hydrodynamic roller lift-off	Dimensions

	Freewheel Size	Type	Nominal torque M_N	Max. speed		Shaft d1 and d2	A	B	C	D	H	K	O	Q	R	S	Weight
				Output shaft overruns	Input shaft drives												
inch	FH 1000	R	1000	5600	5600	1 3/4	12 3/4	12 3/4	3 7/16	16 1/4	12 7/8	3 7/8	19 5/8	5 3/4	14 1/2	11 1/16	231
	FH 2000	R	2000	4200	4200	2 5/16	16 3/4	14 3/4	4 1/4	18 3/4	15	4 5/8	23 1/4	6 7/8	16 1/2	11 1/16	355
	FH 4000	R	4000	3600	3600	2 3/4	18	15 1/2	5 1/16	20	17 1/8	5 3/8	25 5/8	7 3/4	17 1/2	11 1/16	496
	FH 8000	R	8000	3000	3000	3 5/16	17 1/2	18 1/4	5 5/8	21 1/2	18 15/16	6 1/8	29 1/2	8 5/8	20 1/2	13 1/16	716
	FH 12000	R	12000	2500	2500	3 7/8	18 1/4	21 1/2	6 5/16	22 3/4	20 15/16	6 15/16	34 1/8	9 5/8	23 3/4	1 1/16	926
	FH 18000	R	18000	2300	2300	4 5/16	20 1/2	23 1/4	7 5/16	26	20 5/8	7 11/16	37 7/8	11 1/4	25 3/4	1 5/16	1402
FH 30000	R	30000	2000	2000	5 1/16	25 1/2	26 1/4	7 7/8	31	26 1/2	8 5/8	42	12 3/4	29 1/2	1 5/16	2178	
metric			Nm	min ⁻¹	min ⁻¹	mm	mm	mm	mm	mm	mm	mm	mm	mm	mm	mm	kg
	FH 1000	R	1356	5600	5600	44,45	323,85	323,85	87,31	412,75	327,00	98,43	498,48	146,05	368,30	17,50	105
	FH 2000	R	2712	4200	4200	58,74	425,45	374,65	107,95	480,00	381,00	117,48	590,55	174,63	419,10	17,50	161
	FH 4000	R	5423	3600	3600	69,85	457,20	393,70	128,59	508,00	435,00	136,53	650,88	196,85	444,50	17,50	225
	FH 8000	R	10847	3000	3000	84,14	444,50	463,55	142,87	546,00	481,00	155,58	749,30	219,08	520,00	21,00	325
	FH 12000	R	16270	2500	2500	98,43	463,55	546,10	160,35	578,00	532,00	177,00	866,80	244,48	603,00	27,00	425
FH 18000	R	24405	2300	2300	109,54	520,70	590,55	185,74	660,00	600,00	195,26	962,00	285,75	654,00	33,00	636	
FH 30000	R	40675	2000	2000	128,59	647,70	666,75	200,03	787,00	672,00	220,00	1066,80	323,85	749,00	33,00	988	

The maximum transmissible torque is 2 times the specified nominal torque. See page 14 for determination of selection torque.
Keyway according to USAS B17.1-1967

Locking brake

During freewheeling operation, the stationary input shaft of the Housing Freewheel is effected by a drag torque from the freewheeling output shaft. By manually activation of the in the housing freewheel integrated locking brake the driving parts are prevented from being carried along.

Mounting

The Housing Freewheel must be mounted in such a way that shaft d1 is the input shaft and shaft d2 the output shaft.

We recommend the use of torsionally stiff shaft couplings generating only low reactive forces. On indication of the reactive forces that occur we are well prepared to check the usable life of the bearings installed.

Example for ordering

Prior to ordering, please complete the questionnaire on page 113 by specifying the direction of rotation in driving operation when viewed in direction X so that we can check the selection.

Housing Freewheel FCBM

Backstop for Kiln drives
with electromagnetic and manual release function

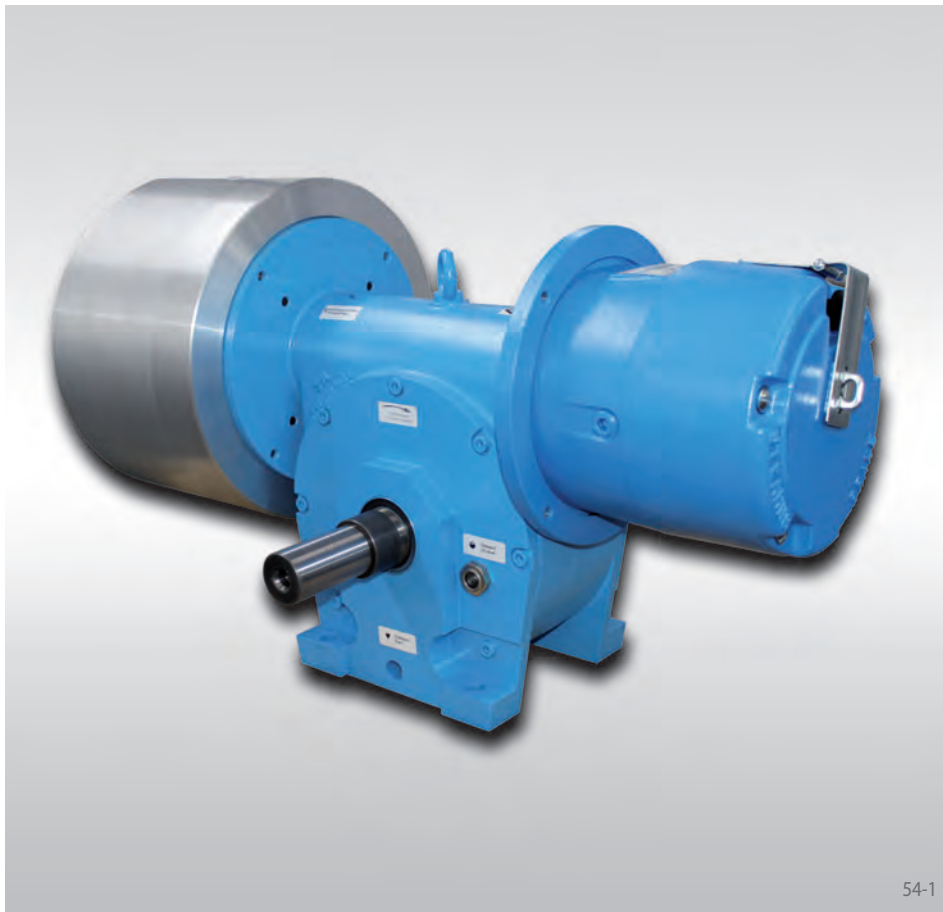

Application as

- ▶ Backstop

Features

The Housing Freewheel FCBM is used to control reverse rotation of the kiln when a rotary kiln drive is shut down. It is equipped with a Cage Freewheel on the main shaft and a multi-disc brake as well as a centrifugal brake on the worm shaft.

When the rotary kiln drive is shut down, the Cage Freewheel automatically engages the main shaft and the worm shaft. The closed multi-disc brake prevents reverse rotation of the rotary kiln. Through electromagnetic or manual releasing of the multi-disc brake, the controlled reverse rotation of the rotary kiln is then initiated. During reverse rotation, the centrifugal brake is used to ensure a controlled low speed of the rotary kiln until it has come to a stand still.

The Housing Freewheels FCBM is a completely enclosed freewheel for stationary arrangement with input and output shaft. It was developed to protect people and machines from injury and damage.

Technical data

- Nominal torque 750 Nm
- Maximum overrunning speed 1600 min⁻¹
- Oil capacity of 2,75 liter
- Weight 190 kg

Application example

The Housing Freewheel FCBM is usually arranged in rotary kiln drives between the auxiliary drive and auxiliary gear box, as shown in Fig. 54-2. It makes a controlled reverse rotation of the rotary kiln possible.

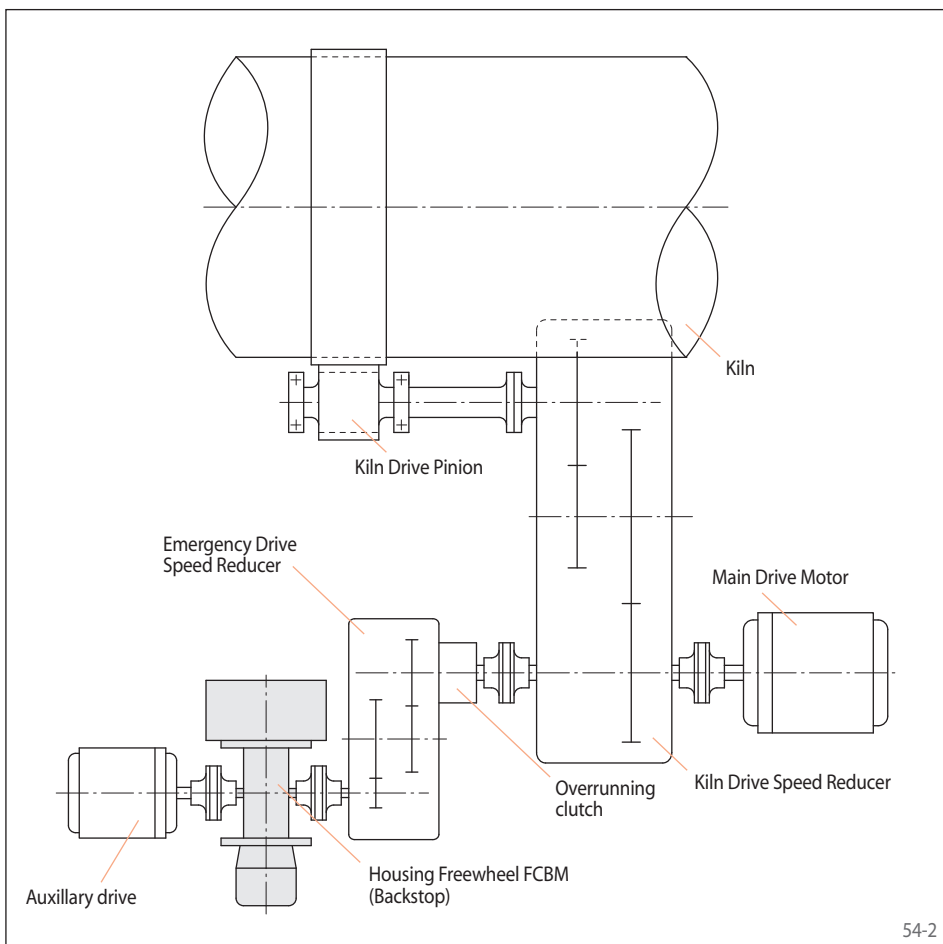

54-1

54-2

Backstop for Kiln drives with electromagnetic and manual release function

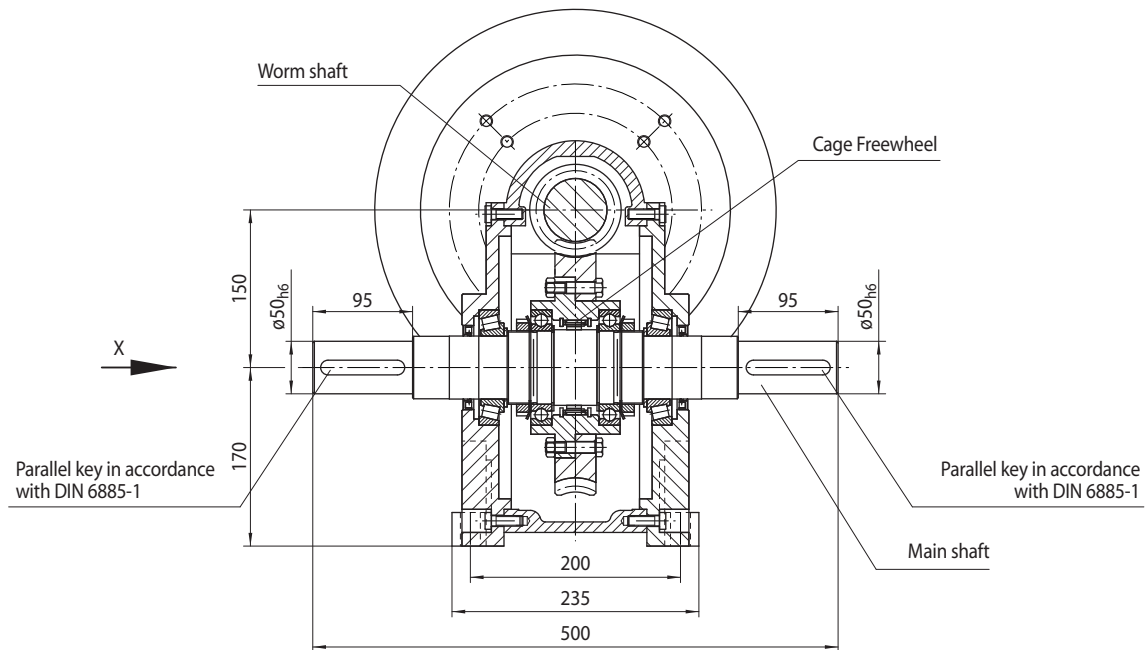

55-1

View „X“

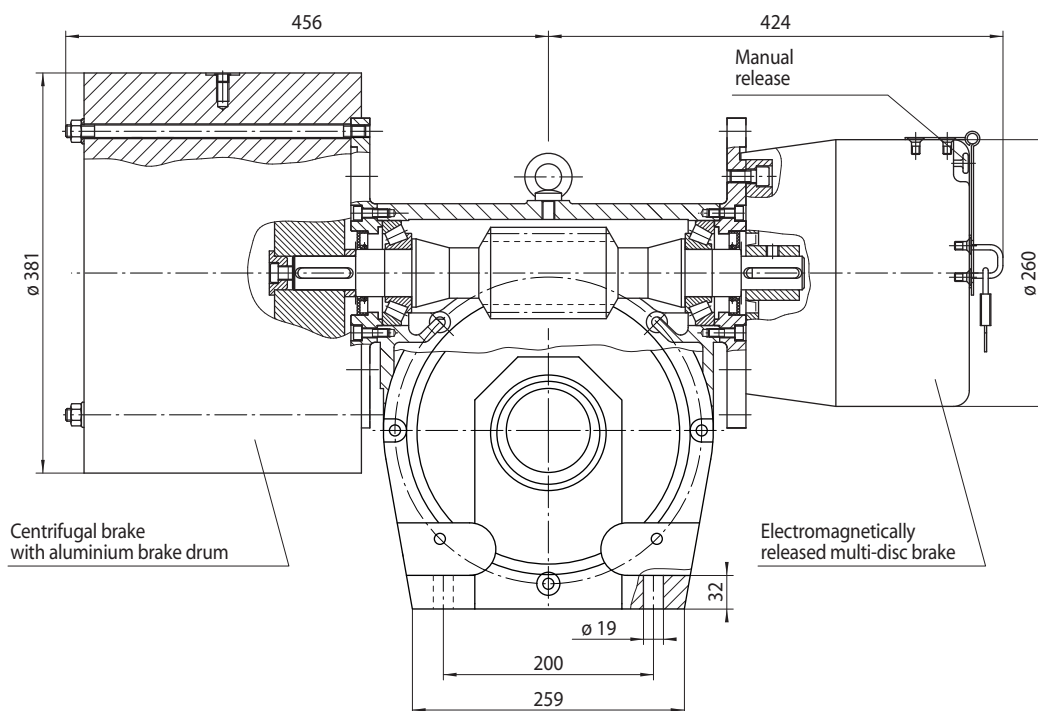

55-2

Power supply

The following power supplies are available for the electromagnetically released multi-disc brake:

- 230 VAC +/- 10% (207-253 V) at 50 Hz
- 400 VAC +/- 10% (360-440 V) at 50 Hz
- 115 VAC +/- 10% (103-126 V) at 60 Hz

Special voltages can be customised as requested. Please indicate such voltages on the selection sheet on page 114.

Example for ordering

Prior to ordering, please complete the questionnaire on page 114 so that we can check the selection.

Basic Freewheels FBO

for assembly with connecting parts
with sprags, available in four types

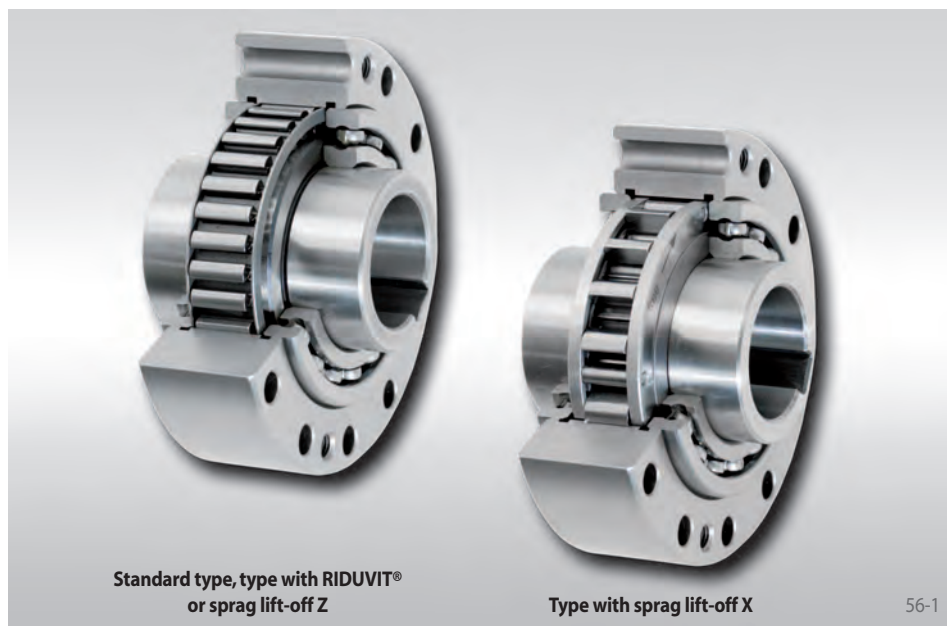

Application as

- ▶ Backstop
- ▶ Overrunning Clutch
- ▶ Indexing Freewheel

Features

Basic Freewheels FBO are sprag freewheels with ball bearings to be assembled with customer connecting parts. The freewheels are particularly suitable for installation in housings with oil lubrication and seals.

In addition to the standard type, three other types are available for extended service life.

Nominal torques up to 160 000 Nm.

Bores up to 300 mm. A multitude of standardized bore diameters are available with short delivery times.

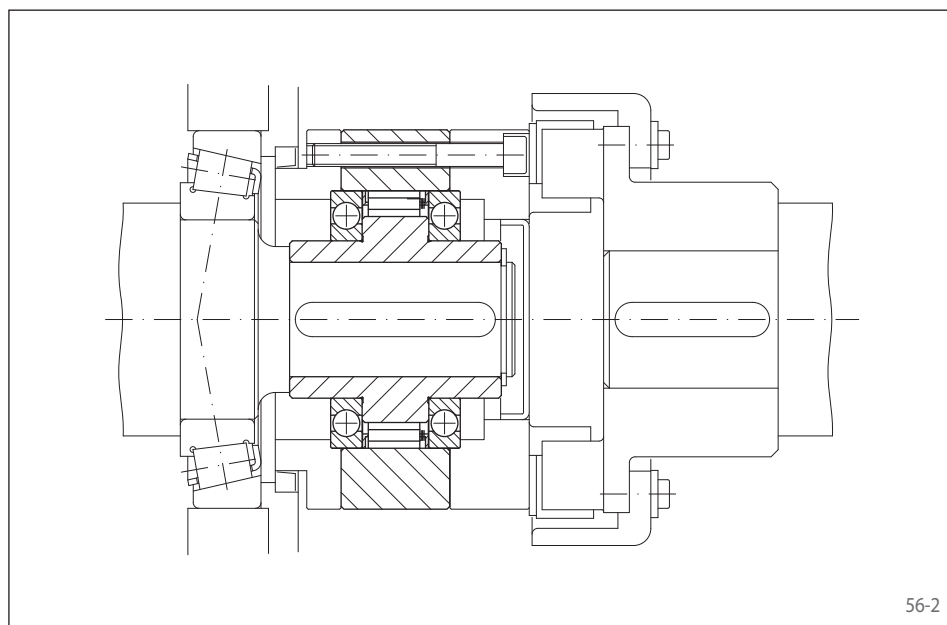

Application example

Basic Freewheel FBO 127 SF as an overrunning clutch between the creep drive and the main drive of a cement mixer. In the case of creep operation, the outer ring is driven by the shaft coupling. The freewheel works in driving operation and drives the unit at a low speed via the main gearbox. In normal operation (freewheeling operation), the inner ring overruns and the creep drive is automatically disengaged. The freewheel is connected to the oil lubrication of the main gearbox and does not require any special maintenance. The arrangement of the seals between the freewheel and the main gearbox is advantageous. In normal operation (freewheeling operation), this is at a standstill and hence generates no additional friction-related temperature rise.

Mounting

The customer connecting parts are centered on the ball bearing external diameter F and assembled via the outer ring.

The tolerance of the shaft must be ISO h6 or j6 and the tolerance of the pilot diameter F of the connecting part must be ISO H7 or J7. The centering depth C must be observed.

Lubrication

An oil lubrication of the specified quality must be provided.

Example for ordering

Freewheel size FBO 72, type with sprag lift-off X and 40 mm bore:

- FBO 72 DX, d = 40 mm

for assembly with connecting parts
with sprags, available in four types

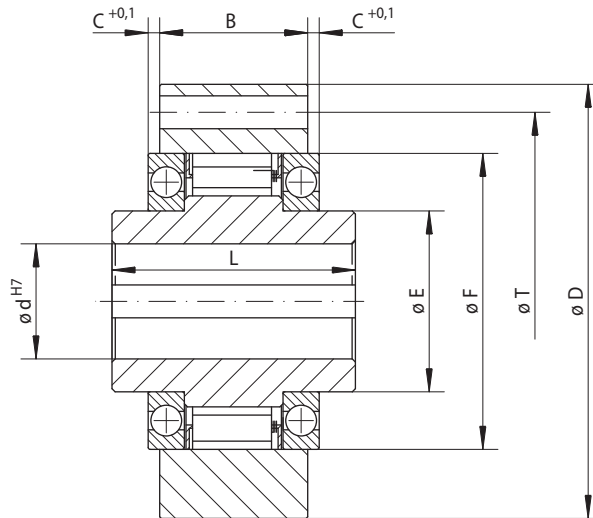

57-1

	Standard type For universal use	Type with RIDUVIT® For extended service life with coated sprags	Type with sprag lift-off X For extended service life using sprag lift-off at high speed rotating inner ring	Type with sprag lift-off Z For extended service life using sprag lift-off at high speed rotating outer ring
Indexing Freewheel				
Overrunning Clutch				
Backstop				

Freewheel Size	Type	Nominal torque M _N Nm	Max. speed		Type	Nominal torque M _N Nm	Max. speed		Type	Nominal torque M _N Nm	Sprag lift-off at inner ring speed min ⁻¹	Max. speed		Type	Nominal torque M _N Nm	Outer ring freewheels/overruns min ⁻¹	Außenring läuft frei/überholt min ⁻¹	Max. speed	
			Inner ring freewheels/overruns min ⁻¹	Outer ring freewheels/overruns min ⁻¹			Inner ring freewheels/overruns min ⁻¹	Outer ring drives min ⁻¹				Inner ring drives min ⁻¹							
FBO 37	SF	200	2 500	2 600	SFT	200	2 500	2 600						CZ	110	850	3 000	340	
FBO 44	SF	320	1 900	2 200	SFT	320	1 900	2 200	DX	130	860	1 900	344	CZ	180	800	2 600	320	
FBO 57	SF	630	1 400	1 750	SFT	630	1 400	1 750	DX	460	750	1 400	300	LZ	430	1 400	2 100	560	
FBO 72	SF	1 250	1 120	1 600	SFT	1 250	1 120	1 600	DX	720	700	1 150	280	LZ	760	1 220	1 800	488	
FBO 82	SF	1 800	1 025	1 450	SFT	1 800	1 025	1 450	DX	1 000	670	1 050	268	SFZ	1 700	1 450	1 600	580	
FBO 107	SF	2 500	880	1 250	SFT	2 500	880	1 250	DX	1 500	610	900	244	SFZ	2 500	1 300	1 350	520	
FBO 127	SF	5 000	800	1 150	SFT	5 000	800	1 150	SX	3 400	380	800	152	SFZ	5 000	1 200	1 200	480	
FBO 140	SF	10 000	750	1 100	SFT	10 000	750	1 100	SX	7 500	320	750	128	SFZ	10 000	950	1 150	380	
FBO 200	SF	20 000	630	900	SFT	20 000	630	900	SX	23 000	240	630	96	SFZ	20 000	680	900	272	
FBO 270	SF	40 000	510	750	SFT	40 000	510	750	SX	40 000	210	510	84	SFZ	37 500	600	750	240	
FBO 340	SF	80 000	460	630	SFT	80 000	460	630											
FBO 440	SF	160 000	400	550	SFT	160 000	400	550											

The maximum transmissible torque is 2 times the specified nominal torque. See page 14 for determination of selection torque.
The specified maximum speeds apply for installation conditions as given with Complete Freewheels. Knowing the actual installation conditions higher speeds can be permitted under some circumstances.

Freewheel Size	Bore d		B mm	C1*** mm	C2*** mm	C3*** mm	D mm	E mm	F mm	G	L mm	T mm	Z**	Weight kg
	Standard mm	max. mm												
FBO 37	20	22*	25	3,7		4,3	85	30	55	M 6	48	70	6	0,9
FBO 44	25*	25*	25	3,7	4,7	4,4	95	35	62	M 6	50	80	8	1,3
FBO 57	30	32*	30	4,2	7,7	7,4	110	45	75	M 8	65	95	8	1,9
FBO 72	40	42*	38	3,7	4,9	4,4	132	55	90	M 8	74	115	12	3,5
FBO 82	50*	50*	40	6,6	6,6	6,6	145	65	100	M 10	75	125	12	4,0
FBO 107	60	65*	45	8,1	8,1	8,1	170	80	125	M 10	90	150	12	7,7
FBO 127	70	75*	68	6,9	7,9	6,9	200	95	145	M 12	112	180	12	13,3
FBO 140	90	95*	68	19,1	20,1	19,1	250	120	180	M 16	150	225	12	31,5
FBO 200	120	120	85	14,1	15,1	14,1	320	160	240	M 16	160	288	16	46,5
FBO 270	140	150	100	22,5	22,5	22,5	420	200	310	M 20	212	370	18	105,0
FBO 340	180	240	125	25,6			497	300	380	M 20	265	450	24	190,0
FBO 440	220	300	150	34,1			627	380	480	M 30	315	560	24	360,0

Freewheels with bore diameters highlighted blue in the table are available with short delivery times.

Keyway according to DIN 6885, page 1 • Tolerance of keyway width JS10.

* Keyway according to DIN 6885, page 3 • Tolerance of keyway width JS10.

** Z = Number of fastening holes for screws G (DIN EN ISO 4762) on pitch circle T.

*** C1 = Centering depth of connecting parts for standard type and type with RIDUVIT®.

C2 = Centering depth of connecting parts for type with sprag lift-off X.

C3 = Centering depth of connecting parts for type with sprag lift-off Z.

Basic Freewheels FGR ... R

for assembly with connecting parts
with rollers

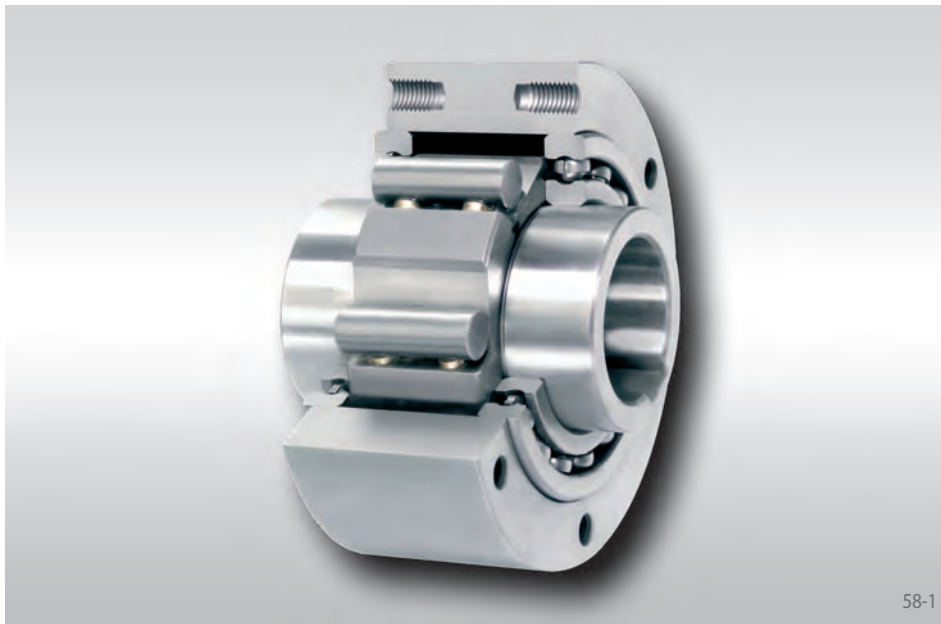

Application as

- ▶ Backstop
- ▶ Overrunning Clutch
- ▶ Indexing Freewheel

Features

Basic Freewheels FGR ... R are roller freewheels with ball bearings to be assembled with customer connecting parts. The freewheels are particularly suitable for installation in housings with oil lubrication and seals.

Nominal torques up to 68 000 Nm.

Bores up to 150 mm.

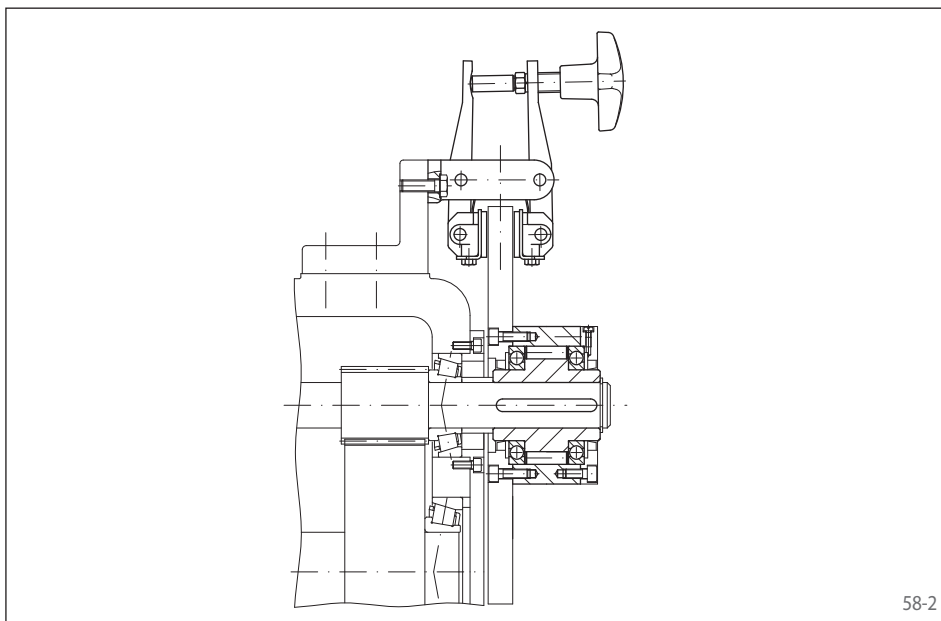

Application example

Basic Freewheel FGR 25 R as a backstop on a reduction gear in the drive of an inclined conveyor of an assembly train. When the unit stops, the conveyor belt must be held securely so that it does not run backwards by the weight of the assembly parts. A brake disk is fitted to the outer ring of the freewheel alongside a manually operated RINGSPANN brake calliper. The back-driving torque is maintained by the freewheel and the closed brake. During set-up it must be possible to move the installation in both directions of rotation. To do this, the brake calliper is opened manually.

for assembly with connecting parts
with rollers

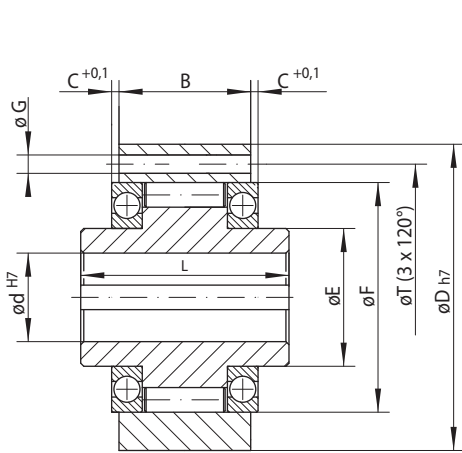

Size FGR 12

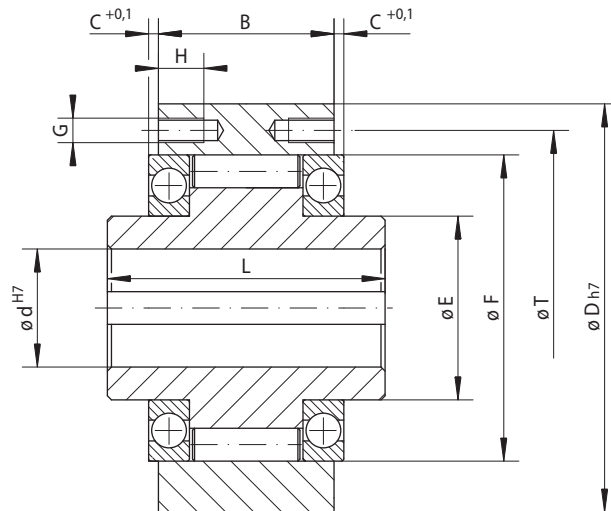

59-1 Size FGR 15 to FGR 150

59-2

Indexing Freewheel Overrunning Clutch Backstop	Standard type For universal use	Dimensions

Freewheel Size	Type	Nominal torque M_N Nm	Max. speed		Bore d mm	B mm	C mm	D mm	E mm	F mm	G** mm	H mm	L mm	T mm	Z**	Weight kg
			Inner ring freewheels/overruns min^{-1}	Outer ring freewheels/overruns min^{-1}												
FGR 12	R	55	2500	5400	12	20	3,5	62	20	42	5,5 mm	-	42	51	3	0,5
FGR 15	R	130	2200	4800	15	28	2,0	68	25	47	M 5	8	52	56	3	0,8
FGR 20	R	180	1900	4100	20	34	2,4	75	30	55	M 5	8	57	64	4	1,0
FGR 25	R	290	1550	3350	25	35	2,4	90	40	68	M 6	10	60	78	4	1,5
FGR 30	R	500	1400	3050	30	43	2,4	100	45	75	M 6	10	68	87	6	2,2
FGR 35	R	730	1300	2850	35	45	2,9	110	50	80	M 6	12	74	96	6	3,0
FGR 40	R	1 000	1 150	2500	40	53	2,9	125	55	90	M 8	14	86	108	6	4,6
FGR 45	R	1 150	1 100	2400	45	53	2,9	130	60	95	M 8	14	86	112	8	4,7
FGR 50	R	2 100	950	2050	50	64	3,9	150	70	110	M 8	14	94	132	8	7,2
FGR 55	R	2 600	900	1900	55	66	2,9	160	75	115	M 10	16	104	138	8	8,6
FGR 60	R	3 500	800	1800	60	78	5,4	170	80	125	M 10	16	114	150	10	10,5
FGR 70	R	6 000	700	1600	70	95	6,4	190	90	140	M 10	16	134	165	10	13,4
FGR 80	R	6 800	600	1400	80	100	3,9	210	105	160	M 10	16	144	185	10	18,2
FGR 90	R	11 000	500	1300	90	115	4,9	230	120	180	M 12	20	158	206	10	28,0
FGR 100	R	20 000	350	1000	100	120	5,4	270	140	210	M 16	24	182	240	10	43,0
FGR 130	R	31 000	250	900	130	152	7,9	310	160	240	M 16	24	212	278	12	66,0
FGR 150	R	68 000	200	700	150	180	6,9	400	200	310	M 20	32	246	360	12	136,0

■ Freewheels with bore diameters highlighted blue in the table are available with short delivery times.
The maximum transmissible torque is 2 times the specified nominal torque. See page 14 for determination of selection torque.
Keyway according to DIN 6885, page 1 • Tolerance of keyway width JS10.
** Z = Number of tapped holes or mounting holes G on pitch circle T.

Mounting

The customer connecting parts are centered on the ball bearing external diameter F and assembled via the outer ring.

The tolerance of the shaft must be ISO h6 or j6 and the tolerance of the pilot diameter F of the connecting part must be ISO H7 or J7. The centering depth C must be observed.

Lubrication

An oil lubrication of the specified quality must be provided. Two flat seals are supplied for sealing between the faces of the outer ring and the connecting parts.

Example for ordering

Freewheel size FGR 35, standard type:

- FGR 35 R

for bolting to the face
with sprag lift-off X



Application as

- ▶ Backstop
- ▶ Overrunning Clutch

For application as backstop in installations with high speeds in freewheeling operation.

For application as overrunning clutch in installations with low speeds in driving operation.

Features

Integrated Freewheels FXM are sprag free-wheels without bearing support and with sprag lift-off X.

The sprag lift-off X ensures a wear-free freewheeling operation when the inner ring rotates at high speed.

Nominal torques up to 1 230 000 Nm.

Bores up to 560 mm. A multitude of standardized bore diameters are available with short delivery times.

Sprag lift-off X

Integrated Freewheels FXM are equipped with sprag lift-off X. The sprag lift-off X is used for backstops and overrunning clutches, provided that in freewheeling operation the inner ring is rotating at high speed and providing with overrunning clutches that the driving operation is conducted at low speed. In freewheeling operation, the centrifugal force F_C causes the sprag to lift off from the outer track. In this operating state, the freewheel works wear-free, i.e. with unlimited service life.

Figure 60-2 shows a freewheel with sprag lift-off X in freewheeling operation. The sprags, which are supported in a cage connected with the inner ring, rotate with the inner ring. The centrifugal force F_C that is applied in the center of gravity S of the sprag turns the sprag counterclockwise and rests against the support ring of the cage. This results in the gap a between the sprag and the outer track; the freewheel works without contact. If the inner ring speed decreases to such an extent that the effect of

the centrifugal force on the sprag is less than that of the spring force F_F , the sprag again rests on the outer ring and the freewheel is ready to lock (figure 60-3). If used as an overrunning clutch, the driving speed must not exceed 40% of the lift-off speed.

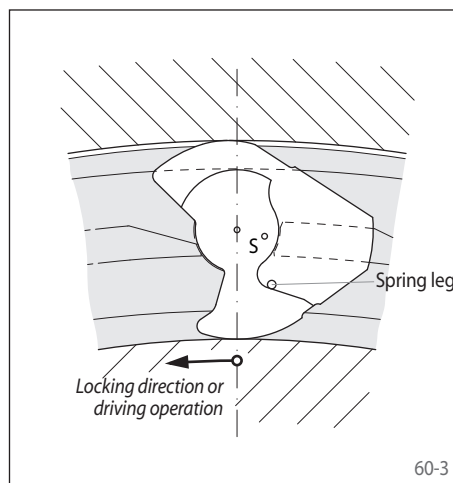
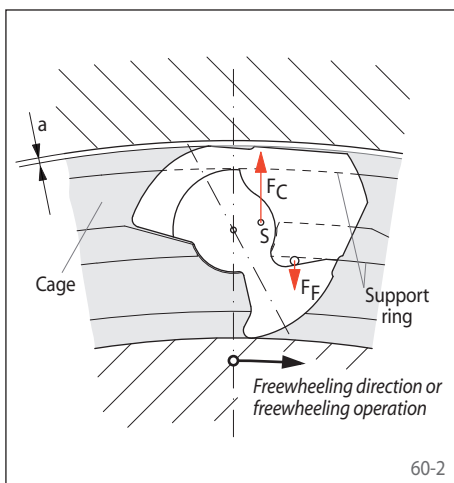

for bolting to the face
with sprag lift-off X

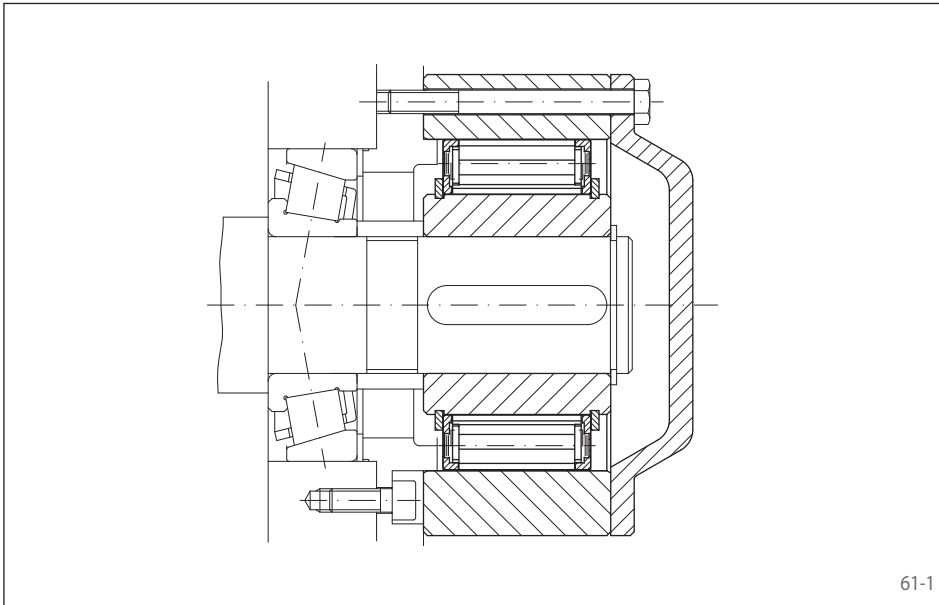

61-1

Application example

Integrated Freewheel FXM 170 - 63 MX with end cover as backstop fitted to the end of the first intermediate shaft of a spur gearbox in the drive of an inclined conveyor belt. In the case of a motor stop, the conveyor belt must be held securely so that the conveyor goods do not pull the belt backwards and possibly cause serious damage. Due to the high shaft speeds in normal operation (freewheeling operation), the sprag lift-off X ensures a contactless and hence wear-free continuous operation.

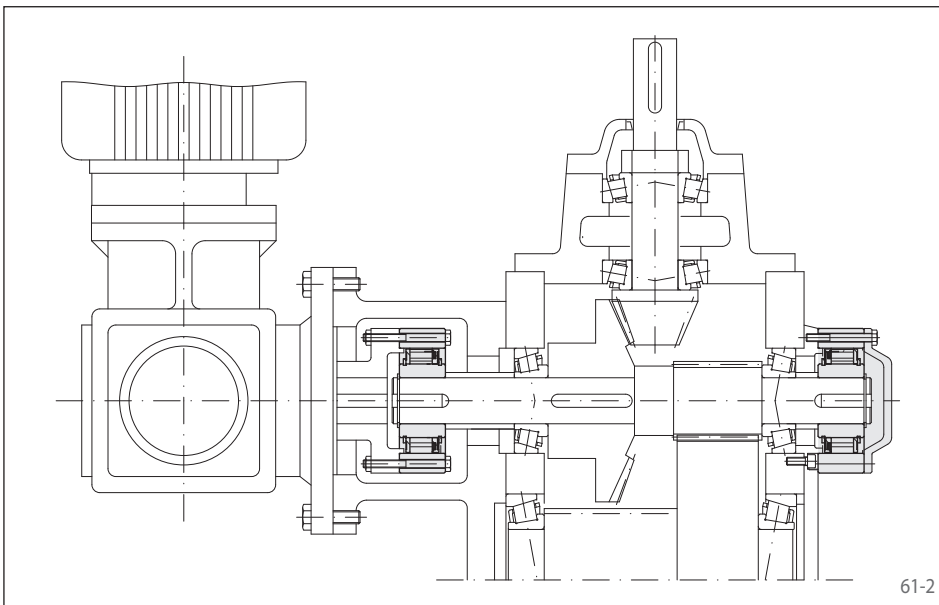

61-2

Application example

Two Integrated Freewheels FXM 120 – 50 MX in the gearbox unit of a vertical bucket conveyor. Alongside the main drive, the bucket conveyor has a creep drive, which can be moved at a low speed if maintenance work needs to be carried out. The freewheel arranged between the creep drive and the main drive works as an overrun clutch. When the creep drive operates, the freewheel is in driving operation. In normal operation, when driving via the main drive, the inner ring of the freewheel overruns at high speed and automatically disengages the creep drive. The second freewheel that is arranged on the end of the first intermediate shaft of the main gearbox, works as a backstop and prevents the bucket conveyor from running back when the unit is at a standstill.

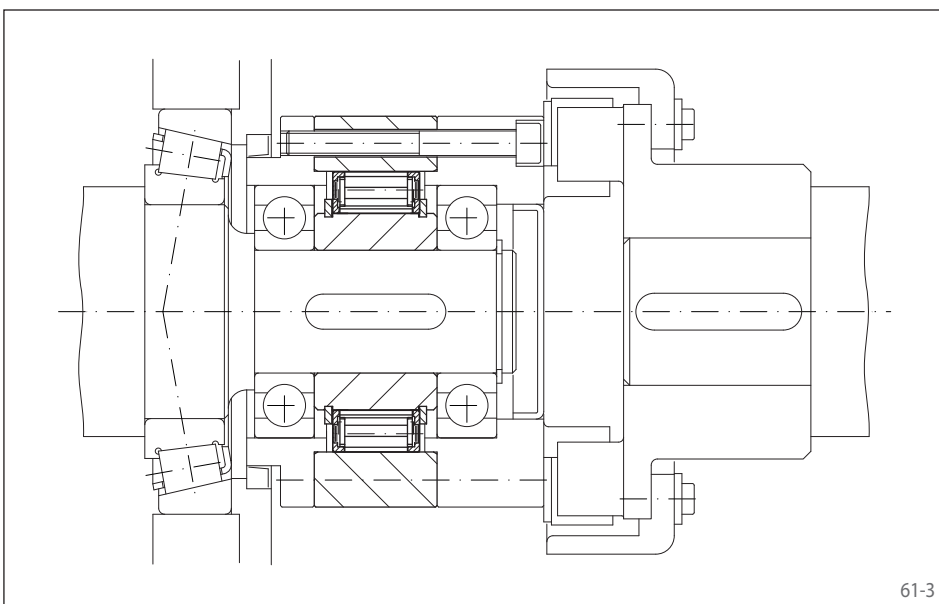

61-3

Application example

Integrated Freewheel FXM 76-25 NX as an overrun clutch between the creep drive and the main drive of a cement mixer. When the creep drive operates, the outer ring is driven by the shaft coupling. The freewheel works in driving operation and drives the unit at a low speed via the main gearbox. In normal operation (freewheeling operation), the inner ring overruns at high speed and the creep drive is automatically disengaged. With the high shaft speed, the type sprag lift-off X is used; the sprags work in freewheeling operation without contact and hence are wear-free. The arrangement of the seals between the freewheel and the main gearbox is advantageous. In freewheeling operation, this is at a standstill and hence generates no additional friction-related temperature rise.

for bolting to the face
with sprag lift-off X

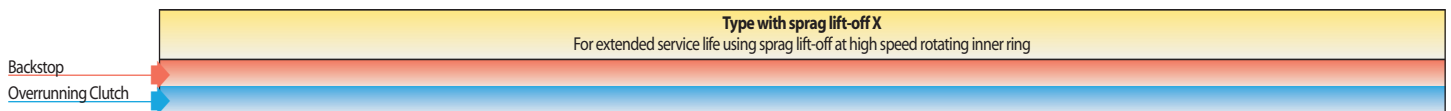
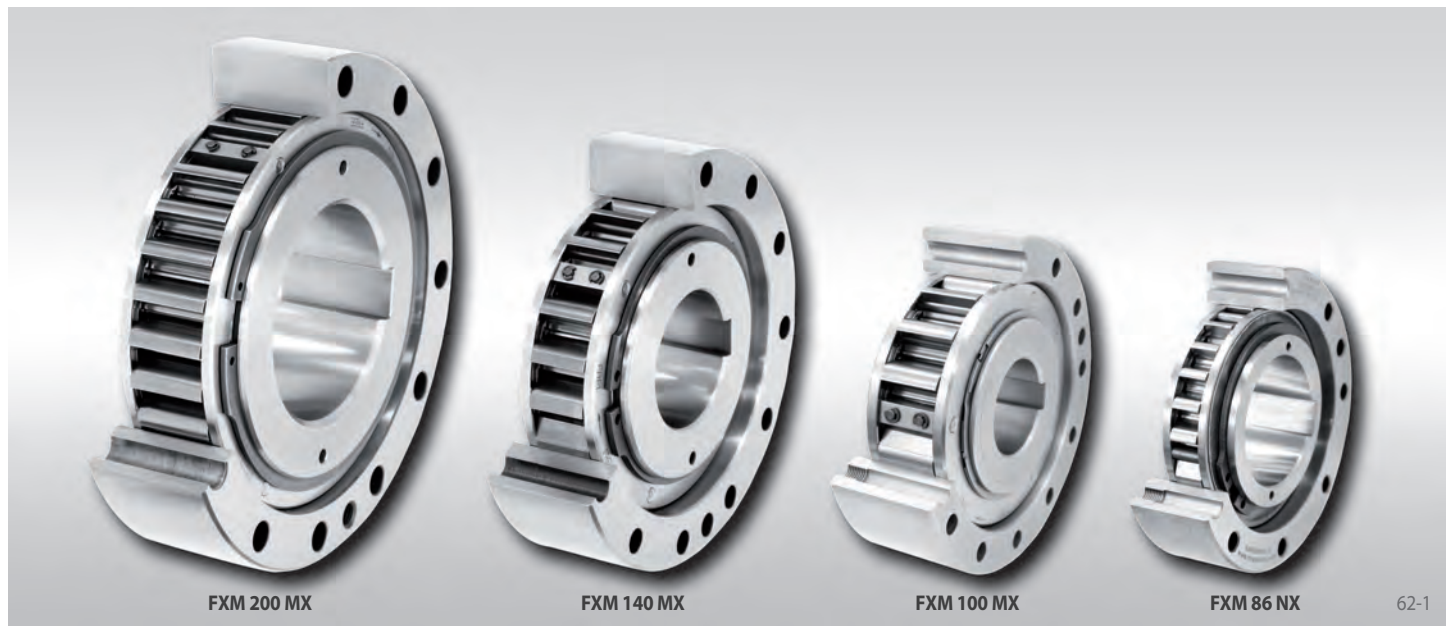

Freewheel Size	Type	Theoretical nominal torque		Nominal torque at existing run out (T.I.R.)						Sprag lift-off at inner ring speed min ⁻¹	Max. speed	
		0 A Nm	0,1 A Nm	0,2 A Nm	0,3 A Nm	0,4 A Nm	0,5 A Nm	Inner ring freewheels/ overruns min ⁻¹	Outer ring drives min ⁻¹			
FXM 31 - 17	NX	110	110	105	100				890	5 000	356	
FXM 38 - 17	NX	180	170	160	150				860	5 000	344	
FXM 46 - 25	NX	460	450	440	430				820	5 000	328	
FXM 51 - 25	NX	560	550	540	530				750	5 000	300	
FXM 56 - 25	NX	660	650	640	630				730	5 000	292	
FXM 61 - 19	NX	520	500	480	460				750	5 000	300	
FXM 66 - 25	NX	950	930	910	890				700	5 000	280	
FXM 76 - 25	NX	1 200	1 170	1 140	1 110				670	5 000	268	
FXM 86 - 25	NX	1 600	1 550	1 500	1 450				630	5 000	252	
FXM 101 - 25	NX	2 100	2 050	2 000	1 950				610	5 000	244	
FXM 85 - 40	MX	2 500	2 500	2 450	2 450	2 450	2 450		430	6 000	172	
FXM 100 - 40	MX	3 700	3 600	3 600	3 500	3 500	3 500		400	4 500	160	
FXM 120 - 50	MX	7 700	7 600	7 500	7 300	7 300	7 300		320	4 000	128	
FXM 140 - 50	MX	10 100	10 000	9 800	9 600	9 500	9 500		320	3 000	128	
FXM 170 - 63	MX	20 500	20 500	20 000	19 500	19 000	19 000		250	2 700	100	
FXM 200 - 63	MX	31 000	30 500	30 000	26 500	23 000	20 500		240	2 100	96	

The maximum transmissible torque is 2 times the specified nominal torque. See page 14 for determination of selection torque.
The theoretical nominal torque applies only for ideal concentricity between the inner and outer ring. In practice, the concentricity is affected by the bearing play and centering errors of the neighbouring parts. Then the nominal torques specified in the table apply, whilst taking into consideration the existing run out (T.I.R.).
Higher speeds upon request.

Mounting

Integrated Freewheels FXM are without bearing support. Concentric alignment of inner and outer ring must be provided by the customer. The permissible run out (T.I.R.) must be observed.

The Integrated Freewheel FXM is centered via the outer track F on the customer attachment part and bolted to this (refer to figure 63-1). The tolerance of the pilot diameter of the attachment part must be ISO h6 or h7.

The tolerance of the shaft must be ISO h6 or j6.

For fitting to shaft ends, end covers can be supplied upon request (refer to figure 63-3).

for bolting to the face
with sprag lift-off X

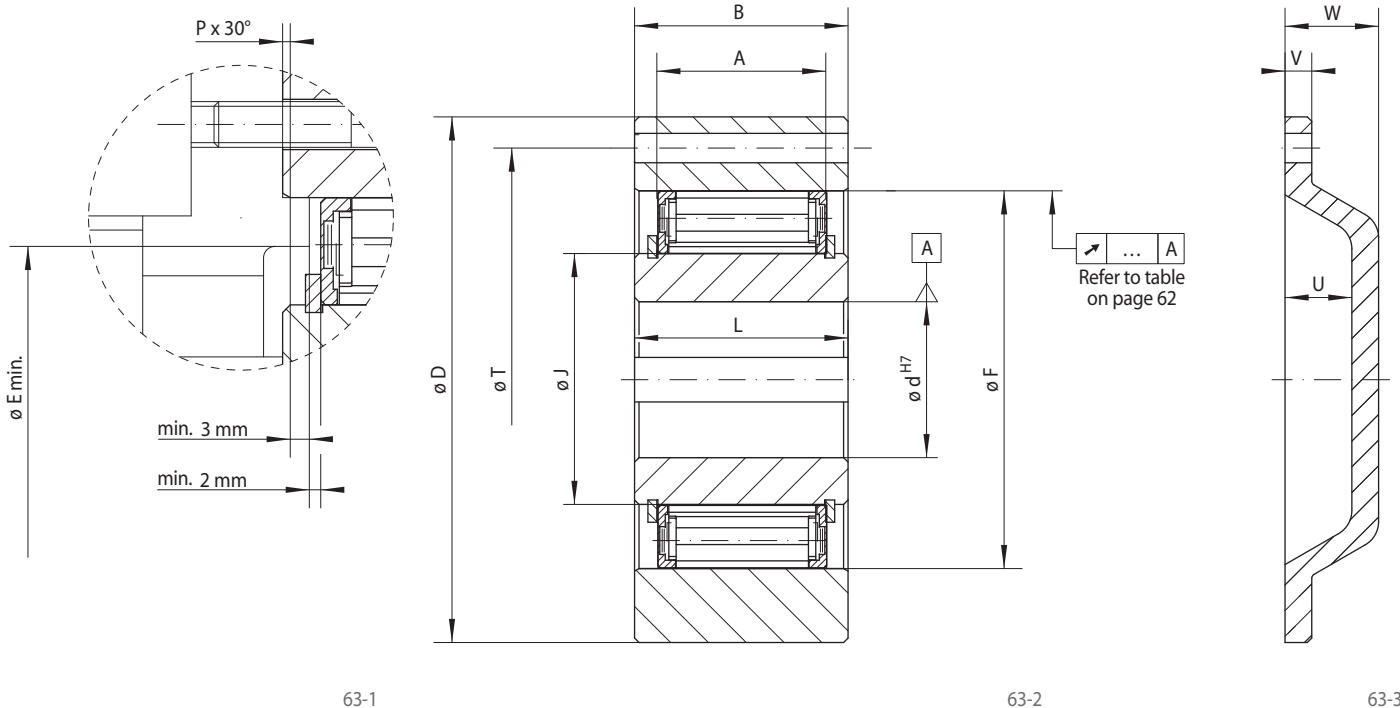

Freewheel Size	Type	Bore d			A	B	D	E min.	F	G**	J	L	P	T	U	V	W	Z**	Weight
		Standard	mm	max. mm															
FXM 31 -17	NX	20*		20*	17	25	85	41	55	M 6	31	24	1,0	70	15	6	21	6	0,8
FXM 38 -17	NX	25*		25*	17	25	90	48	62	M 6	38	24	1,0	75	15	6	21	6	0,9
FXM 46 -25	NX	30		30	25	35	95	56	70	M 6	46	35	1,0	82	15	6	21	6	1,3
FXM 51 -25	NX	35		36	25	35	105	62	75	M 6	51	35	1,0	90	15	6	21	6	1,7
FXM 56 -25	NX	35	40	40	25	35	110	66	80	M 6	56	35	1,0	96	15	6	21	8	1,8
FXM 61 -19	NX	35	40	45*	19	27	120	74	85	M 8	61	25	1,0	105	15	6	21	6	1,8
FXM 66 -25	NX	40	45	48	25	35	132	82	90	M 8	66	35	1,0	115	15	8	23	8	2,8
FXM 76 -25	NX	50	55	60*	25	35	140	92	100	M 8	76	35	1,0	125	15	8	23	8	3,1
FXM 86 -25	NX	50	60	70	25	40	150	102	110	M 8	86	40	1,0	132	15	8	23	8	4,2
FXM 101 -25	NX	75		80*	25	50	175	117	125	M 10	101	50	1,0	155	20	8	28	8	6,9
FXM 85 -40	MX	60		65	40	50	175	102	125	M 10	85	60	1,0	155	20	8	28	8	7,4
FXM 100 -40	MX	70		80*	40	50	190	130	140	M 10	100	60	1,5	165	25	10	35	12	8,8
FXM 120 -50	MX	80		95	50	60	210	150	160	M 10	120	70	1,5	185	25	10	35	12	12,7
FXM 140 -50	MX	90		110	50	70	245	170	180	M 12	140	70	2,0	218	25	12	35	12	19,8
FXM 170 -63	MX	100		130	63	80	290	200	210	M 16	170	80	2,0	258	28	12	38	12	33,0
FXM 200 -63	MX	120		155	63	80	310	230	240	M 16	200	80	2,0	278	32	12	42	12	32,0

Freewheels with bore diameters highlighted blue in the table are available with short delivery times.

Keyway according to DIN 6885, page 1 • Tolerance of keyway width JS10.

* Keyway according to DIN 6885, page 3 • Tolerance of keyway width JS10.

** Z = Number of fastening holes for screws G on pitch circle T.

Lubrication

At speeds in excess of the sprag lift-off speed, no special lubrication is required; the freewheel functions maintenance-free.

When operating below the sprag lift-off speed, an oil lubrication of the specified oil quality must be provided.

Example for ordering

Freewheel size FXM 140 - 50, type with sprag lift-off X and 90 mm bore and end cover:

- FXM 140 - 50 MX, d = 90 mm, with end cover

Integrated Freewheels FXM ... LX

for bolting to the face
with sprag lift-off X



Type with sprag lift-off X
For extended service life using sprag lift-off at high speed rotating inner ring

Backstop →

Overrunning Clutch →

Freewheel Size	Type	Theoretical nominal torque Nm	Nominal torque at existing run out (T.I.R.)						Sprag lift-off at inner ring speed min ⁻¹	Max. speed	
			0,1 A	0,2 A	0,3 A	0,4 A	0,5 A	0,8 A		Inner ring freewheels/overruns min ⁻¹	Outer ring drives min ⁻¹
FXM 240 - 63	LX	36 500	36 000	35 500	35 500	35 000	34 500	34 000	220	3 000	88
FXM 240 - 96	LX	59 000	58 500	58 500	57 500	57 000	56 500	56 000	220	2 500	88
FXM 2.240 - 70	LX	81 000	80 500	80 000	79 500	78 500	77 500	77 000	220	2 500	88
FXM 2.240 - 96	LX	117 500	116 500	116 000	114 500	113 500	112 500	111 500	220	2 500	88
FXM 260 - 63	LX	44 500	44 000	44 000	43 500	43 000	42 500	41 500	210	2 250	84
FXM 290 - 70	LX	65 000	64 500	64 000	63 500	62 500	62 000	60 000	200	2 250	80
FXM 290 - 96	LX	95 500	95 000	94 500	93 500	92 500	91 500	84 500	200	2 250	80
FXM 2.290 - 70	LX	125 500	124 500	123 500	122 500	121 000	119 500	117 000	200	2 250	80
FXM 2.290 - 96	LX	183 000	181 500	180 000	178 500	176 500	174 500	171 000	200	2 250	80
FXM 310 - 70	LX	76 000	75 000	74 500	74 000	73 000	72 500	70 000	195	2 250	78
FXM 310 - 96	LX	112 000	111 000	110 500	109 500	108 000	107 000	99 000	195	2 100	78
FXM 320 - 70	LX	81 000	80 500	80 000	79 500	78 500	78 000	65 500	195	2 000	78
FXM 320 - 96	LX	114 000	113 500	112 500	111 500	110 000	109 000	105 500	195	2 000	78
FXM 2.320 - 70	LX	158 000	156 500	155 500	154 000	152 500	151 000	143 000	195	2 000	78
FXM 2.320 - 96	LX	225 000	223 500	221 500	220 000	217 500	215 000	209 000	195	2 000	78
FXM 360 - 100	LX	156 000	155 000	154 000	152 500	144 000	134 500	108 000	180	1 800	72
FXM 2.360 - 73	LX	208 000	206 500	204 500	203 000	201 000	199 000	163 000	180	1 800	72
FXM 2.360 - 100	LX	294 500	292 500	290 000	287 500	284 500	281 500	258 500	180	1 800	72
FXM 410 - 100	LX	194 500	193 500	192 000	190 000	188 500	179 500	145 000	170	1 500	68
FXM 2.410 - 73	LX	263 000	261 000	259 000	257 000	254 500	252 000	209 500	170	1 500	68
FXM 2.410 - 100	LX	389 500	387 000	384 000	380 500	377 000	359 500	289 500	170	1 500	68
FXM 500 - 100	LX	290 000	287 500	285 500	283 000	272 000	255 000	202 000	150	1 000	60
FXM 2.500 - 100	LX	578 000	574 000	570 000	566 000	547 000	508 000	407 000	150	1 000	60
FXM 620 - 105	LX	444 500	441 500	438 500	427 000	400 000	374 000	300 000	135	1 000	54
FXM 2.620 - 105	LX	888 000	882 000	876 000	860 000	807 000	754 000	603 000	135	1 000	54
FXM 750 - 105	LX	605 000	601 000	596 000	591 000	586 000	579 000	504 000	125	800	50
FXM 2.750 - 105	LX	1 230 000	1 220 000	1 210 000	1 200 000	1 190 000	1 179 000	958 000	125	800	50

The maximum transmissible torque is 2 times the specified nominal torque. See page 14 for determination of selection torque.
The theoretical nominal torque applies only for ideal concentricity between the inner and outer ring. In practice, the concentricity is affected by the bearing play and centering errors of the neighbouring parts. Then the nominal torques specified in the table apply, whilst taking into consideration the existing run out (T.I.R.).
Higher speeds upon request.

Mounting

Integrated Freewheels FXM are without bearing support. Concentric alignment of inner and outer ring must be provided by the customer. The permissible run out (T.I.R.) must be observed.

The Integrated Freewheel FXM is centered via the outer track F on the customer attachment part and bolted to this (refer to figure 65-1). The tolerance of the pilot diameter of the attachment part must be ISO h6 or h7.

The tolerance of the shaft must be ISO h6 or j6.

for bolting to the face
with sprag lift-off X

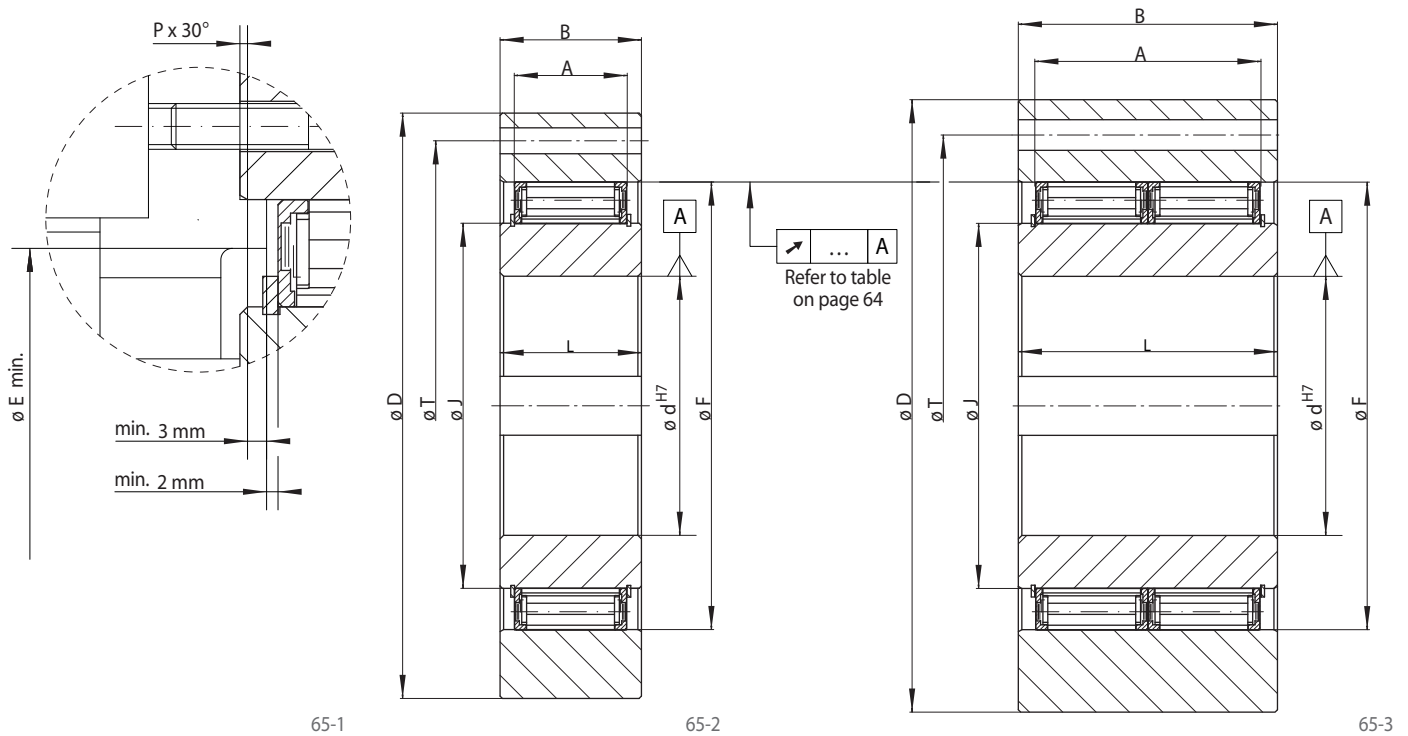

Freewheel Size	Type	Bore d max. mm	A mm	B mm	D mm	E min. mm	F mm	G*	J mm	L mm	P mm	T mm	Z*	Weight kg
FXM 240 - 63	LX	185	63	80	400	280	310	M 20	240	90	2,0	360	12	60
FXM 240 - 96	LX	185	96	125	420	280	310	M 24	240	120	2,0	370	16	95
FXM 2.240 - 70	LX	185	140	160	412	280	310	M 20	240	160	2,0	360	24	120
FXM 2.240 - 96	LX	185	192	240	425	280	310	M 24	240	240	2,0	370	24	200
FXM 260 - 63	LX	205	63	80	430	300	330	M 20	260	105	2,0	380	16	75
FXM 290 - 70	LX	230	70	80	460	330	360	M 20	290	105	2,0	410	16	90
FXM 290 - 96	LX	230	96	110	460	330	360	M 20	290	120	2,0	410	16	91
FXM 2.290 - 70	LX	230	140	160	480	330	360	M 24	290	160	2,0	410	18	170
FXM 2.290 - 96	LX	230	192	240	490	330	360	M 30	290	240	2,0	425	20	260
FXM 310 - 70	LX	240	70	125	497	360	380	M 20	310	110	3,0	450	24	135
FXM 310 - 96	LX	240	96	125	497	360	380	M 20	310	120	3,0	450	24	145
FXM 320 - 70	LX	250	70	80	490	360	390	M 24	320	105	3,0	440	16	105
FXM 320 - 96	LX	250	96	120	520	360	390	M 24	320	120	3,0	440	16	150
FXM 2.320 - 70	LX	250	140	180	505	360	390	M 24	320	180	3,0	440	24	200
FXM 2.320 - 96	LX	250	192	240	530	360	390	M 30	320	240	3,0	460	24	310
FXM 360 - 100	LX	280	100	120	540	400	430	M 24	360	125	3,0	500	24	170
FXM 2.360 - 73	LX	280	146	210	550	400	430	M 24	360	210	3,0	500	24	270
FXM 2.360 - 100	LX	280	200	250	580	400	430	M 30	360	250	3,0	500	24	380
FXM 410 - 100	LX	300	100	120	630	460	480	M 24	410	125	3,0	560	24	245
FXM 2.410 - 73	LX	300	146	210	630	460	480	M 24	410	210	3,0	560	24	400
FXM 2.410 - 100	LX	300	200	220	630	460	480	M 30	410	220	3,0	560	24	440
FXM 500 - 100	LX	360	100	130	780	550	570	M 30	500	130	3,0	680	24	310
FXM 2.500 - 100	LX	360	200	230	780	550	570	M 30	500	230	3,0	680	24	560
FXM 620 - 105	LX	460	105	140	980	670	690	M 30	620	140	3,0	840	24	570
FXM 2.620 - 105	LX	460	210	240	980	670	690	M 36	620	240	3,0	840	24	990
FXM 750 - 105	LX	560	105	150	1 350	800	820	M 42	750	150	3,0	1 000	24	1 330
FXM 2.750 - 105	LX	560	210	250	1 350	800	820	M 42	750	250	3,0	1 000	24	2 620

Keyway according to DIN 6885, page 1 • Tolerance of keyway width JS10.

* Z = Number of fastening holes for screws G on pitch circle T.

Lubrication

At speeds in excess of the sprag lift-off speed, no special lubrication is required; the freewheel functions maintenance-free.

When operating below the sprag lift-off speed, an oil lubrication of the specified oil quality must be provided.

Example for ordering

Freewheel size FXM 240 - 63, type with sprag lift-off X and 185 mm bore:

- FXM 240 - 63 LX, d = 185 mm

Integrated Freewheels FON

for bolting to the face
with sprags, available in three types

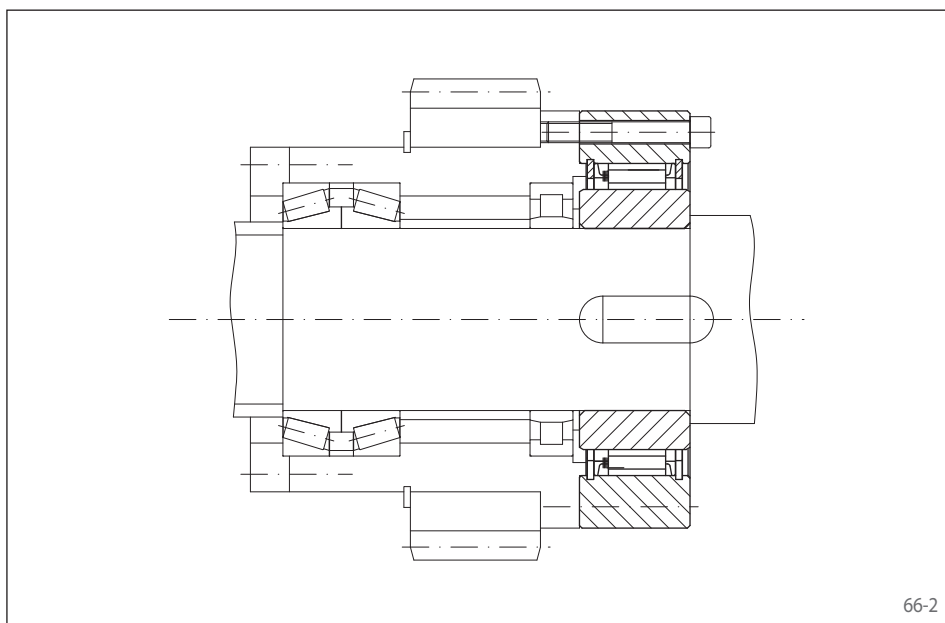

Application as

- ▶ Backstop
- ▶ Overrunning Clutch
- ▶ Indexing Freewheel

Features

Integrated Freewheels FON are sprag freewheels without bearing support.

In addition to the standard type, two other types are available for extended service life and indexing accuracy.

Nominal torques up to 25 000 Nm.

Bores up to 155 mm. A multitude of standardized bore diameters are available with short delivery times.

Application example

Integrated Freewheel FON 57 SFT as an overrunning clutch, arranged on the main drive shaft of a packaging machine. The outer ring is connected to a creep drive by means of a gear wheel. This drive is used during set-up. In this operating state, the freewheel works in driving operation and drives the machine at a very low speed via the main shaft. In normal operation (freewheeling operation), the inner ring overruns and the creep drive is automatically disengaged. The RIDUVIT® sprags give the freewheel an extended service life.

Mounting

Integrated Freewheels FON are without bearing support. Concentric alignment of inner and outer ring must be provided by the customer. The permissible run out (T.I.R.) must be observed.

The Integrated Freewheel FON is centered via the outer track F on the customer attachment part and bolted to this. The tolerance of the pilot diameter of the attachment part must be ISO h6.

The tolerance of the shaft must be ISO h6 or j6.

Lubrication

In the case of standard type and type with RIDUVIT®, an oil lubrication of the specified oil quality must be provided.

In the case of the type with sprag lift-off Z, at speeds in excess of the sprag lift-off speed, no special lubrication is required; the freewheel functions maintenance-free. When operating below the sprag lift-off speed, an oil lubrication of the specified oil quality must be provided.

Example for ordering

Freewheel size FON 72, type with RIDUVIT® and 45 mm bore:

- FON 72 SFT, d = 45 mm

for bolting to the face
with sprags, available in three types

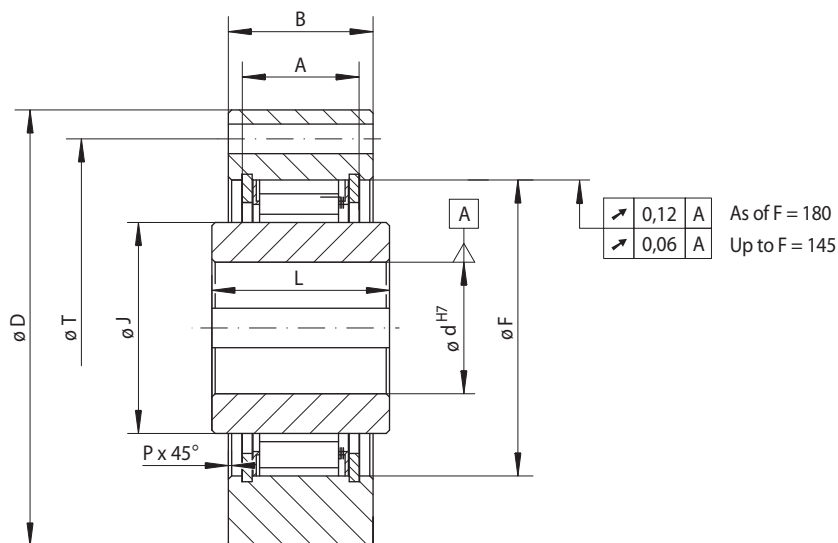

67-1

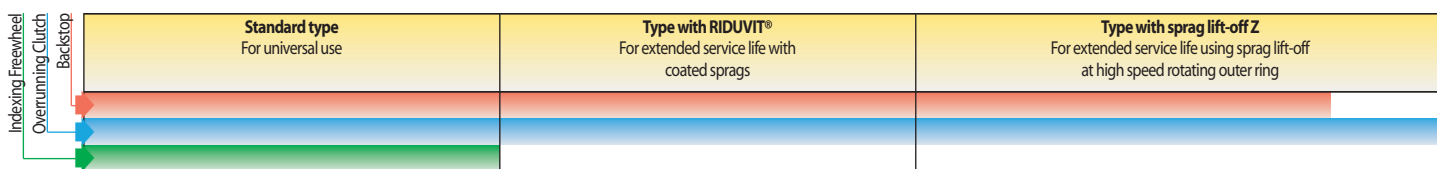

Freewheel Size	Type	Nominal torque M_N Nm	Max. speed		Type	Nominal torque M_N Nm	Max. speed		Type	Nominal torque M_N Nm	Sprag lift-off at outer ring speed min^{-1}	Max. speed	
			Inner ring freewheels/overruns min^{-1}	Outer ring freewheels/overruns min^{-1}			Inner ring freewheels/overruns min^{-1}	Outer ring freewheels/overruns min^{-1}				Outer ring freewheels/overruns min^{-1}	Inner ring drives min^{-1}
FON 37	SF	220	2 500	2 600	SFT	220	2 500	2 600	SFZ	180	2 900	3 700	340
FON 44	SF	315	1 900	2 200	SFT	315	1 900	2 200	SFZ	250	2 250	3 000	320
FON 57	SF	630	1 400	1 750	SFT	630	1 400	1 750	SFZ	630	2 000	2 200	560
FON 72	SF	1 250	1 120	1 600	SFT	1 250	1 120	1 600	SFZ	1 250	1 550	1 850	488
FON 82	SF	1 900	1 025	1 450	SFT	1 900	1 025	1 450	SFZ	1 700	1 450	1 600	580
FON 107	SF	2 800	880	1 250	SFT	2 800	880	1 250	SFZ	2 500	1 300	1 350	520
FON 127	SF	6 300	800	1 150	SFT	6 300	800	1 150	SFZ	5 000	1 200	1 200	480
FON 140	SF	10 000	750	1 100	SFT	10 000	750	1 100	SFZ	10 000	950	1 150	380
FON 170	SF	16 000	700	1 000	SFT	16 000	700	1 000	SFZ	14 000	880	1 000	352
FON 200	SF	25 000	630	900	SFT	25 000	630	900	SFZ	20 000	680	900	272

The maximum transmissible torque is 2 times the specified nominal torque. See page 14 for determination of selection torque.
The specified maximum speeds apply for installation conditions as given with Complete Freewheels. Knowing the actual installation conditions higher speeds can be permitted under some circumstances.

Freewheel Size	Bore d		A	B	D	F	G**	J	L	P	T	Z**	Weight kg
	Standard mm	max. mm											
FON 37	20	25*	18,5	25	85	55	M 6	37	35	0,5	70	6	0,8
FON 44	25	32*	18,5	25	95	62	M 6	44	35	0,5	80	8	1,0
FON 57	30	42*	23,5	30	110	75	M 8	57	45	0,5	95	8	1,7
FON 72	40	55*	29,5	38	132	90	M 8	72	60	1,0	115	12	3,0
FON 82	55	65*	31,0	40	145	100	M 10	82	60	1,0	125	12	4,0
FON 107	70	85*	33,0	45	170	125	M 10	107	65	1,0	150	12	6,0
FON 127	90	100*	58,0	68	200	145	M 12	127	75	1,0	180	12	11,5
FON 140	100	115*	58,0	68	250	180	M 16	140	75	1,0	225	12	17,0
FON 170	120	140*	60,0	70	290	210	M 16	170	75	1,0	258	16	24,0
FON 200	140	155	73,0	85	320	240	M 16	200	85	1,5	288	16	34,0

Freewheels with bore diameters highlighted blue in the table are available with short delivery times.

Keyway according to DIN 6885, page 1 • Tolerance of keyway width JS10.

* Keyway according to DIN 6885, page 3 • Tolerance of keyway width JS10.

** Z = Number of fastening holes for screws G on pitch circle T.

for bolting to the face
with sprag lift-off X and torque limiting



Application as

▶ Backstop

for continuous conveyor installations with multiple drives in which each drive is equipped with a backstop.

Features

Integrated Freewheels FXRV and FXRT are sprag freewheels without bearing support and with sprag lift-off X. They consist of the Integrated Freewheels FXM (refer to pages 60 to 65) with additional torque limiter.

The sprag lift-off X ensures a wear-free free-wheeling operation when the inner ring rotates at high speed.

In continuous conveyor installations with multiple drives it is important to consider the problem of the unequal distribution of backdriving torque to the individual drives and backstops. As soon as the installation comes to a standstill, the entire backdriving torque is applied primarily to a single backstop, due to differences in the play and elasticity of the drives involved. In installations equipped with backstops without torque limiters, the individual gearboxes and the corresponding backstops must be designed to accommodate the entire backdriving torque of the conveyor installation in order to ensure safety.

The problem of the unequal distribution of backdriving torque is solved by using backstops FXRV and FXRT with torque limiting. The torque limiter which is built into the backstop slips temporarily when the specified torque is exceeded until the other backstops engage in succession. In this way, the entire backdriving torque of the conveyor installation is distributed to the individual gearboxes and backstops. Furthermore, dynamic peak torques which occur during the locking process are reduced, thereby protecting the gearboxes against damaging peak torques. For this reason the use of backstops FXRV and FXRT with torque limiting in continuous conveyor installations with multiple drives enables the application of gearboxes with smaller dimensions.

Advantages

- Protection of gearboxes from overload by unequal load distribution in multiple drives
- Protection of gearboxes from dynamic peak torques during the locking process
- Smaller gearboxes can be used without negatively affecting the safety
- Protection of the backstops, as dynamic peak torques are reduced by temporarily slipping

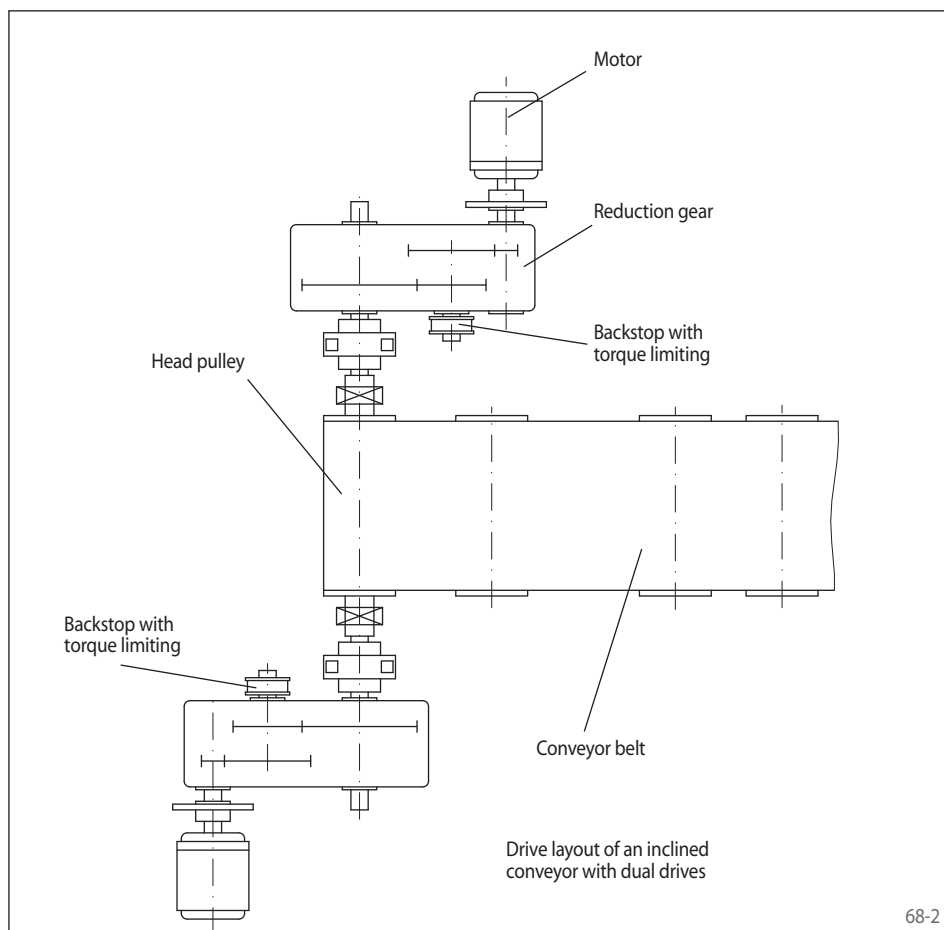

for bolting to the face with sprag lift-off X and torque limiting

Integrated Freewheels FXRV with torque limiting and without release function

This series of backstops with torque limiting is the basic version. The design and the available standard sizes are shown on page 70.

Integrated Freewheels FXRT with torque limiting and with release function

This series is designed in the same way as series FXRV; as an addition, a finely controllable release function is built in. The design, the description of the release function and the available standard sizes are shown on page 71.

The backstops with controllable release function are used if a controlled relaxing of the belt or the unit – perhaps in the case of a jam on the pulley drum – or a limited reverse movement of the conveyor system is required.

Selection torque

The following determination of the selection torque applies to multiple-drives installations in which each drive has the same motor power. Please contact us in case of different motor powers.

If the backdriving torque M_L per drive is known, then the selection torque M_A for the particular backstop should be determined as follows:

$$M_A = 1,2 \cdot M_L \text{ [Nm]}$$

If, however, only the nominal power per drive P_0 [kW] is known, then this applies:

$$M_A = 1,2 \cdot 9550 \cdot F^2 \cdot P_0 / n_{SP} \text{ [Nm]}$$

In these equations:

M_A = Selection torque of the particular backstop [Nm]

$$M_L = 9550 \cdot F \cdot P_L / n_{SP} \text{ [Nm]}$$

= Static backdriving torque of the load for each drive referring to the particular backstop shaft [Nm]

P_L = Lifting capacity per drive at full load [kW]

= Lifting height [m] multiplied by the load that is being conveyed per second divided by the number of drives [kN/s]

P_0 = Nominal power of motor [kW]

n_{SP} = Speed of backstop shaft [min⁻¹]

F = Selection factor

$$F = \frac{\text{Lifting capacity}}{\text{Lifting capacity} + \text{Power loss}}$$

After calculating M_A , the size of the particular backstop must be selected in accordance with the catalogue tables in such a way that in all cases this applies:

$$M_R \geq M_A$$

M_R = Maximum slipping torque of the particular backstop in accordance with the table values on pages 70 and 71 [Nm]

Approximate values for F:

Type of installation	F	F ²
Conveyor belts, angle up to 6°	0,71	0,50
Conveyor belts, angle up to 8°	0,78	0,61
Conveyor belts, angle up to 10°	0,83	0,69
Conveyor belts, angle up to 12°	0,86	0,74
Conveyor belts, angle up to 15°	0,89	0,79
Screw pumps	0,93	0,87
Ball mills, drying drums	0,85	0,72
Bucket conveyors, elevators	0,92	0,85
Hammer mills	0,93	0,87

In each case, the sum of the slipping torques of the particular backstops must be 1,2 times higher than the static backdriving torque of the installation (also at overload). The torques specified in the tables are maximum values. Lower values can be set upon request. If in doubt, please contact us stating the precise description of the installation and the operating conditions. It is preferable to use the questionnaire on page 110.

Example

Dual-drive system

Motor power per drive: $P_0 = 630$ kW

Type of installation:

Conveyor belt with 8° incline => $F^2 = 0,61$

Speed per backstop shaft:

$$n_{SP} = 360 \text{ min}^{-1}$$

Selection torque of the particular backstop:

$$M_A = 1,2 \cdot 9550 \cdot 0,61 \cdot 630 / 360 \text{ [Nm]}$$

$$= 12234 \text{ Nm}$$

The following rule applies in all cases:

$$M_R \geq M_A$$

=> FXRT or FXRV 200 - 63 MX are the suitable, economical backstop sizes.

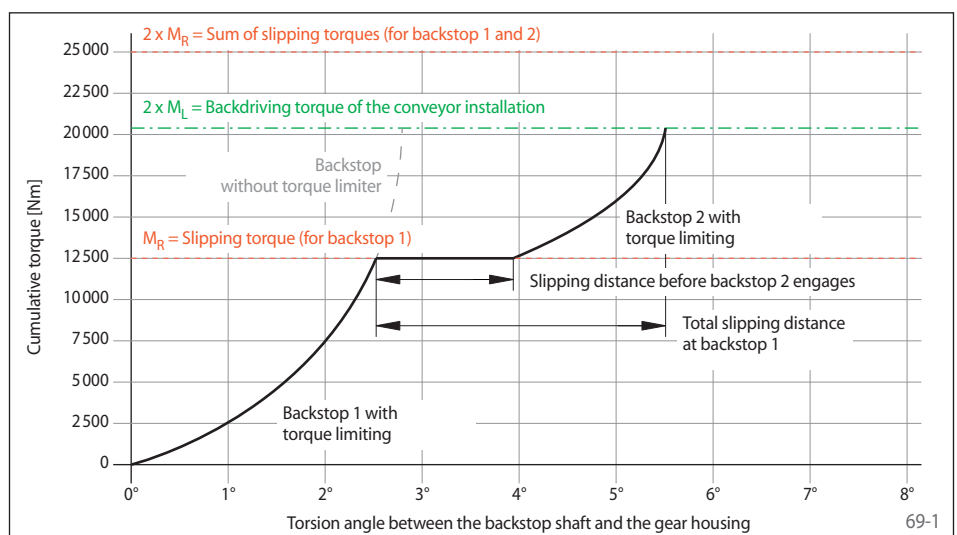

Integrated Freewheels FXRV

for bolting to the face
with sprag lift-off X and torque limiting

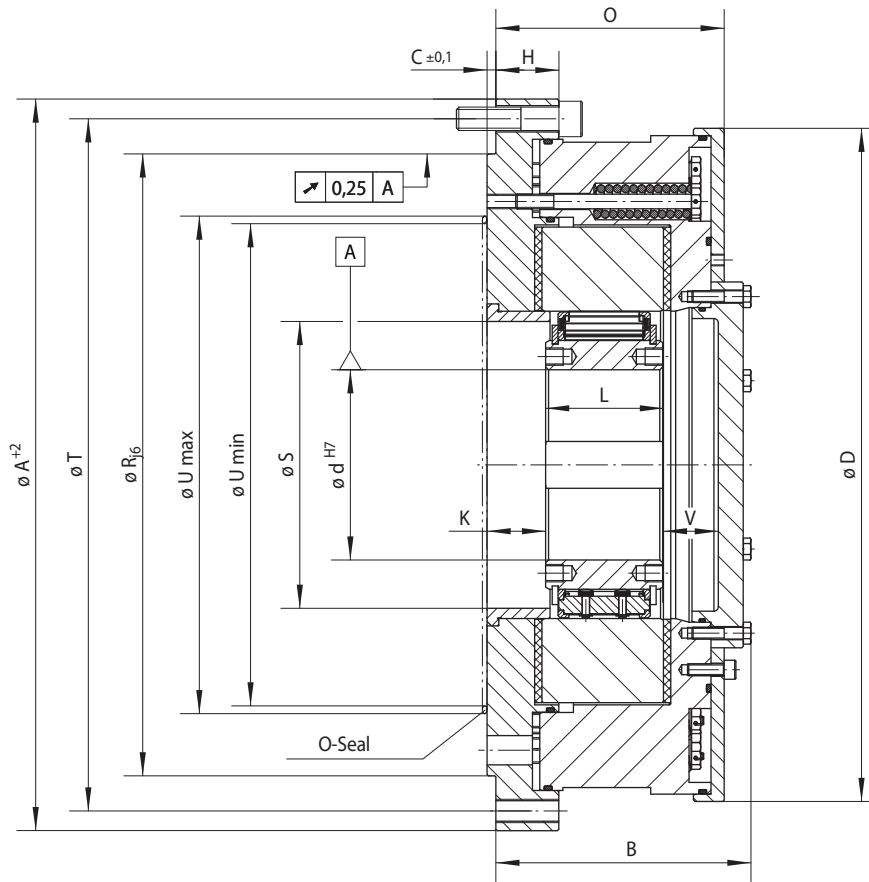

70-1

Backstop	Type with sprag lift-off X For extended service life using sprag lift-off at high speed rotating inner ring		Dimensions																		

Freewheel Size	Type	Slipping torque M_R Nm	Sprag lift-off at inner ring speed min^{-1}	Max. speed Inner ring freewheels min^{-1}	Bore d		A mm	B mm	C mm	D mm	G** mm	H mm	K mm	L mm	O mm	R mm	S mm	T mm	U***		V mm	Z**	Weight kg
					Standard mm	max. mm													min. mm	max. mm			
FXRV 85 - 40	MX	1 400	430	6000	60	65	330	143	6	295	M 12	37	29	60	127	280	110	308	165	215	43	6	57
FXRV 100 - 50	MX	2 300	400	4500	70	80*	350	150	6	311	M 12	39	31	70	134	300	125	328	180	240	38	6	65
FXRV 120 - 50	MX	3 400	320	4000	80	95	400	150	6	360	M 16	36	31	70	134	340	145	373	200	260	38	6	86
FXRV 140 - 50	MX	4 500	320	3000	90	110	430	160	6	386	M 16	36	31	70	134	375	165	403	220	280	50	6	102
FXRV 170 - 63	MX	9 000	250	2700	100	130	500	175	6	460	M 16	43	40	80	156	425	196	473	250	340	38	6	163
FXRV 200 - 63	MX	12 500	240	2100	110	155	555	175	6	516	M 16	49	40	80	156	495	226	528	275	390	38	6	205
FXRV 240 - 63	LX	21 200	220	3000		185	710	195	8	630	M 20	50	50	90	170	630	290	670	355	455	45	12	347
FXRV 260 - 63	LX	30 000	210	2500		205	750	205	8	670	M 20	50	50	105	183	670	310	710	375	500	40	12	411
FXRV 290 - 70	LX	42 500	200	2500		230	850	218	8	755	M 24	52	50	105	190	730	335	800	405	560	48	12	562
FXRV 310 - 96	LX	53 000	195	2100		240	900	260	10	800	M 24	63	63	120	240	775	355	850	435	600	69	12	792
FXRV 360 - 100	LX	75 000	180	1800		280	975	267	10	870	M 30	63	63	125	243	850	400	925	485	670	71	12	942
FXRV 410 - 100	LX	100 000	170	1500		300	1060	267	10	950	M 30	63	63	125	243	950	450	1000	535	750	71	12	1053

Keyway according to DIN 6885, page 1 • Tolerance of keyway width JS10. * Keyway according to DIN 6885, page 3 • Tolerance of keyway width JS10.

** Z = Number of fastening holes for screws G (DIN EN ISO 4762) on pitch circle T.*** Area for O-ring sealing.

See page 69 for determination of selection torque. Other freewheel sizes upon request.

Torques

The Integrated Freewheels FXRV are supplied with a set slipping torque M_R of the torque limiter. The static backdriving torque M_L of the installation (also in the case of an overload) must under no circumstances achieve the sum of the slipping torques M_R of the provided Integrated Freewheels. The slipping torques M_R specified in the table are maximum values; lower values can be set.

Mounting

The Integrated Freewheels FXRV are without bearing support, therefore it must be ensured that the run out (T.I.R.) between the pilot diameter R and the shaft diameter d does not exceed the value 0,25 mm.

Dimension C applies for the Integrated Freewheel. The centering depth of the customer attachment part must be at least $C + 0,2$ mm. The tolerance of the pilot diameter R of the attachment part must be ISO H7.

The tolerance of the shaft must be ISO h6 or j6.

Example for ordering

Freewheel size FXRV 170-63 MX, type with sprag lift-off X, 100 mm bore and slipping torque 9 000 Nm:

- FXRV 170 - 63 MX, d = 100 mm, $M_R = 9\,000$ Nm

for bolting to the face
with sprag lift-off X, torque limiting and release function

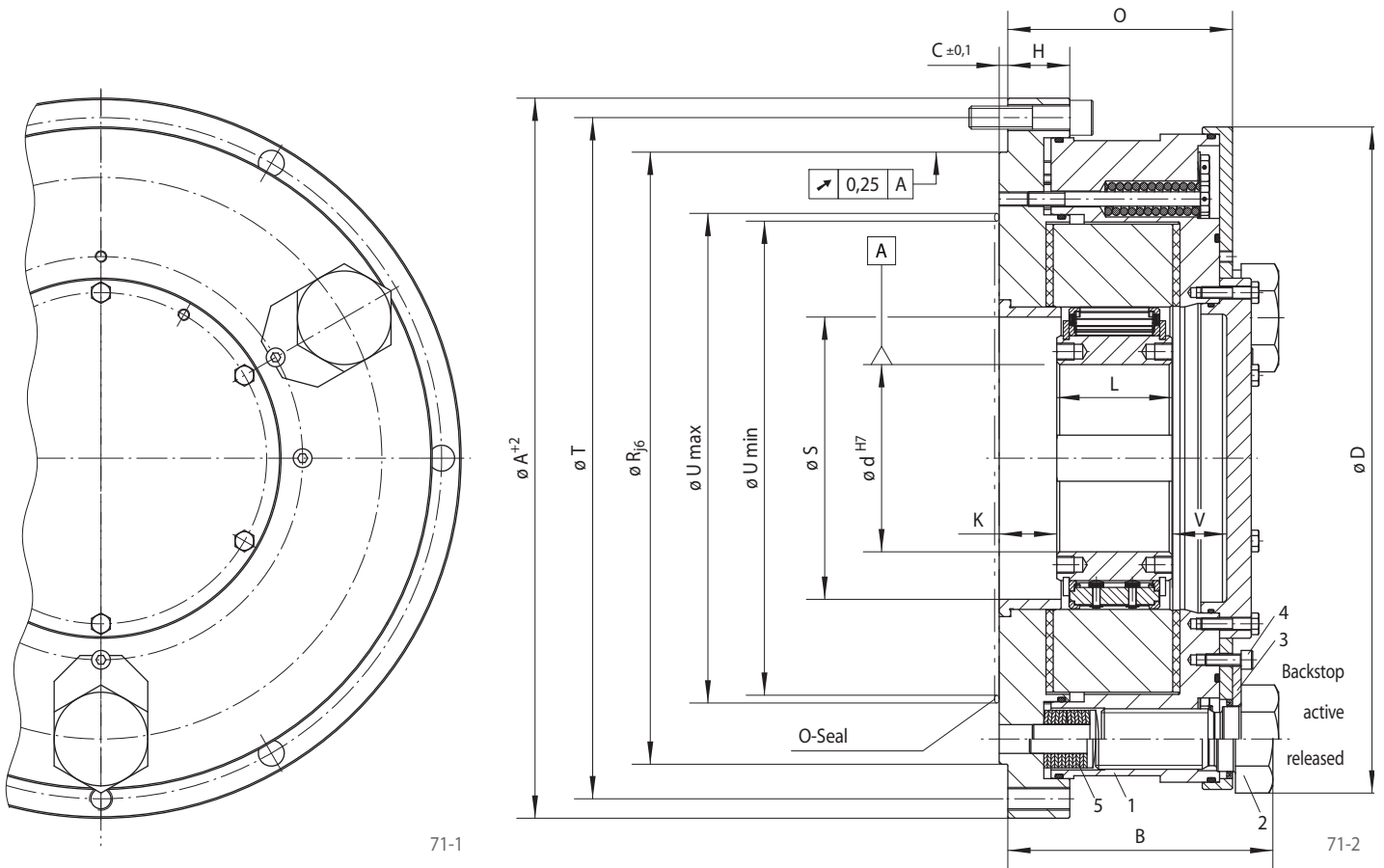

Backstop	Type with Sprag lift-off X For extended service life using sprag lift-off at high speed rotating inner ring		Dimensions																			

Freewheel Size	Type	Slipping torque M_R Nm	Sprag lift-off at inner ring speed min^{-1}	Max. speed Inner ring freewheels min^{-1}	Bore d		A mm	B mm	C mm	D mm	G** mm	H mm	K mm	L mm	O mm	R mm	S mm	T mm	U*** mm		V mm	Z** mm	Weight kg
					Standard mm	max. mm													min. mm	max. mm			
FXRT 85 - 40	MX	1 400	430	6000	60	65	330	148	6	295	M 12	37	29	60	127	280	110	308	165	215	43	6	60
FXRT 100 - 50	MX	2 300	400	4500	70	80*	350	159	6	311	M 12	39	31	70	134	300	125	328	180	240	38	6	66
FXRT 120 - 50	MX	3 400	320	4000	80	95	400	159	6	360	M 16	36	31	70	134	340	145	373	200	260	38	6	87
FXRT 140 - 50	MX	4 500	320	3000	90	110	430	163	6	386	M 16	36	31	70	134	375	165	403	220	280	50	6	104
FXRT 170 - 63	MX	9 000	250	2700	100	130	500	188	6	460	M 16	43	40	80	156	425	196	473	250	340	38	6	166
FXRT 200 - 63	MX	12 500	240	2100	110	155	555	188	6	516	M 16	49	40	80	156	495	226	528	275	390	38	6	209
FXRT 240 - 63	LX	21 200	220	3000		185	710	210	8	630	M 20	50	50	90	170	630	290	670	355	455	45	12	355
FXRT 260 - 63	LX	30 000	210	2500		205	750	223	8	670	M 20	50	50	105	183	670	310	710	375	500	40	12	418
FXRT 290 - 70	LX	42 500	200	2500		230	850	243	8	755	M 24	52	50	105	190	730	335	800	405	560	48	12	574
FXRT 310 - 96	LX	53 000	195	2100		240	900	293	10	800	M 24	63	63	120	240	775	355	850	435	600	69	12	805

Keyway according to DIN 6885, page 1 • Tolerance of keyway width JS10. * Keyway according to DIN 6885, page 3 • Tolerance of keyway width JS10.

** Z = Number of fastening holes for screws G (DIN EN ISO 4762) on pitch circle T. *** Area for O-ring sealing.

See page 69 for determination of selection torque. Other freewheel sizes upon request.

Torques

The Integrated Freewheels FXRT are supplied with a set slipping torque M_R of the torque limiter. The static backdriving torque M_L of the installation (also in the case of an overload) must under no circumstances achieve the sum of the slipping torques M_R of the provided Integrated Freewheels. The slipping torques M_R specified in the table are maximum values; lower values can be set.

Mounting

The Integrated Freewheels FXRT are without bearing support, therefore it must be ensured that the run out (T.I.R.) between the pilot diameter R and the shaft diameter d does not exceed the value 0,25 mm.

Dimension C applies for the Integrated Freewheel. The centering depth of the customer attachment part must be at least C + 0,2 mm. The tolerance of the pilot diameter R of the attachment part must be ISO H7.

The tolerance of the shaft must be ISO h6 or j6.

Release function

The finely controllable release function consists basically of three special screws (2) that are located in the spring pocket (1) and the safety tabs (3). To release the backstop, first of all the special screws have to be unscrewed slightly. Then the cylinder screws (4) and the safety tabs have to be removed. The special screws can then be tightened, whereupon, with the aid of the bellville spring set (5) the release procedure is finely initiated.

Internal Freewheels FXN

for press fit on the outer ring
with sprag lift-off X

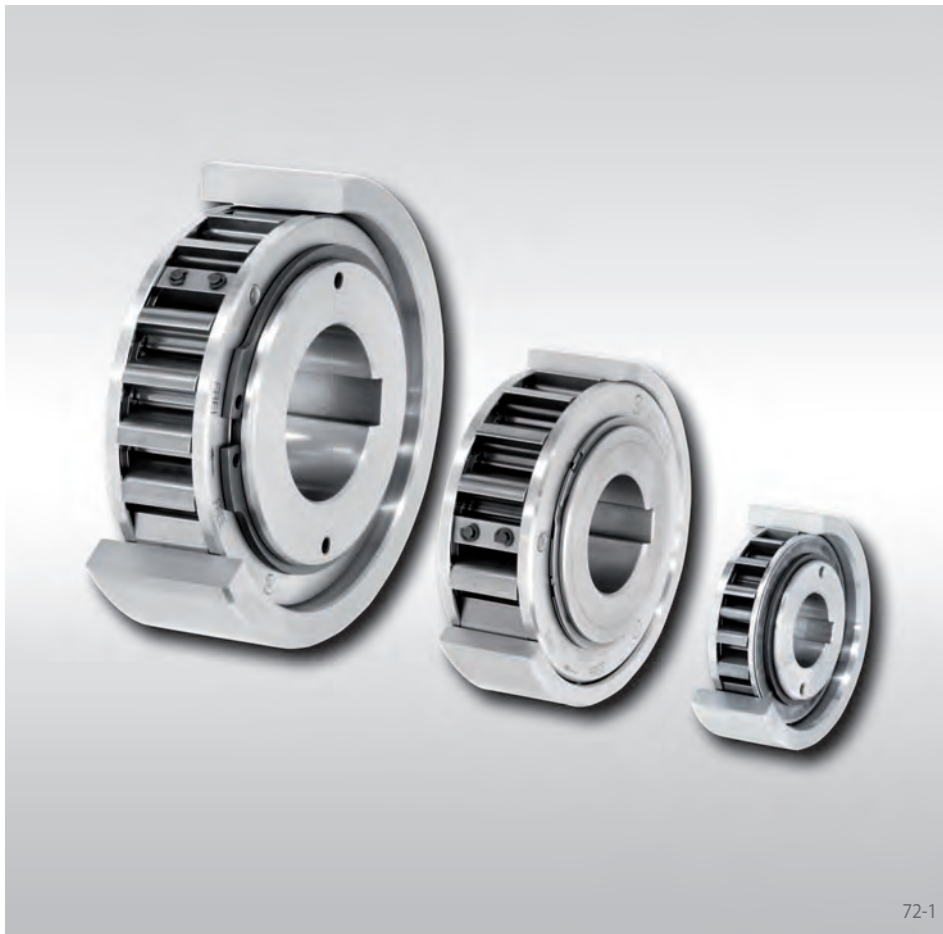

Application as

- ▶ Backstop
- ▶ Overrunning Clutch

For application as backstop in installations with high speeds in freewheeling operation.

For application as overrunning clutch in installations with low speeds in driving operation.

Features

Internal Freewheels FXN are sprag freewheels without bearing support and with sprag lift-off X.

The sprag lift-off X ensures a wear-free freewheeling operation when the inner ring rotates at high speed.

The outer ring is pressed into the customer housing. This makes compact, space-saving fitting solutions possible.

Nominal torques up to 20 500 Nm. The torque is transmitted on the outer ring by press fit.

Bores up to 130 mm. A multitude of standardized bore diameters are available with short delivery times.

Srag lift-off X

Internal Freewheels FXN are equipped with sprag lift-off X. The sprag lift-off X is used for backstops and overrunning clutches, provided that in freewheeling operation the inner ring is rotating at high speed and providing with overrunning clutches that the driving operation is conducted at low speed. In freewheeling operation, the centrifugal force F_C causes the sprag to lift off from the outer track. In this operating state, the freewheel works wear-free, i.e. with unlimited service life.

Figure 72-2 shows a freewheel with sprag lift-off X in freewheeling operation. The sprags, which are supported in a cage connected with the inner ring, rotate with the inner ring. The centrifugal force F_C that is applied in the center of gravity S of the sprag turns the sprag counterclockwise and rests against the support ring of the cage. This results in the gap a between the sprag and the outer track; the freewheel works without contact. If the inner ring speed decreases to such an extent that the effect of

the centrifugal force on the sprag is less than that of the spring force F_F , the sprag again rests on the outer ring and the freewheel is ready to lock (figure 72-3). If used as an overrunning clutch, the driving speed must not exceed 40% of the lift-off speed.

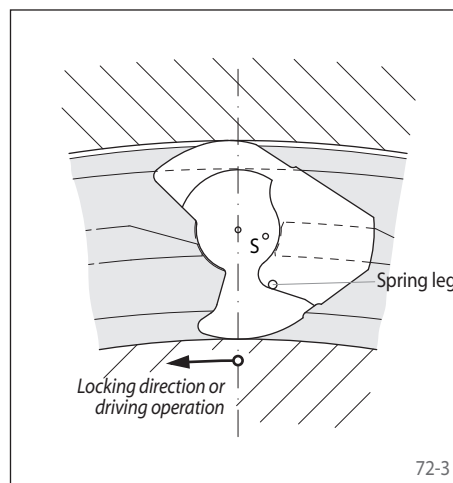
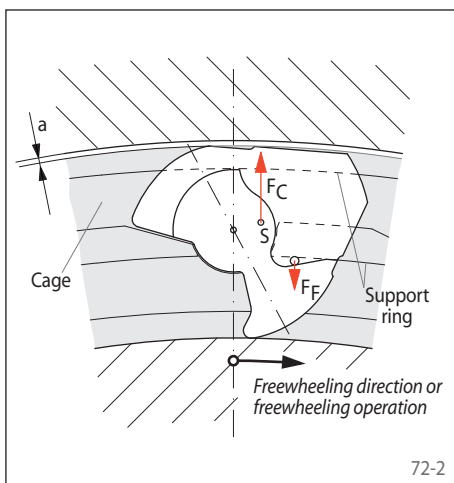

Internal Freewheels FXN

for press fit on the outer ring
with sprag lift-off X

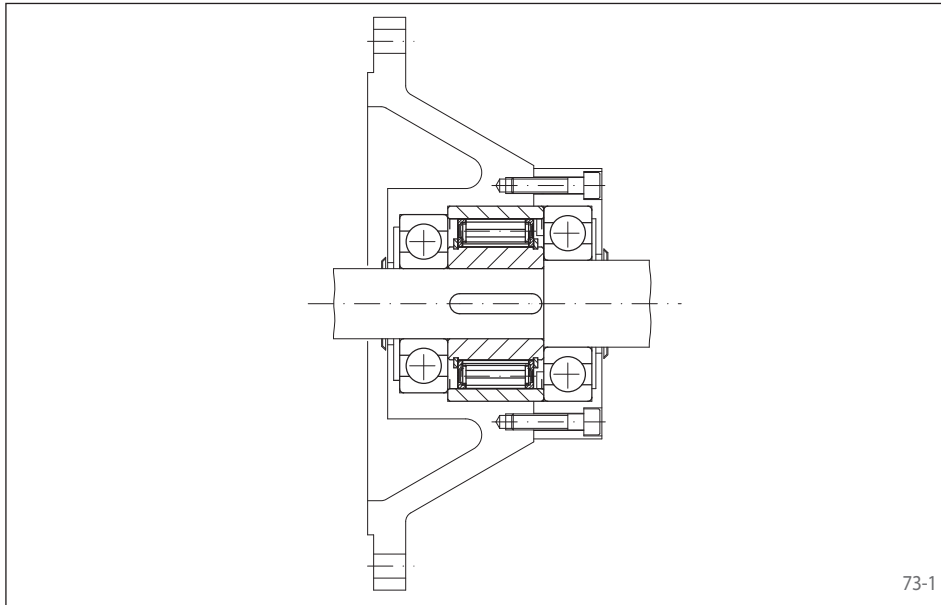

Application example

Internal Freewheel FXN 38 - 17/70 NX as a backstop, arranged in a housing adapter to attach to an electric motor. The thin outer ring that is pressed into the housing enables a space-efficient fitting solution. Due to the high shaft speeds in normal operation (freewheeling operation), the sprag lift-off X ensures a contactless and hence wear-free continuous operation.

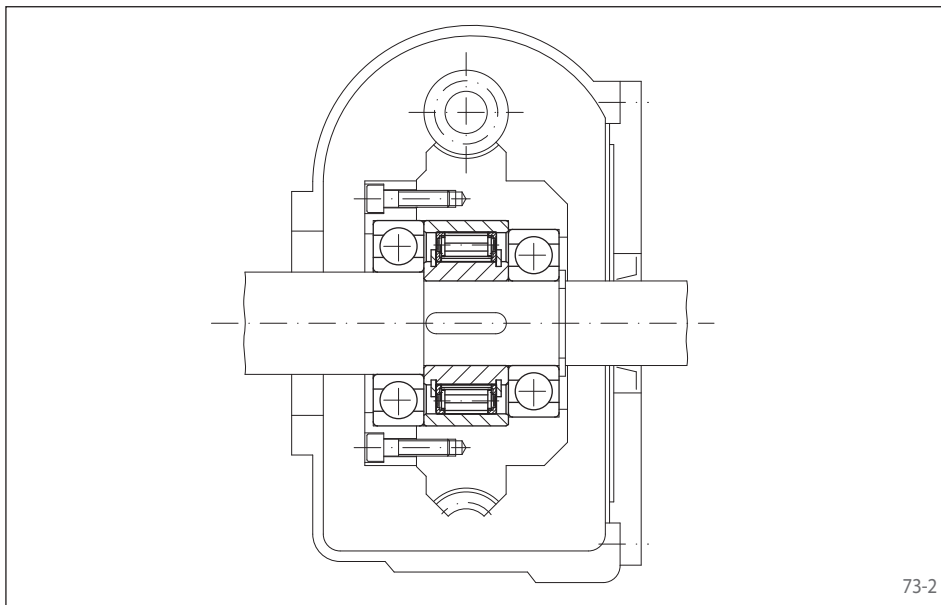

Application example

Internal Freewheel FXN 66-25/100 NX as an overrunning clutch in the creep drive of a textile machine. The freewheel installation is compactly solved by means of the thin outer ring that is pressed into the worm wheel. During set-up, the machine is driven by the worm gear and the freewheel that is working in driving operation. In normal operation (freewheeling operation), the inner ring that is located on the high speed main drive shaft overruns and automatically disengages the creep drive. With the high overrunning speed of the inner ring, the type with sprag lift-off X is used; the sprags work in freewheeling operation without contact and hence are wear-free.

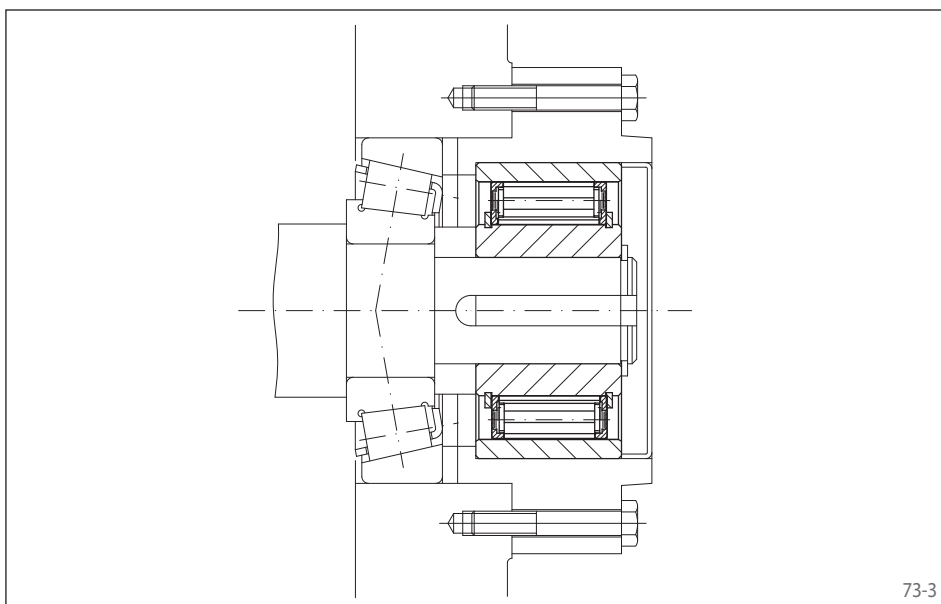

Application example

Internal Freewheel FXN 85-40/140 MX as a backstop fitted to the end of the first intermediate shaft of a spur gearbox in the drive of an inclined conveyor belt. In the case of a motor stop the conveyor belt must be held securely so that the conveyor goods do not pull the belt backwards and possibly cause serious damage. Due to the high shaft speeds in normal operation (freewheeling operation), the sprag lift-off X ensures a contactless and hence wear-free continuous operation.

for press fit on the outer ring
with sprag lift-off X

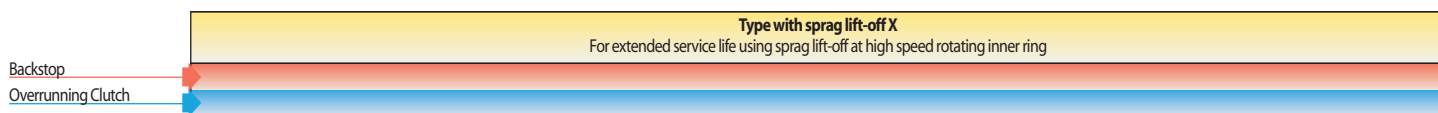
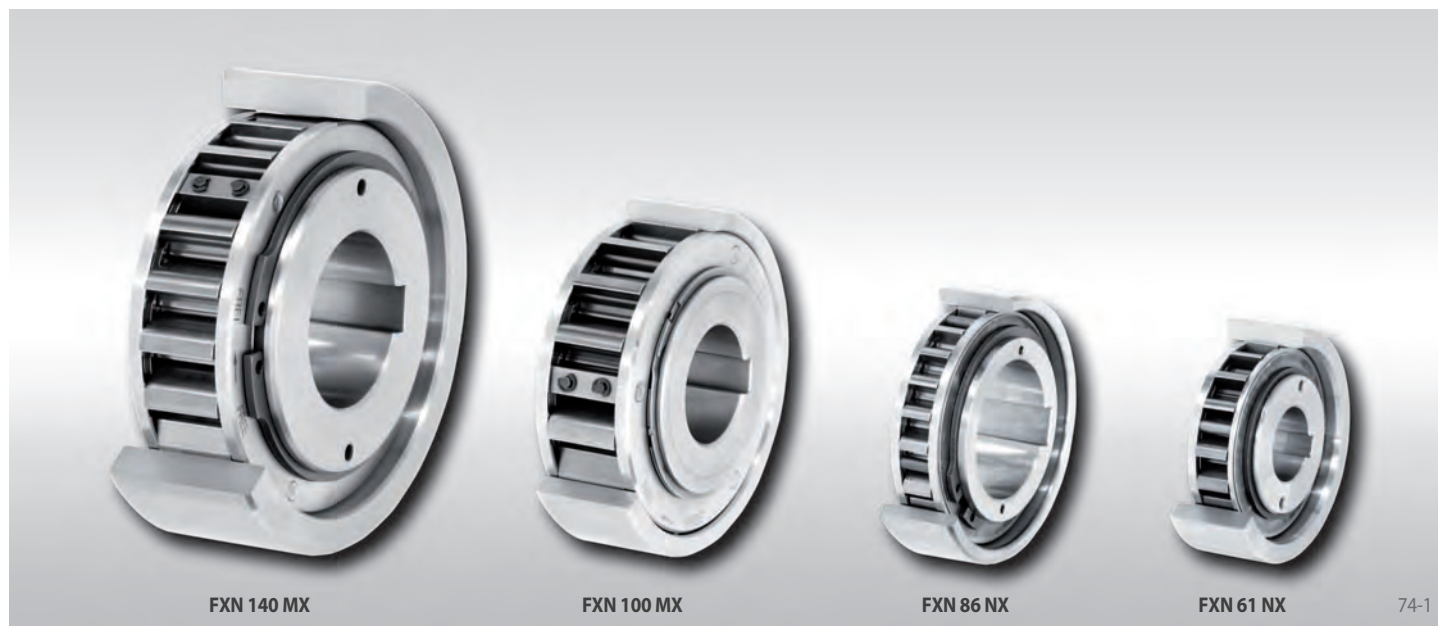

Freewheel Size	Type	Nominal torque at existing run out T.I.R.						Sprag lift-off at inner ring speed min ⁻¹	Max. speed	
		Theoretical Nominal torque ↗ 0 A Nm	↗ 0,1 A Nm	↗ 0,2 A Nm	↗ 0,3 A Nm	↗ 0,4 A Nm	↗ 0,5 A Nm		Inner ring freewheels/ overruns min ⁻¹	Outer ring drives min ⁻¹
FXN 31 - 17/60	NX	110	110	105	100			890	5 000	356
FXN 31 - 17/62	NX	110	110	105	100			890	5 000	356
FXN 38 - 17/70	NX	180	170	160	150			860	5 000	224
FXN 46 - 25/80	NX	460	450	440	430			820	5 000	328
FXN 51 - 25/85	NX	560	550	540	530			750	5 000	300
FXN 56 - 25/90	NX	660	650	640	630			730	5 000	292
FXN 61 - 19/95	NX	520	500	480	460			750	5 000	300
FXN 61 - 19/106	NX	520	500	480	460			750	5 000	300
FXN 66 - 25/100	NX	950	930	910	890			700	5 000	280
FXN 66 - 25/110	NX	950	930	910	890			700	5 000	280
FXN 76 - 25/115	NX	1 200	1 170	1 140	1 110			670	5 000	268
FXN 76 - 25/120	NX	1 200	1 170	1 140	1 110			670	5 000	268
FXN 86 - 25/125	NX	1 600	1 550	1 500	1 450			630	5 000	252
FXN 86 - 25/130	NX	1 600	1 550	1 500	1 450			630	5 000	252
FXN 101 - 25/140	NX	2 100	2 050	2 000	1 950			610	5 000	244
FXN 101 - 25/150	NX	2 100	2 050	2 000	1 950			610	5 000	244
FXN 85 - 40/140	MX	2 500	2 500	2 450	2 450	2 450	2 450	430	6 000	172
FXN 85 - 40/150	MX	2 500	2 500	2 450	2 450	2 450	2 450	430	6 000	172
FXN 100 - 40/160	MX	3 700	3 600	3 600	3 500	3 500	3 500	400	4 500	160
FXN 105 - 50/165	MX	5 200	5 200	5 100	5 000	5 000	5 000	380	4 500	152
FXN 120 - 50/198	MX	7 700	7 600	7 500	7 300	7 300	7 300	320	4 000	128
FXN 140 - 50/215	MX	10 100	10 000	9 800	9 600	9 500	9 500	320	3 000	128
FXN 170 - 63/258	MX	20 500	20 500	20 000	19 500	19 000	19 000	250	2 700	100

The maximum transmissible torque is 2 times the specified nominal torque. See page 14 for determination of selection torque.
The theoretical nominal torque applies only for ideal concentricity between the inner and outer ring. In practice, the concentricity is affected by the bearing play and centering errors of the neighbouring parts. Then the nominal torques specified in the table apply, whilst taking into consideration the existing run out (T.I.R.).
Higher speeds upon request.

Mounting

Internal Freewheels FXN are without bearing support. Concentric alignment of inner and outer ring must be provided by the customer. The permissible run out (T.I.R.) must be observed.

The torque is transmitted on the outer ring by press fit. In order to transmit the torques speci-

fied in the table, the outer ring must be accommodated in a housing with an external diameter K. The housing is made of steel or grey cast iron in minimum quality GG-20. When using other housing materials or smaller external diameters, we urge you to contact us regarding the transmissible torque.

The tolerance of the housing bore is specified in the table under dimension D.

The tolerance of the shaft must be ISO h6 or j6.

for press fit on the outer ring
with sprag lift-off X

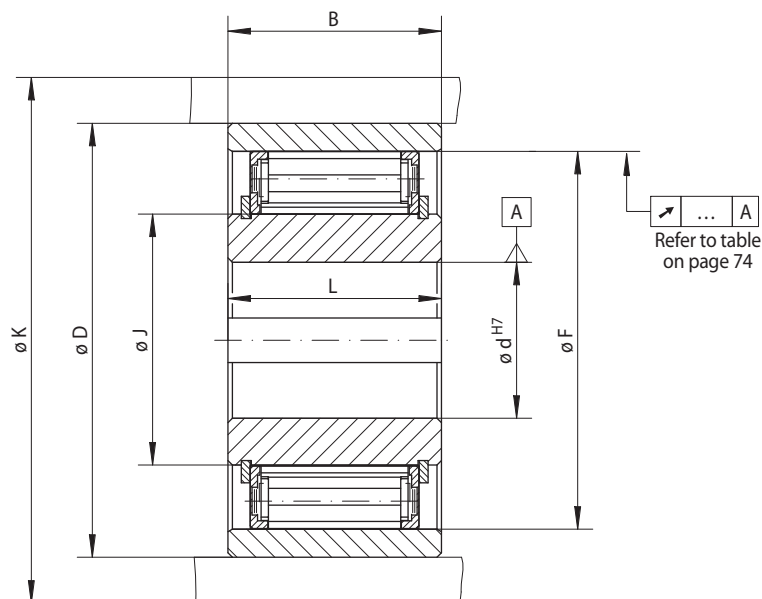

75-1

Freewheel size	Type	Bore d			B mm	D mm	F mm	J mm	K min. mm	L mm	Weight kg
		Standard mm	mm	max. mm							
FXN 31 - 17/60	NX	20*		20*	25	60 P6	55	31	85	24	0,3
FXN 31 - 17/62	NX	20*		20*	25	62 P6	55	31	85	24	0,4
FXN 38 - 17/70	NX	25*		25*	25	70 P6	62	38	90	24	0,4
FXN 46 - 25/80	NX	30		30	35	80 P6	70	46	95	35	0,8
FXN 51 - 25/85	NX	35		36	35	85 P6	75	51	105	35	0,8
FXN 56 - 25/90	NX	35	40	40	35	90 P6	80	56	110	35	0,9
FXN 61 - 19/95	NX	35	40	45*	26	95 P6	85	61	120	25	0,8
FXN 61 - 19/106	NX	35	40	45*	25	106 H7	85	61	120	25	1,2
FXN 66 - 25/100	NX	40	45	48	30	100 P6	90	66	132	35	1,1
FXN 66 - 25/110	NX	40	45	48	40	110 P6	90	66	132	35	1,8
FXN 76 - 25/115	NX	50	55	60*	40	115 P6	100	76	140	35	1,7
FXN 76 - 25/120	NX	50	55	60*	32	120 J6	100	76	140	35	1,8
FXN 86 - 25/125	NX	50	60	70	40	125 P6	110	86	150	40	2,3
FXN 86 - 25/130	NX	50	60	70	40	130 P6	110	86	150	40	2,6
FXN 101 - 25/140	NX	75		80*	45	140 P6	125	101	175	50	3,1
FXN 101 - 25/150	NX	75		80*	45	150 P6	125	101	175	50	3,6
FXN 85 - 40/140	MX	60		65	45	140 P6	125	85	175	60	3,2
FXN 85 - 40/150	MX	60		65	45	150 P6	125	85	175	60	4,2
FXN 100 - 40/160	MX	70		80*	50	160 P6	140	100	190	60	5,1
FXN 105 - 50/165	MX	80		85	62	165 P6	145	105	195	62	5,8
FXN 120 - 50/198	MX	80		95	70	198 H6	160	120	210	70	8,6
FXN 140 - 50/215	MX	90		110	69	215 J6	180	140	245	70	14,0
FXN 170 - 63/258	MX	100		130	80	258 H6	210	170	290	80	21,0

■ Freewheels with bore diameters highlighted blue in the table are available with short delivery times.

Keyway according to DIN 6885, page 1 • Tolerance of keyway width JS10.

* Keyway according to DIN 6885, page 3 • Tolerance of keyway width JS10.

Lubrication

At speeds in excess of the sprag lift-off speed, no special lubrication is required; the freewheel functions maintenance-free.

When operating below the sprag lift-off speed, an oil lubrication of the specified quality must be provided.

Example for ordering

Freewheel size FXN 61 - 19/95, type with sprag lift-off X and 35 mm bore:

- FXN 61-19/95 NX, d = 35 mm

Internal Freewheels FCN ... R

for press fit on the outer ring
with rollers

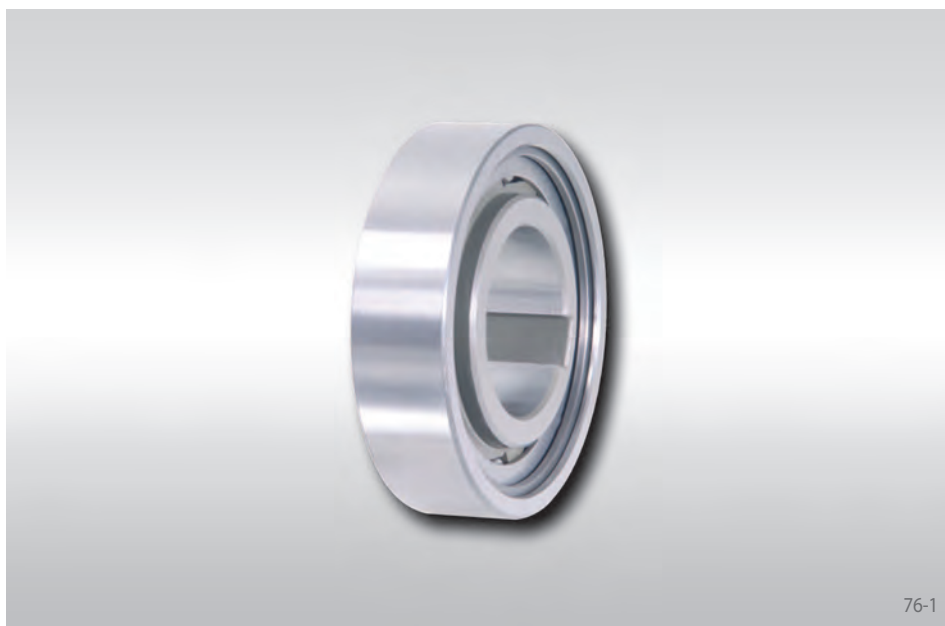

Application as

- ▶ Backstop
- ▶ Overrunning Clutch
- ▶ Indexing Freewheel

Features

Internal Freewheels FCN ... R are roller free-wheels without bearing support and with series 62 ball bearing dimensions.

The outer ring is pressed into the customer housing. This makes compact, space-saving fitting solutions possible.

Nominal torques up to 840 Nm. The torque is transmitted on the outer ring by press fit.

Bores up to 80 mm.

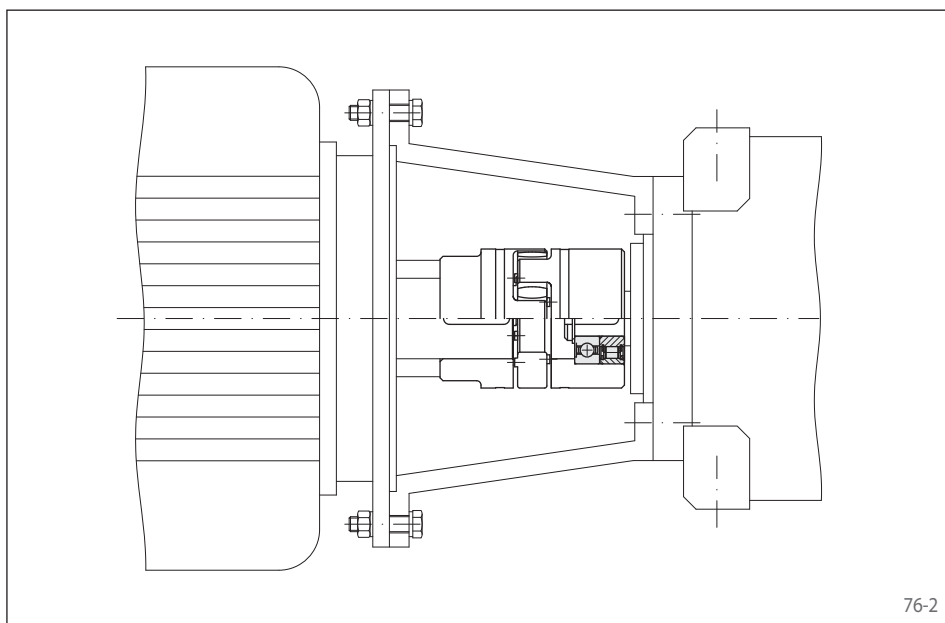

Application example

Internal Freewheel FCN 30 R as overrunning freewheel in the drive of the roof brush of an automatic car washing facility. The freewheel is arranged in the hub of a shaft coupling that connects the motor and the reduction gear. The freewheel prevent the drive from pushing the roof brush uncontrolled down onto the car roof in the event of a fault. The roof brush is raised by the freewheels that are working in driving operation. The direction of motor rotation changes in order to lower the brush. The downwards movement of the roof brush is performed by its own weight at the speed specified by the motor. In the case of an uncontrolled lowering of the roof brush on the car roof, the drive is automatically disengaged via the freewheel. The brush rests on the roof under its own weight, while the freewheel which is working in driving operation enables the drive to continue to turn in the lowering direction without causing any damage.

for press fit on the outer ring
with rollers

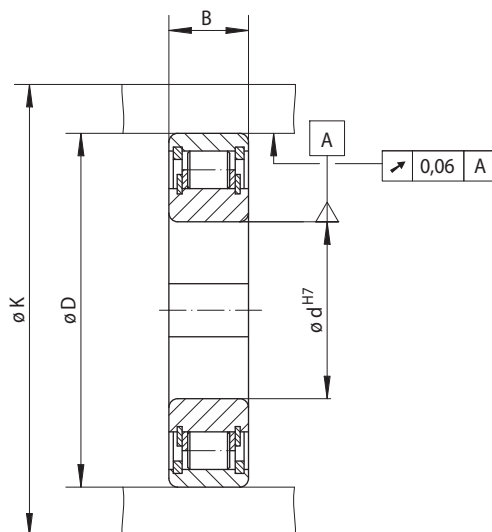

77-1

Indexing Freewheel Overrunning Clutch Backstop	Standard type For universal use	Dimensions

Freewheel Size	Type	Nominal torque M_N Nm	Max. speed		Bore d mm	B mm	D mm	K mm	Weight kg
			Inner ring freewheels/ overruns min^{-1}	Outer ring freewheels/ overruns min^{-1}					
FCN 8	R	3,2	4 300	6 700	8	8	24	28	0,02
FCN 10	R	7,3	3 500	5 300	10	9	30	35	0,03
FCN 12	R	11,0	3 200	5 000	12	10	32	37	0,05
FCN 15	R	12,0	2 800	4 400	15*	11	35	40	0,08
FCN 20	R	40,0	2 200	3 300	20*	14	47	54	0,12
FCN 25	R	50,0	1 900	2 900	25*	15	52	60	0,15
FCN 30	R	90,0	1 600	2 400	30*	16	62	70	0,24
FCN 35	R	135,0	1 350	2 100	35*	17	72	80	0,32
FCN 40	R	170,0	1 200	1 900	40*	18	80	90	0,40
FCN 45	R	200,0	1 150	1 750	45*	19	85	96	0,45
FCN 50	R	220,0	1 050	1 650	50*	20	90	100	0,50
FCN 60	R	420,0	850	1 350	60*	22	110	122	0,80
FCN 80	R	840,0	690	1 070	80*	26	140	155	1,40

■ Freewheels with bore diameters highlighted blue in the table are available with short delivery times.

The maximum transmissible torque is 2 times the specified nominal torque. See page 14 for determination of selection torque.

Keyway according to DIN 6885, page 1 • Tolerance of keyway width JS10.

* Keyway according to DIN 6885, page 3 • Tolerance of keyway width JS10.

Mounting

Internal freewheels FCN ... R are without bearing support. Concentric alignment of inner and outer ring must be provided by the customer.

The torque is transmitted on the outer ring by press fit. In order to transmit the torques specified in the table, the outer ring must be accommodated in a housing with an external diameter K. The housing is made of steel or grey cast iron in minimum quality GG-20. When using other housing materials or smaller external diameters, we urge you to contact us regarding the transmissible torque.

The tolerance of the housing bore D must be ISO H7 or J6 and the tolerance of the shaft must be ISO h6 or j6.

Lubrication

An oil lubrication of the specified quality must be provided.

Example for ordering

Freewheel size FCN 30, standard type:

- FCN 30 R

Internal Freewheels FDN

for press fit on the outer ring
with sprags

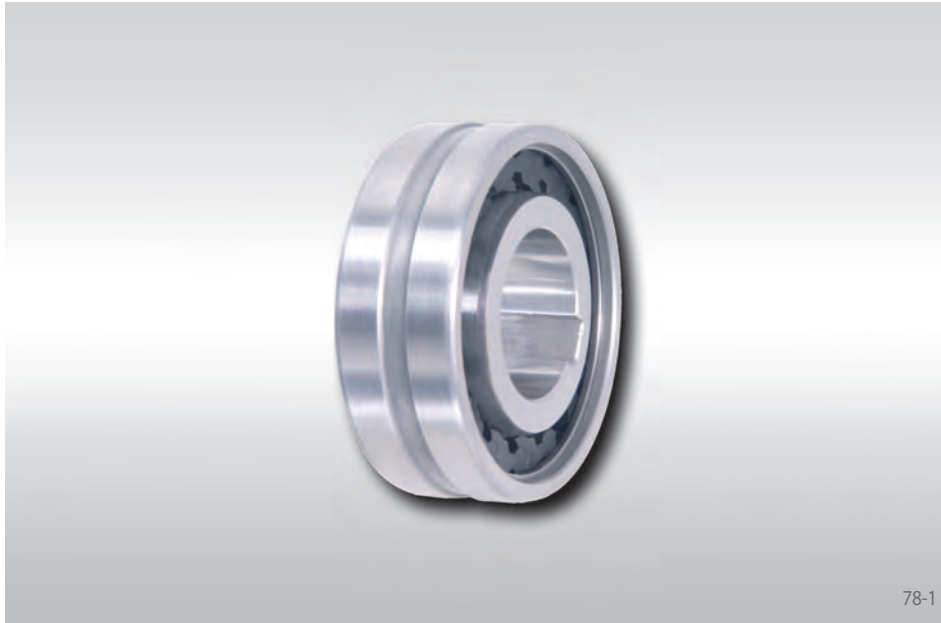

78-1

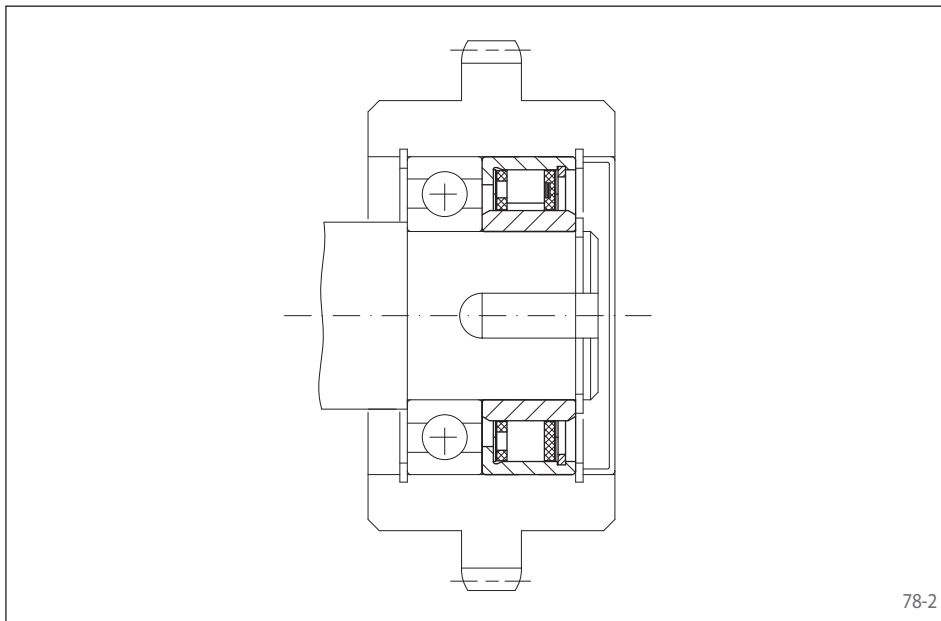

78-2

Application as

- ▶ Backstop
- ▶ Overrunning Clutch
- ▶ Indexing Freewheel

Features

Internal Freewheels FDN are sprag freewheels with anti-friction bearing dimensions.

The standard type does not have bearing support. In the case of the standard type, every second sprag has been replaced by a cylindrical roller; this freewheel can accept radial forces.

Nominal torques up to 2 400 Nm. The torque is transmitted on the outer ring by press fit.

Bores up to 80 mm. A multitude of standardized bore diameters are available with short delivery times.

Application example

Internal Freewheel FDN 40 CFR in standard type with bearing support as an overrunning clutch on the shaft end of the main drive of a textile machine. The gear wheel is linked to an auxiliary drive. In normal operation (freewheeling operation) the inner ring overruns and the gear wheel with the pressed-in outer ring is at a standstill. During set-up, the machine is driven by the slowly running auxiliary drive via the gear wheel and the freewheel that is working in driving operation.

for press fit on the outer ring
with sprags

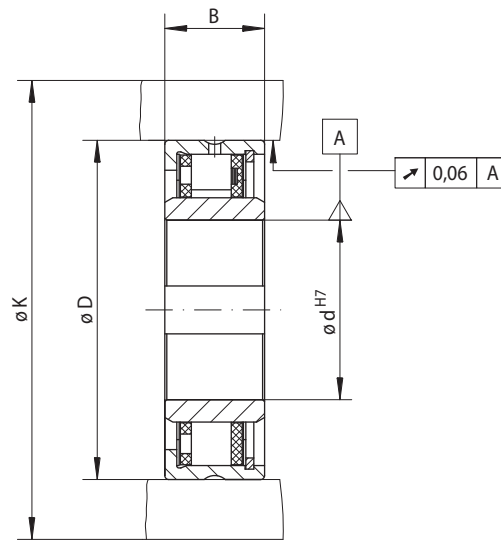

79-1

	Standard type For universal use	Standard type with bearing support For universal use	Dimensions
Indexing Freewheel			
Overrunning Clutch			
Backstop			

Freewheel Size	Type	Nominal torque M_N Nm	Max. speed		Type	Nominal torque M_N Nm	Max. speed		Load rating of bearing support		Bore d		B mm	D mm	K mm	Weight kg
			Inner ring freewheels/overruns min^{-1}	Outer ring freewheels/overruns min^{-1}			Inner ring freewheels/overruns min^{-1}	Outer ring freewheels/overruns min^{-1}	dynamic C N	static C_0 N	Standard mm	max. mm				
FDN 15	CFH	16	3 875	3 925	CFR	8	3 875	3 925	7 800	4 200	8	8	20	37	50	0,1
FDN 20	CFH	28	3 375	3 450	CFR	14	3 375	3 450	8 300	4 200	12	12	20	42	55	0,1
FDN 25	CFH	48	2 900	3 050	CFR	24	2 900	3 050	10 700	5 600	15	15	20	47	60	0,1
FDN 30	CFH	75	2 525	2 675	CFR	36	2 525	2 675	12 900	7 000	20*	20*	20	52	65	0,2
FDN 40	CFH	160	1 900	2 150	CFR	71	1 900	2 150	15 000	8 400	25	28*	22	62	80	0,2
FDN 50	CFH	260	1 475	1 775	CFR	120	1 475	1 775	18 400	11 300	35	35	22	72	95	0,4
FDN 65	CFH	430	1 200	1 550	CFR	200	1 200	1 550	21 400	14 100	50	50*	25	90	120	0,7
FDN 80	CFH	650	950	1 350	CFR	300	950	1 350	23 800	17 800	60	60	25	110	140	1,2
FDN 105	CFH	2 400	800	1 175	CFR	1 100	800	1 175	48 600	45 000	75	80	35	130	165	3,2

■ Freewheels with bore diameters highlighted blue in the table are available with short delivery times.

The maximum transmissible torque is 2 times the specified nominal torque. See page 14 for determination of selection torque.

The maximum speed values listed above apply to installation conditions as they are given for Complete Freewheels. If the actual installation conditions are known, higher speeds may be permitted under certain circumstances.

Keyway according to DIN 6885, page 1 • Tolerance of keyway width JS10.

* Keyway according to DIN 6885, page 3 • Tolerance of keyway width JS10.

Mounting

Internal freewheels FDN in standard type are without bearing support. Concentric alignment of inner and outer ring must be provided by the customer. The permissible run out (T.I.R.) must be observed.

The torque is transmitted on the outer ring by press fit. In order to transmit the torques specified in the table, the outer ring must be accommodated in a housing with an external diameter K. The housing is made of steel or grey cast iron in minimum quality GG-20. When using other housing materials or smaller external diameters, we urge you to contact us regarding the transmissible torque.

The tolerance of the housing bore D must be ISO P6 and the tolerance of the shaft must be ISO h6 or j6.

The permissible operating temperature of the freewheel is -40°C to 80°C.

Lubrication

An oil lubrication of the specified quality must be provided.

Example for ordering

Freewheel size FDN 30, standard type with 20 mm bore:

- FDN 30 CFH, d = 20 mm

Internal Freewheels FD

for press fit on the outer ring
with sprags

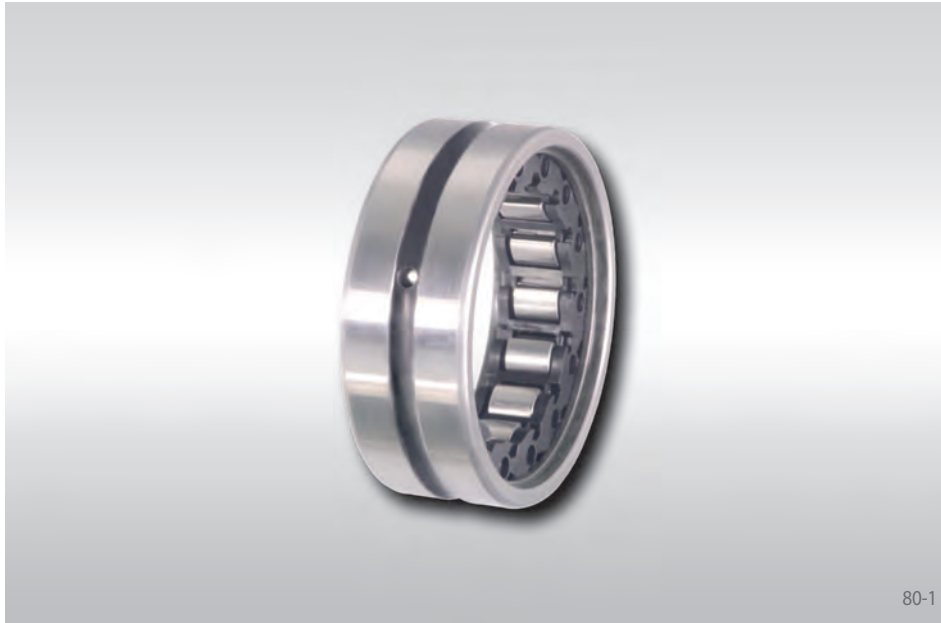

Application as

- ▶ Backstop
- ▶ Overrunning Clutch
- ▶ Indexing Freewheel

Features

Internal Freewheels FD are sprag freewheels without an inner ring. The customer's hardened and ground shaft is used as the inner track.

The standard type does not have bearing support. In the case of the standard type, every second sprag has been replaced by a cylindrical roller; this freewheel can accept radial forces.

Nominal torques up to 2400 Nm. The torque is transmitted on the outer ring by press fit.

Application example

Two Internal Freewheels FD 40 CFR of standard type with bearing support as overrunning clutches in the drive of the transport rollers in a packaging distribution unit. In normal operation, the transport rollers are driven by means of the freewheels that are working in driving operation. At the withdrawal station, the arriving packages can easily slip off as the drive is overrun by the freewheel (freewheeling operation).

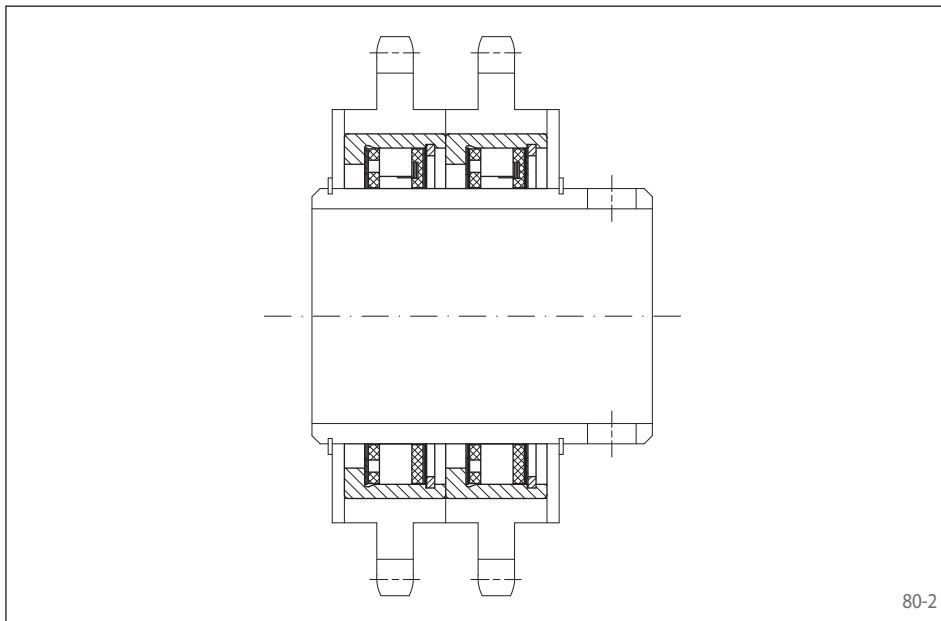

for press fit on the outer ring
with sprags

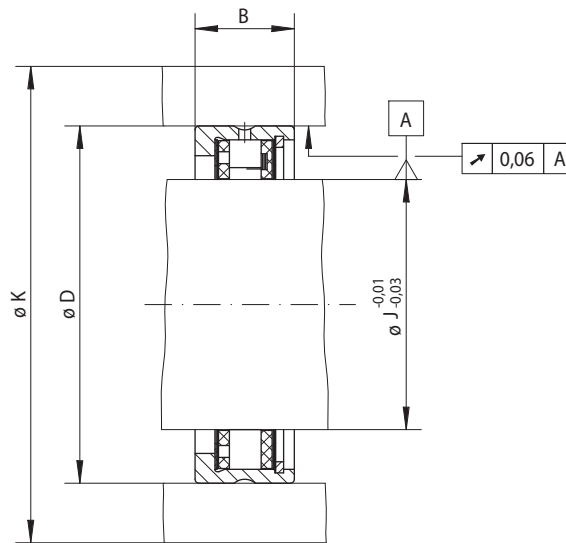

81-1

	Standard type For universal use	Standard type with bearing support For universal use	Dimensions
Indexing Freewheel			
Overrunning Clutch			
Backstop			

Freewheel Size	Type	Nominal torque M_N Nm	Max. speed		Type	Nominal torque M_N Nm	Max. speed		Load rating of bearing support		J mm	B mm	D mm	K mm	Weight kg
			Inner ring freewheels/ overruns min^{-1}	Outer ring freewheels/ overruns min^{-1}			Inner ring freewheels/ overruns min^{-1}	Outer ring freewheels/ overruns min^{-1}	dynamic C N	static C_0 N					
FD 12	CFH	11	4225	4250	CFR	6	4225	4250	7600	4200	12	16	34	45	0,1
FD 15	CFH	16	3875	3925	CFR	8	3875	3925	7800	4200	15	20	37	50	0,1
FD 20	CFH	28	3375	3450	CFR	14	3375	3450	8320	4200	20	20	42	55	0,1
FD 25	CFH	48	2900	3050	CFR	24	2900	3050	10700	5600	25	20	47	60	0,1
FD 30	CFH	75	2525	2675	CFR	36	2525	2675	12900	7000	30	20	52	65	0,1
FD 40	CFH	160	1900	2150	CFR	71	1900	2150	15000	8400	40	22	62	80	0,1
FD 50	CFH	260	1475	1775	CFR	120	1475	1775	18400	11300	50	22	72	95	0,2
FD 65	CFH	430	1200	1550	CFR	200	1200	1550	21400	14100	65	25	90	120	0,3
FD 80	CFH	650	950	1350	CFR	300	950	1350	23800	17800	80	25	110	140	0,6
FD 105	CFH	2400	800	1175	CFR	1100	800	1175	48600	45000	105	35	130	165	0,7

The maximum transmissible torque is 2 times the specified nominal torque. See page 14 for determination of selection torque.

The maximum speed values listed above apply to installation conditions as they are given for Complete Freewheels. If the actual installation conditions are known, higher speeds may be permitted under certain circumstances.

Mounting

Internal freewheels FD in type standard are without bearing support. Concentric alignment of inner and outer ring must be provided by the customer. The permissible run out (T.I.R.) must be observed.

The torque is transmitted on the outer ring by press fit. In order to transmit the torques specified in the table, the outer ring must be accommodated in a housing with an external diameter K. The housing is made of steel or grey cast iron in minimum quality GG-20. When using other housing materials or smaller external diameters, we urge you to contact us regarding the transmissible torque.

The tolerance of the housing bore D must be ISO P6.

Please note the technical points on page 106 regarding the sprag track (shaft).

The permissible operating temperature of the freewheel is -40°C to 80°C.

Lubrication

An oil lubrication of the specified quality must be provided.

Example for ordering

Freewheel size FD 12, standard type:

- FD 12 CFH

Internal Freewheels ZZ ...

with ball bearing properties

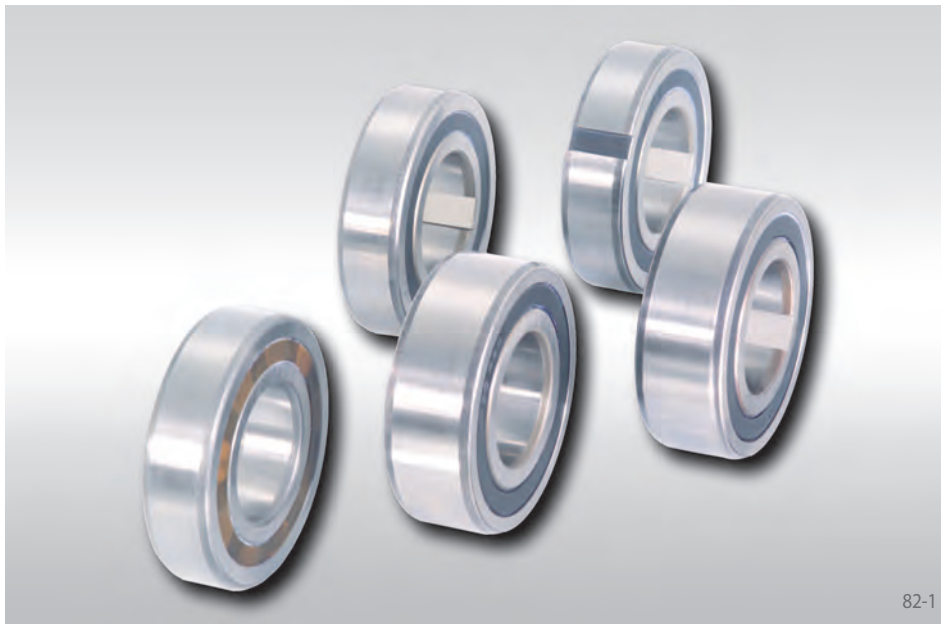

82-1

Application as

- ▶ Backstop
- ▶ Overrunning Clutch
- ▶ Indexing Freewheel

Features

Internal Freewheels ZZ ... are sprag freewheels with bearing support and ball bearing properties. The freewheels are supplied grease-filled for normal operating conditions.

The freewheel is built into the customer housing. This makes compact, space-saving fitting solutions possible.

Nominal torques up to 325 Nm. The torque is transmitted on the inner ring and/or on the outer ring by press fit or keyway connection.

Bores up to 40 mm.

The following series are available:

Series	Torque transmission on				ZRS-seals	Page
	Outer ring		Inner ring			
	by keyway	by press fit	by keyway	by press fit		
ZZ		●		●		83
ZZ ... 2RS		●		●	●	84
ZZ ... P2RS		●	●		●	85
ZZ ... P		●	●			86
ZZ ... PP	●		●			87

The Internal Freewheels ZZ of the sizes ZZ 6201 to ZZ 6207 have the same dimensions as the respective ball bearings of series 62.

The series ZZ ... 2RS and ZZ ... P2RS have 2RS seals.

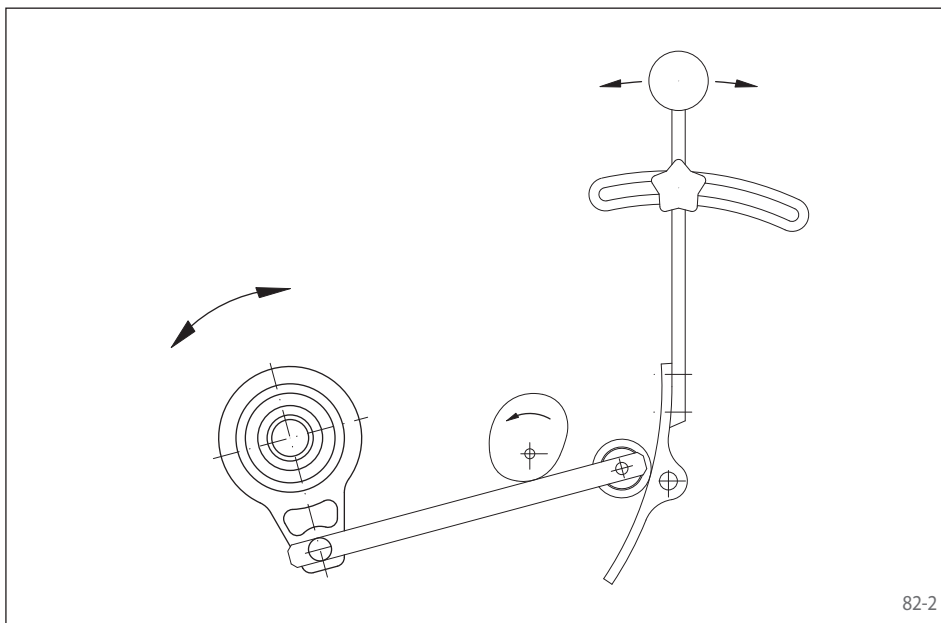

82-2

Application example

Two Internal Freewheels ZZ 6206 as indexing freewheels in the drive of the metering roller of a seed spreader. The freewheels are built in an infinitely variable oil bath gearbox. Two cam disks that are set off by 180° are arranged on the gearbox shaft. By means of lever arms, these drive the outer rings of the two adjacent Internal Freewheels, which then gradually turn the metering shaft. The infinite speed settings of the gearbox's drive shaft are executed by means of the respective pivoting of the roller support plate, so that the lever arms can execute lifts of differing amounts.

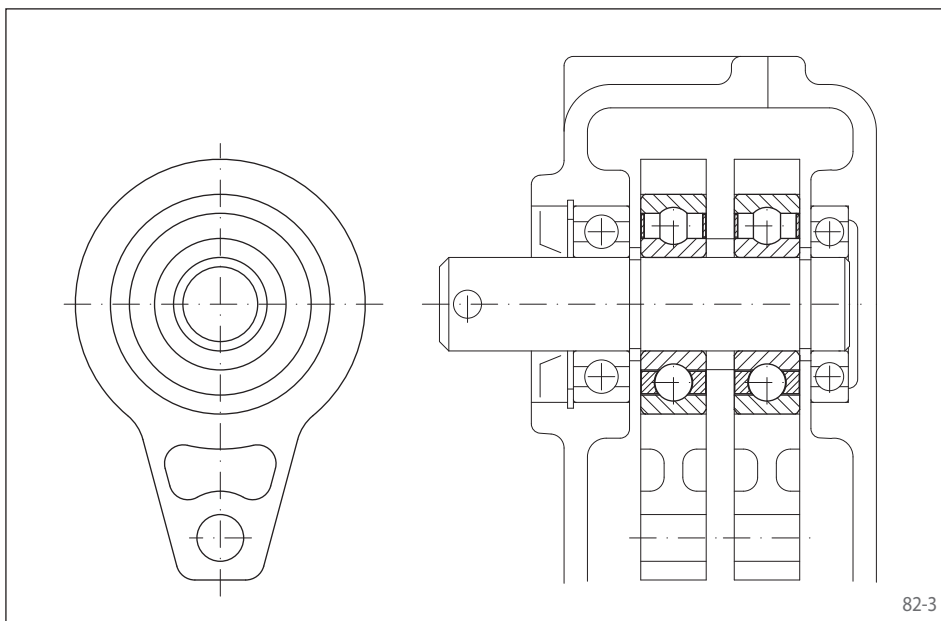

82-3

for press fit on the outer ring
with sprags and bearing support

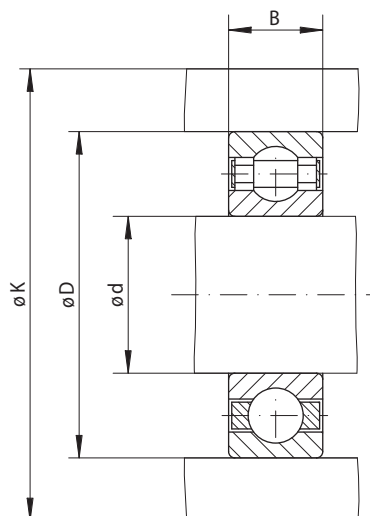

83-1

Indexing Freewheel Overrunning Clutch Backstop	Standard type For universal use	Dimensions

Freewheel Size	Nominal torque M_N Nm	Maximum speed min^{-1}	Load rating of bearing support		Bore d mm	B mm	D mm	K mm	Weight kg
			dynamic C N	static C_0 N					
ZZ 8	2,5	15 000	3 200	860	8	9	22	27	0,02
ZZ 6201	9,3	10 000	6 100	2 700	12	10	32	39	0,04
ZZ 6202	26,0	9 400	6 000	3 700	15	11	35	42	0,06
ZZ 6203	34,0	8 200	7 350	4 550	17	12	40	51	0,08
ZZ 6204	65,0	6 800	10 000	6 300	20	14	47	58	0,12
ZZ 6205	80,0	5 600	11 000	7 000	25	15	52	63	0,15
ZZ 6206	170,0	4 000	15 000	10 000	30	16	62	73	0,25
ZZ 6207	175,0	3 600	12 500	7 200	35	17	72	85	0,30
ZZ 40	325,0	3 000	15 500	12 250	40	22	80	94	0,50

■ Freewheels with bore diameters highlighted blue in the table are available with short delivery times.
The maximum transmissible torque is 2 times the specified nominal torque. See page 14 for determination of selection torque.

Mounting

The torque is transmitted on the inner and outer ring by press fit. In order to transmit the torques specified in the table, the outer ring must be accommodated in a housing with an external diameter K. The housing is made of steel or grey cast iron in minimum quality GG-20. When using other housing materials or smaller external diameters, we urge you to contact us regarding the transmissible torque.

The tolerance of the housing bore D must be ISO N6 and the tolerance of the shaft must be ISO n6.

The permissible operating temperature of the freewheel is -40°C to 80°C.

Lubrication

The freewheels are supplied grease-filled for normal operating conditions.

However, the freewheels can also be connected to the customer's oil lubrication system; this is particularly recommended in the case of higher speeds.

Example for ordering

Freewheel size ZZ 6202, standard type:

- ZZ 6202

for press fit on the outer ring
with sprags, bearing support and sealing

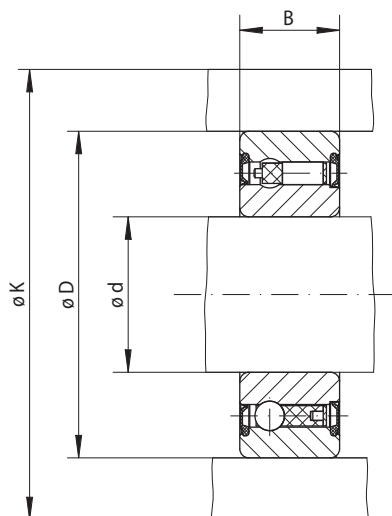

84-1

Indexing Freewheel Overrunning Clutch Backstop	Standard type For universal use	Dimensions

Freewheel Size	Nominal torque M_N Nm	Maximum speed min^{-1}	Load rating of bearing support		Bore d mm	B mm	D mm	K mm	Weight kg
			dynamic C N	static C_0 N					
ZZ 8 2RS*	2,5	15 000	3 300	860	8	9	22	27	0,02
ZZ 12 2RS	9,3	10 000	6 100	2 800	12	14	32	39	0,05
ZZ 15 2RS	17,0	8 400	7 400	3 400	15	16	35	42	0,07
ZZ 17 2RS	30,0	7 350	7 900	3 800	17	17	40	51	0,09
ZZ 20 2RS	50,0	6 000	9 400	4 500	20	19	47	58	0,15
ZZ 25 2RS	85,0	5 200	10 700	5 500	25	20	52	63	0,18
ZZ 30 2RS	138,0	4 200	11 700	6 500	30	21	62	73	0,27
ZZ 35 2RS	175,0	3 600	12 600	7 300	35	22	72	85	0,40
ZZ 40 2RS	325,0	3 000	15 500	12 300	40	27	80	94	0,60

■ Freewheels with bore diameters highlighted blue in the table are available with short delivery times.

The maximum transmissible torque is 2 times the specified nominal torque. See page 14 for determination of selection torque.

* Only one RS seal on the ball bearing side. Locking from this side the freewheeling direction of the innerring is clockwise free.

Mounting

The torque is transmitted on the inner and outer ring by press fit. In order to transmit the torques specified in the table, the outer ring must be accommodated in a housing with an external diameter K. The housing is made of steel or grey cast iron in minimum quality GG-20. When using other housing materials or smaller external diameters, we urge you to contact us regarding the transmissible torque.

The tolerance of the housing bore D must be ISO N6 and the tolerance of the shaft must be ISO n6.

The permissible operating temperature of the freewheel is +5°C to +60°C. Please contact us if the temperature is different to the given values.

Lubrication

The freewheels are supplied grease-filled and with 2 RS seals.

Example for ordering

Freewheel size ZZ 17 2RS, standard type:

- ZZ 17 2RS

for press fit on the outer ring
with sprags, bearing support and sealing

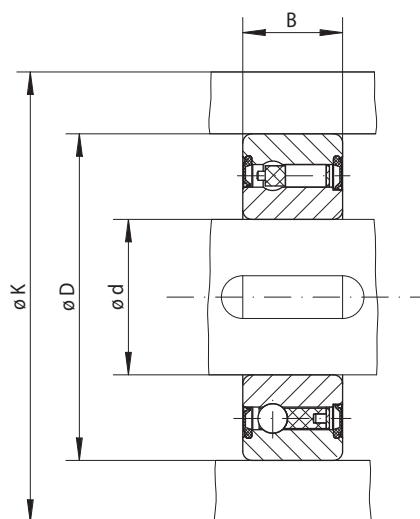

85-1

Indexing Freewheel Overrunning Clutch Backstop	Standard type For universal use	Dimensions

Freewheel Size	Nominal torque M_N Nm	Maximum speed min^{-1}	Load rating of bearing support		Bore d mm	B mm	D mm	K mm	Weight kg
			dynamic C N	static C_0 N					
ZZ 12 P2RS	9,3	10000	6100	2800	12	14	32	39	0,05
ZZ 15 P2RS	17,0	8400	7400	3400	15	16	35	42	0,07
ZZ 17 P2RS	30,0	7400	7900	3800	17	17	40	51	0,09
ZZ 20 P2RS	50,0	6000	9400	4500	20	19	47	58	0,15
ZZ 25 P2RS	85,0	5200	10700	5500	25	20	52	63	0,18
ZZ 30 P2RS	138,0	4200	11700	6500	30	21	62	73	0,30
ZZ 35 P2RS	175,0	3600	12600	7300	35	22	72	85	0,40
ZZ 40 P2RS	325,0	3000	15500	12300	40	27	80	94	0,60

Freewheels with bore diameters highlighted blue in the table are available with short delivery times.

The maximum transmissible torque is 2 times the specified nominal torque. See page 14 for determination of selection torque.

Keyway according to DIN 6885, page 3 • Tolerance of keyway width JS10.

Mounting

The torque is transmitted on the inner ring by keyway connection and on the outer ring by press fit. In order to transmit the torques specified in the table, the outer ring must be accommodated in a housing with an external diameter K. The housing is made of steel or grey cast iron in minimum quality GG-20. When using other housing materials or smaller external diameters, we urge you to contact us regarding the transmissible torque.

The tolerance of the housing bore D must be ISO N6 and the tolerance of the shaft must be ISO k6.

The permissible operating temperature of the freewheel is +5°C to +60°C. Please contact us if the temperature is different to the given values.

Lubrication

The freewheels are supplied grease-filled and with 2 RS seals.

Example for ordering

Freewheel size ZZ 25 P2RS, standard type:

- ZZ 25 P2RS

for press fit on the outer ring
with sprags and bearing support

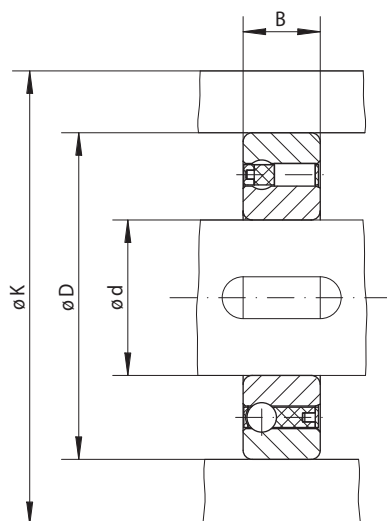

86-1

Indexing Freewheel Overrunning Clutch Backstop	Standard type For universal use	Dimensions

Freewheel Size	Nominal torque M_N Nm	Maximum speed min^{-1}	Load rating of bearing support		Bore d mm	B mm	D mm	K mm	Weight kg
			dynamic C N	static C_0 N					
ZZ 6201 P	9,3	10 000	6 100	2 800	12*	10	32	39	0,04
ZZ 6202 P	17	8 400	7 400	3 400	15*	11	35	42	0,06
ZZ 6203 P	30	7 350	7 900	3 800	17*	12	40	51	0,07
ZZ 6204 P	50	6 000	9 400	4 500	20*	14	47	58	0,11
ZZ 6205 P	85	5 200	10 700	5 500	25*	15	52	63	0,14
ZZ 6206 P	138	4 200	11 700	6 500	30*	16	62	73	0,21
ZZ 6207 P	175	3 600	12 600	7 300	35*	17	72	85	0,30
ZZ 40 P	325	3 000	15 500	12 300	40	22	80	94	0,50

Freewheels with bore diameters highlighted blue in the table are available with short delivery times.

The maximum transmissible torque is 2 times the specified nominal torque. See page 14 for determination of selection torque.

Keyway according to DIN 6885, page 1 • Tolerance of keyway width JS10.

* Keyway according to DIN 6885, page 3 • Tolerance of keyway width JS10.

Mounting

The torque is transmitted on the inner ring by keyway connection and on the outer ring by press fit. In order to transmit the torques specified in the table, the outer ring must be accommodated in a housing with an external diameter K. The housing is made of steel or grey cast iron in minimum quality GG-20. When using other housing materials or smaller external diameters, we urge you to contact us regarding the transmissible torque.

The tolerance of the housing bore D must be ISO N6 and the tolerance of the shaft must be ISO k6.

The permissible operating temperature of the freewheel is +5°C to +60°C. Please contact us if the temperature is different to the given values.

Lubrication

The freewheels are supplied grease-filled.

Example for ordering

Freewheel size ZZ 6203 P, standard type:

- ZZ 6203 P

Internal Freewheels ZZ ... PP

for keyway connection on the outer ring
with sprags and bearing support

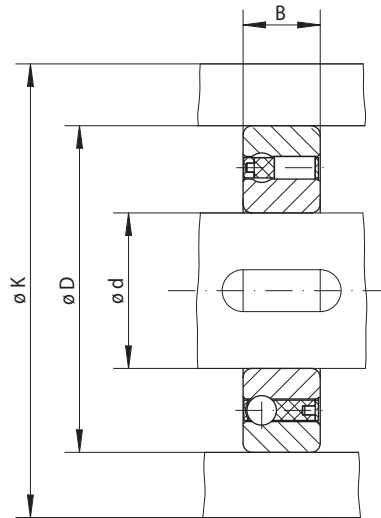
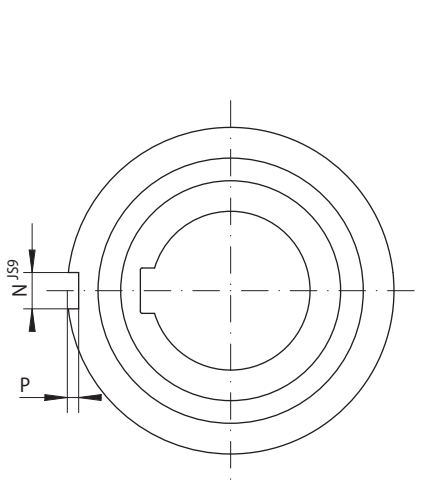

87-1

87-2

Indexing Freewheel Overrunning Clutch Backstop	Standard type For universal use	Dimensions

Freewheel Size	Nominal torque M_N Nm	Maximum speed min^{-1}	Load rating of bearing support		Bore d mm	B mm	D mm	K mm	N mm	P mm	Weight kg
			dynamic C N	static C_0 N							
ZZ 6202 PP	17	8400	7400	3400	15*	11	35	42	2	0,6	0,06
ZZ 6203 PP	30	7350	7900	3800	17*	12	40	51	2	1,0	0,07
ZZ 6204 PP	50	6000	9400	4500	20*	14	47	58	3	1,5	0,11
ZZ 6205 PP	85	5200	10700	5500	25*	15	52	63	6	2,0	0,14
ZZ 6206 PP	138	4200	11700	6500	30*	16	62	73	6	2,0	0,21
ZZ 6207 PP	175	3600	12600	7300	35*	17	72	85	8	2,5	0,30
ZZ 40 PP	325	3000	15500	12300	40	22	80	94	10	3,0	0,50

■ Freewheels with bore diameters highlighted blue in the table are available with short delivery times.
 The maximum transmissible torque is 2 times the specified nominal torque. See page 14 for determination of selection torque.
 Keyway according to DIN 6885, page 1 • Tolerance of keyway width JS10.
 * Keyway according to DIN 6885, page 3 • Tolerance of keyway width JS10.

Mounting

The torque is transmitted on the inner and on the outer ring by keyway connection. In order to transmit the torques specified in the table, the outer ring must be accommodated in a housing with an external diameter K. The housing is made of steel or grey cast iron in minimum quality GG-20. When using other housing materials or smaller external diameters, we urge you to contact us regarding the transmissible torque.

The tolerance of the housing bore D must be ISO H6 and the tolerance of the shaft must be ISO h6.

The permissible operating temperature of the freewheel is +5°C to +60°C. Please contact us if the temperature is different to the given values.

Lubrication

The freewheels are supplied grease-filled.

Example for ordering

Freewheel size ZZ 6205 PP, standard type:

- ZZ 6205 PP

Internal Freewheels FSN

for keyway connection on the outer ring
with rollers

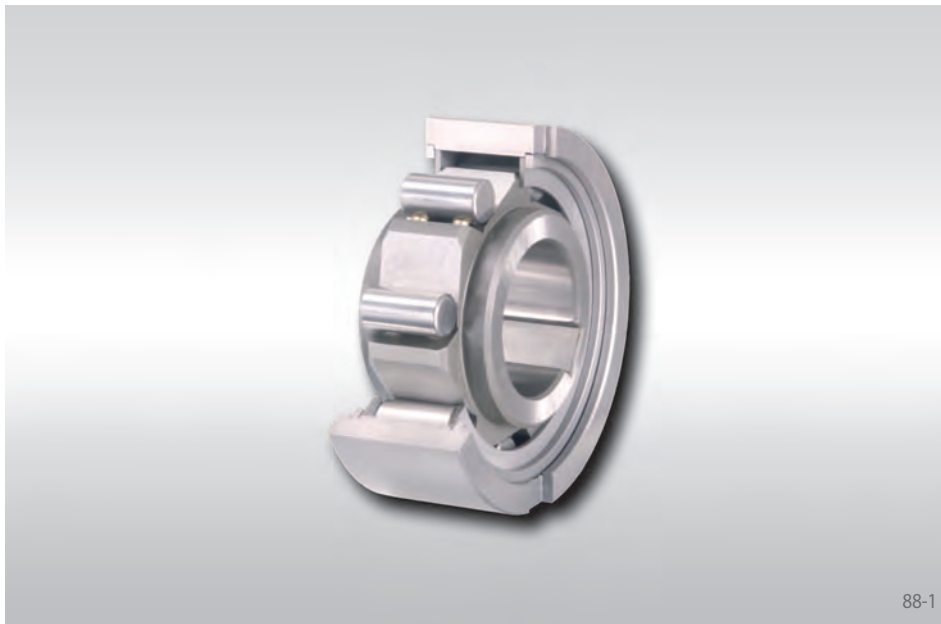

Application as

- ▶ Backstop
- ▶ Overrunning Clutch
- ▶ Indexing Freewheel

Features

Internal Freewheels FSN are roller freewheels without bearing support.

The freewheel is built into the customer housing. This makes compact, space-saving fitting solutions possible.

Nominal torques up to 3 000 Nm. The faces of both sides of the outer ring are provided with grooves for torque transmission.

Bores up to 80 mm.

88-1

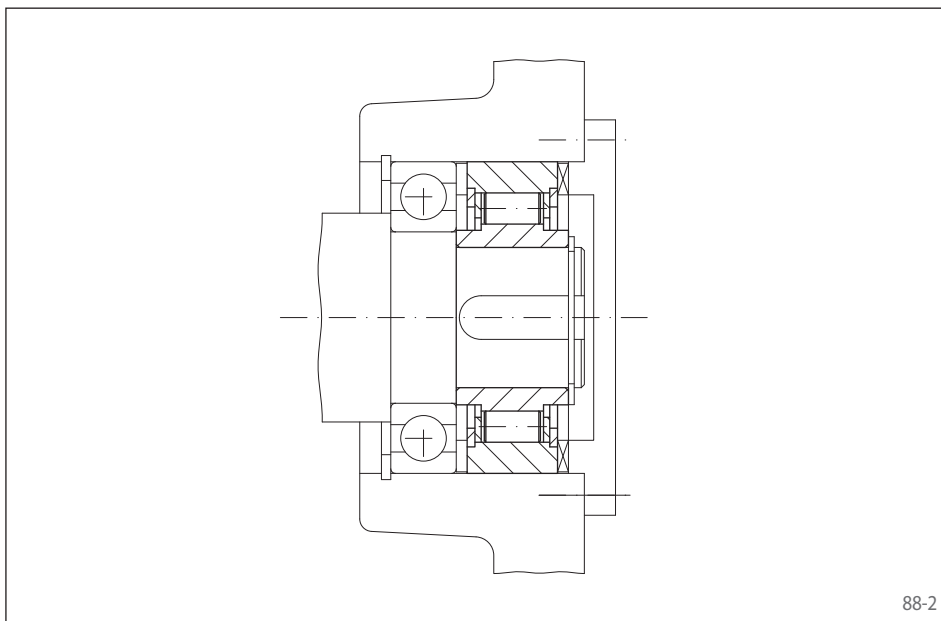

Application example

Internal freewheel FSN 50 as backstop fitted to the end of the intermediate shaft of a spur gearbox in the drive of an elevator. In the case of a motor stop, the elevator must be held securely so that the conveyor goods do not pull backwards.

88-2

for keyway connection on the outer ring
with rollers

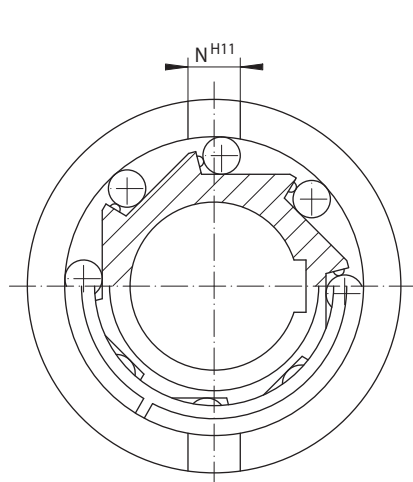

89-1

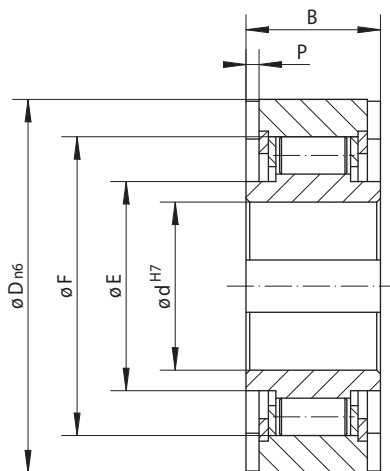

89-2

Indexing Freewheel Overrunning Clutch Backstop	Standard type For universal use	Dimensions

Freewheel Size	Nominal torque M_N Nm	Max. speed		Bore d mm	B mm	D mm	E mm	F mm	N mm	P mm	Weight kg
		Inner ring freewheels/overruns min^{-1}	Outer ring freewheels/overruns min^{-1}								
FSN 8	11	3050	4700	8	13	35	18,5	28	4	1,3	0,1
FSN 12	11	3050	4700	12	13	35	18,5	28	4	1,3	0,1
FSN 15	36	2350	3700	15*	18	42	21,0	36	5	1,7	0,1
FSN 17	56	2100	3300	17*	19	47	24,0	40	5	2,0	0,2
FSN 20	90	1750	3200	20*	21	52	29,0	45	6	1,5	0,2
FSN 25	125	1650	3100	25*	24	62	35,0	52	8	2,0	0,4
FSN 30	210	1400	2200	30*	27	72	40,0	60	10	2,5	0,6
FSN 35	306	1250	2150	35*	31	80	47,0	68	12	3,5	0,8
FSN 40	430	1100	2050	40*	33	90	55,0	78	12	3,5	0,9
FSN 45	680	1000	1900	45*	36	100	56,0	85	14	3,5	1,3
FSN 50	910	900	1750	50*	40	110	60,0	92	14	4,5	1,7
FSN 60	1200	750	1450	60*	46	130	75,0	110	18	5,5	2,8
FSN 70	2000	600	1000	70*	51	150	85,0	125	20	6,5	4,2
FSN 80	3000	500	900	80*	58	170	95,0	140	20	7,5	6,0

Freewheels with bore diameters highlighted blue in the table are available with short delivery times.

The maximum transmissible torque is 2 times the specified nominal torque. See page 14 for determination of selection torque.

Keyway according to DIN 6885, page 1 • Tolerance of keyway width JS10.

* Keyway according to DIN 6885, page 3 • Tolerance of keyway width JS10.

Mounting

Internal Freewheels FSN are without bearing support. Concentric alignment of inner and outer ring must be provided by the customer.

The tolerance of the housing bore D must be ISO H7 or G7 and the tolerance of the shaft must be ISO h6 or j6.

The outer ring has to be completely enclosed in a stable housing to transmit the listed torques.

Lubrication

An oil lubrication of the specified quality must be provided.

Example for ordering

Freewheel size FSN 12, standard type:

- FSN 12

Internal Freewheels FN

for keyway connection on the outer ring
with rollers

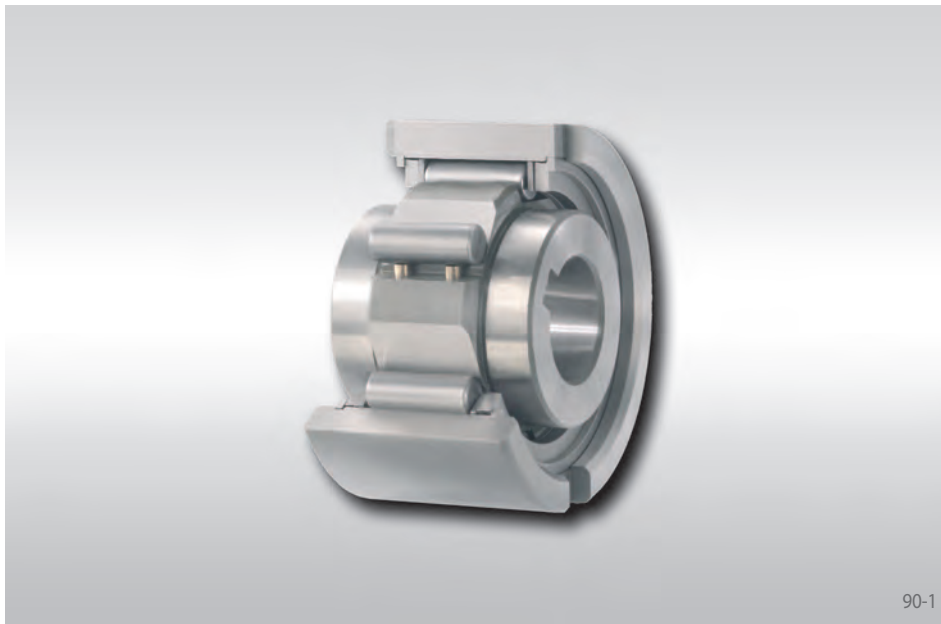

90-1

Application as

- ▶ Backstop
- ▶ Overrunning Clutch
- ▶ Indexing Freewheel

Features

Internal Freewheels FN are roller freewheels without bearing support.

The freewheel is built into the customer housing. This makes compact, space-saving fitting solutions possible.

Nominal torques up to 3 000 Nm. The faces of both sides of the outer ring are provided with grooves for torque transmission.

Bores up to 60 mm.

Application example

Internal freewheel FN 20 as a backstop, on the drive shaft of running gears on a chain conveyor. In normal operation, the drive shaft drives and the freewheel works in freewheeling operation. The freewheel as a backstop prevents the running gears from being able to run backwards uncontrolled in the event of a fault.

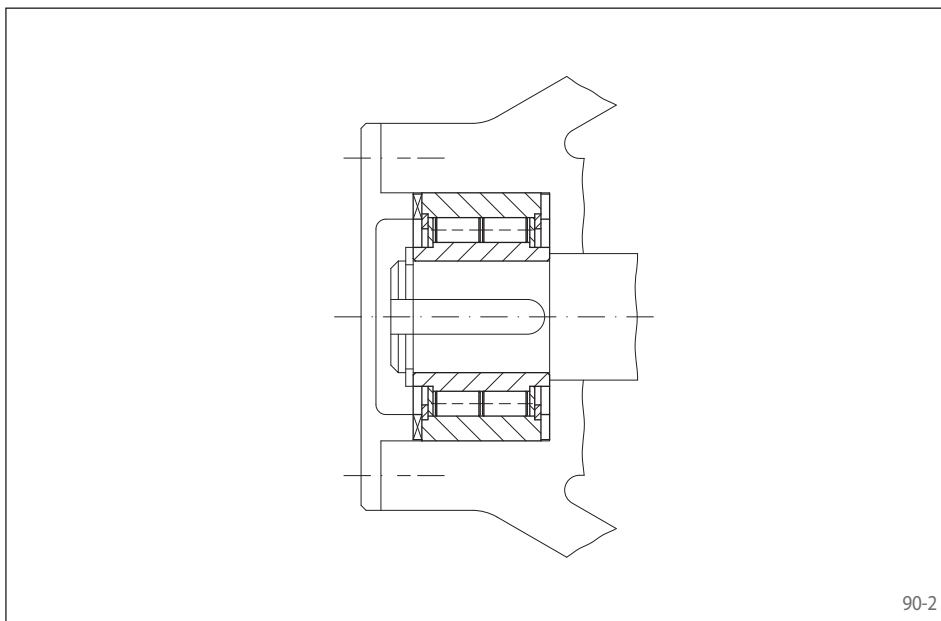

90-2

Internal Freewheels FN

for keyway connection on the outer ring
with rollers

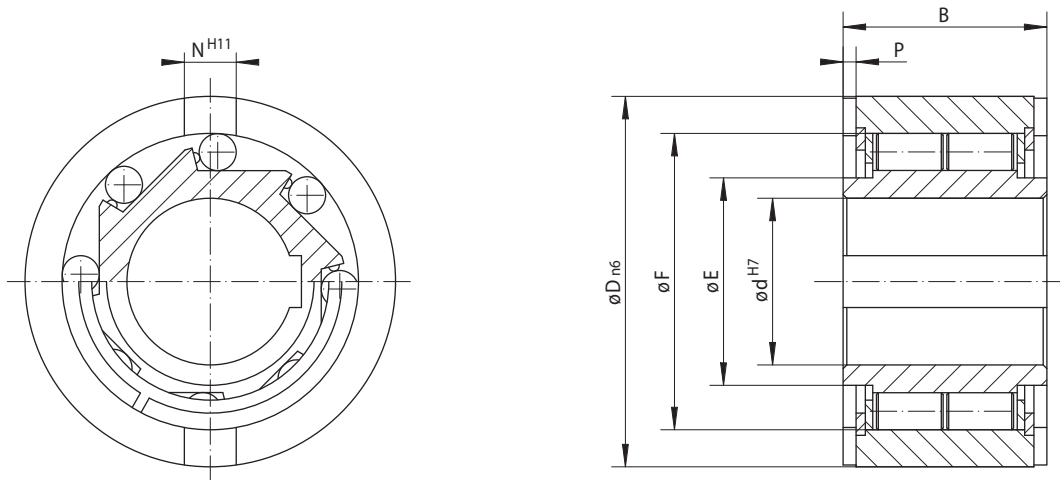

91-1

91-2

Indexing Freewheel Overrunning Clutch Backstop	Standard type For universal use	Dimensions

Freewheel Size	Nominal torque M_N Nm	Max. speed		Bore d mm	B mm	D mm	E mm	F mm	N mm	P mm	Weight kg
		Inner ring freewheels/ overruns min^{-1}	Outer ring freewheels/ overruns min^{-1}								
FN 8	18	2800	5400	8	20	37	19	30	6	3,0	0,1
FN 12	18	2800	5400	12	20	37	19	30	6	3,0	0,1
FN 15	50	2500	5100	15	30	47	23	37	7	3,5	0,3
FN 20	112	1900	4350	20	36	62	35	50	8	3,5	0,6
FN 25	220	1550	3350	25	40	80	40	68	9	4,0	1,1
FN 30	410	1400	3050	30	48	90	45	75	12	5,0	1,6
FN 35	500	1300	2850	35	53	100	50	80	13	6,0	2,3
FN 40	750	1150	2500	40	63	110	55	90	15	7,0	3,1
FN 45	1020	1100	2400	45	63	120	60	95	16	7,0	3,7
FN 50	1900	950	2050	50	80	130	70	110	17	8,5	5,3
FN 55	2000	900	1900	55	80	140	75	115	18	9,0	6,0
FN 60	3000	800	1800	60	95	150	80	125	18	9,0	8,4

■ Freewheels with bore diameters highlighted blue in the table are available with short delivery times.
The maximum transmissible torque is 2 times the specified nominal torque. See page 14 for determination of selection torque.
Keyway according to DIN 6885, page 1 • Tolerance of keyway width JS10.

Mounting

Internal Freewheels FN are without bearing support. Concentric alignment of inner and outer ring must be provided by the customer.

The tolerance of the housing bore D must be ISO H7 or G7 and the tolerance of the shaft must be ISO h6 or j6.

The outer ring has to be completely enclosed in a stable housing to transmit the listed torques.

Lubrication

An oil lubrication of the specified quality must be provided.

Example for ordering

Freewheel size FN 45, standard type:

- FN 45

Internal Freewheels FNR

for keyway connection on the outer ring
with rollers and bearing

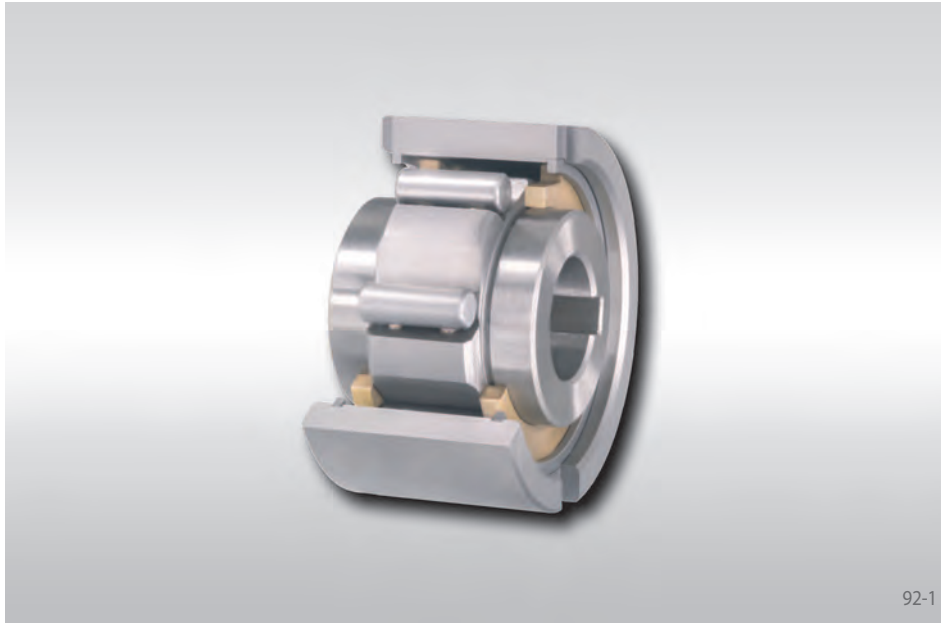

92-1

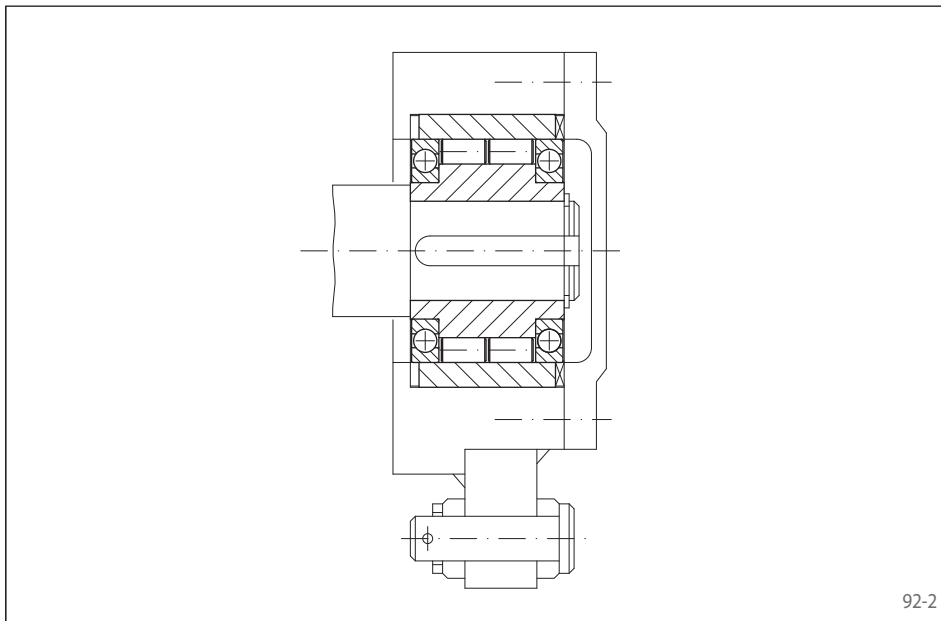

92-2

Application as

- ◆ Backstop
- ◆ Overrunning Clutch
- ◆ Indexing Freewheel

Features

Internal Freewheels FNR are roller freewheels with bearing support. The freewheels of sizes 8 to 20 have a sleeve bearing. The sizes 25 to 60 have ball bearings, these enable higher speeds in freewheeling operation.

The freewheel is built into the customer housing. This makes compact, space-saving fitting solutions possible.

Nominal torques up to 3000 Nm. The faces of both sides of the outer ring are provided with grooves for torque transmission.

Bores up to 60 mm.

Application example

Internal Freewheel FNR 40 as an indexing freewheel for an incremental drive in the feeding device of a wire processing machine. The indexing lever is driven by a crank operation. The back and forth movement is transferred by the indexing freewheel in a gradual rotating movement of the wire feeding device.

Internal Freewheels FNR

for keyway connection on the outer ring
with rollers and bearing

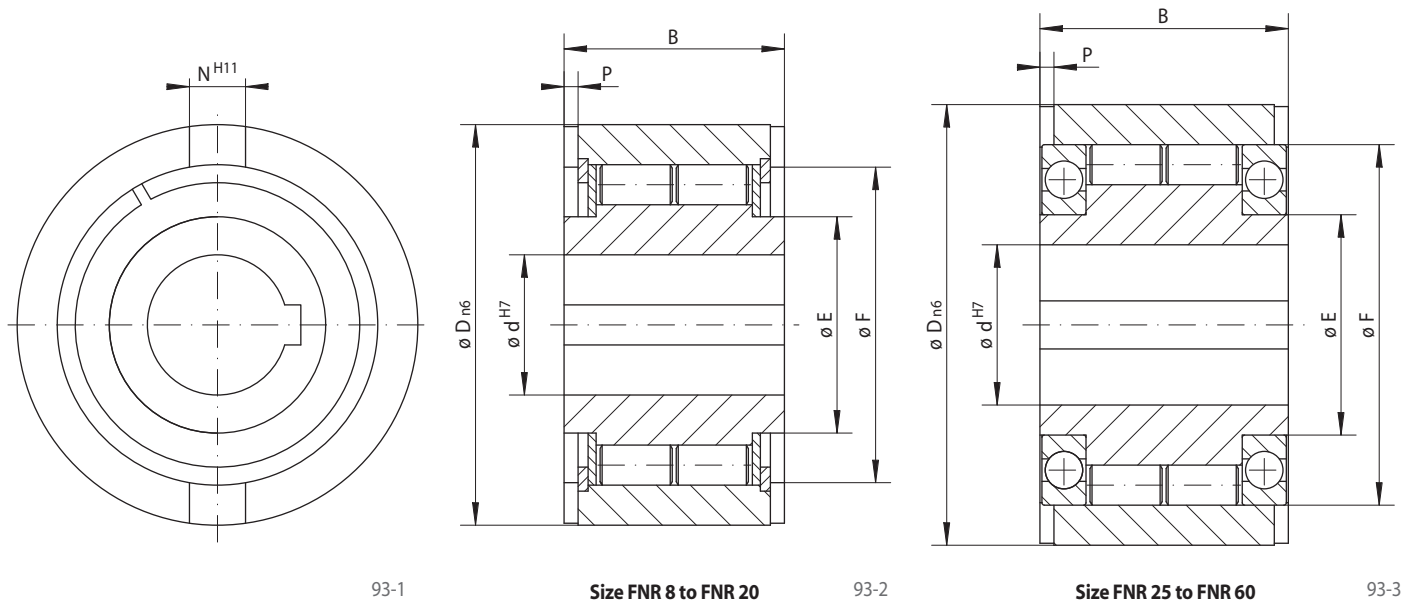

Indexing Freewheel Overrunning Clutch Backstop	Standard type For universal use	Dimensions

Freewheel Size	Nominal torque M_N Nm	Max. speed		Bore d mm	B mm	D mm	E mm	F mm	N mm	P mm	Weight kg
		Inner ring freewheels/overruns min ⁻¹	Outer ring freewheels/overruns min ⁻¹								
FNR 8	18	1200	1200	8	20	37	19	30	6	3,0	0,1
FNR 12	18	1200	1200	12	20	37	19	30	6	3,0	0,1
FNR 15	50	950	950	15	30	47	23	37	7	3,5	0,3
FNR 20	112	650	650	20	36	62	35	50	8	3,5	0,6
FNR 25	220	1550	3350	25	40	80	40	68	9	4,0	1,3
FNR 30	410	1400	3050	30	48	90	45	75	12	5,0	1,9
FNR 35	500	1300	2850	35	53	100	50	80	13	6,0	2,6
FNR 40	750	1150	2500	40	63	110	55	90	15	7,0	3,6
FNR 45	1020	1100	2400	45	63	120	60	95	16	7,0	4,2
FNR 50	1900	950	2050	50	80	130	70	110	17	8,5	6,0
FNR 55	2000	900	1900	55	80	140	75	115	18	9,0	6,8
FNR 60	3000	800	1800	60	95	150	80	125	18	9,0	9,5

■ Freewheels with bore diameters highlighted blue in the table are available with short delivery times.
The maximum transmissible torque is 2 times the specified nominal torque. See page 14 for determination of selection torque.
Keyway according to DIN 6885, page 1 • Tolerance of keyway width JS10.

Mounting

The tolerance of the housing bore D must be ISO H7 or G7 and the tolerance of the shaft must be ISO h6 or j6.

The outer ring has to be completely enclosed in a stable housing to transmit the listed torques.

Lubrication

An oil lubrication of the specified quality must be provided.

Example for ordering

Freewheel size FNR 20, standard type:
• FNR 20

Cage Freewheels SF

for assembly with inner and outer ring
with sprags, available in three types



Application as

- ▶ Backstop
- ▶ Overrunning Clutch
- ▶ Indexing Freewheel

Features

Cage Freewheels SF are sprag freewheels to be installed between customer-supplied inner and outer rings.

In addition to the standard type, two other types are available for extended service life.

Nominal torques up to 93 000 Nm.

Mounting

The lateral guidance of the Cage Freewheels can be effected either by a shoulder on the outer ring or by guard rings or guard discs which are fixed in the outer ring.

Torque transmission capacity can be increased if several cages are arranged side by side. In this case please consult with RINGSPANN on transmissible torques.

Please note the technical points on page 106 regarding the sprag tracks.

Example for ordering

Freewheel size SF 44-14,5, standard type:

- SF 44-14,5 K

Cage Freewheels SF

for assembly with inner and outer ring
with sprags, available in three types

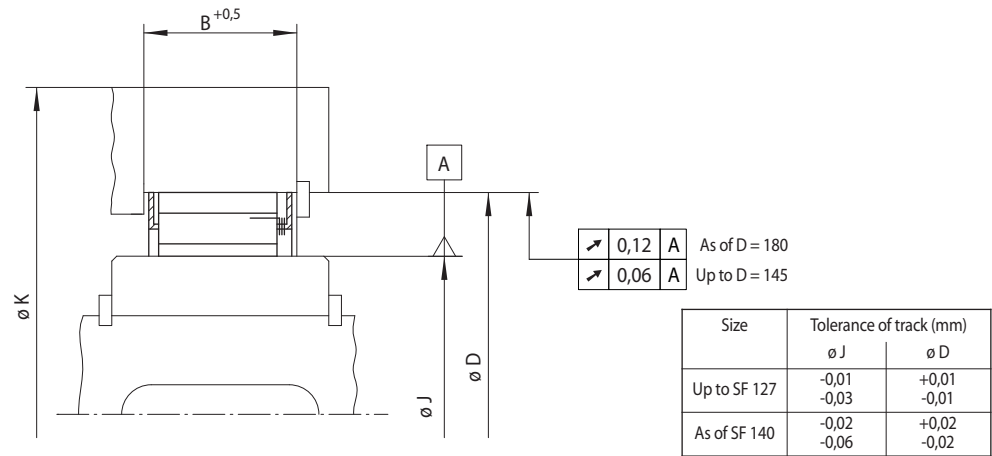

95-2

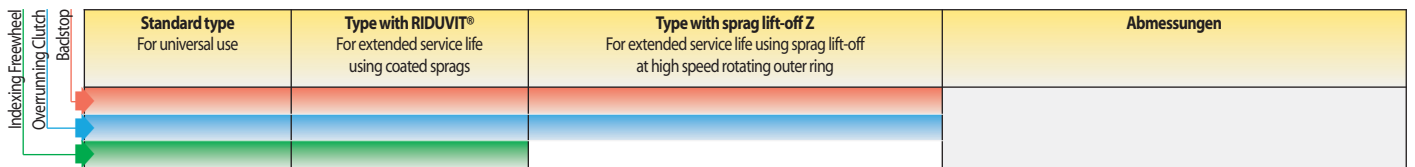

Freewheel Size	Type	Nominal torque M_N Nm	Type	Nominal torque M_N Nm	Type	Nominal torque M_N Nm	Sprag lift-off at outer ring speed min^{-1}	Max. speed Inner ring drives min^{-1}	J	D	B	K	Sprags	Weight kg
									mm	mm	mm	mm	Quantity	
SF 18-13,5	J	66							18,80	35,47	13,5	50	10	0,04
SF 23-13,5	J	120							23,63	40,29	13,5	55	12	0,04
SF 27-13,5	J	160	JT	160	JZ	100	3600	1440	27,78	44,42	13,5	65	14	0,05
SF 31-13,5	J	170	JT	170	JZ	110	3400	1360	31,75	48,41	13,5	70	12	0,04
SF 32-21,5	J	400							32,77	49,44	21,5	65	14	0,07
SF 37-14,5	K	270	KT	270	KZ	210	2900	1160	37	55	14,5	75	14	0,06
SF 42-21	J	720							42,10	58,76	21	85	18	0,09
SF 44-14,5	K	500	KT	500	KZ	400	2250	900	44	62	14,5	90	20	0,08
SF 46-21	J	840							46,77	63,43	21	90	20	0,10
SF 50-18,5	K	680	KT	680	KZ	580	2250	900	50	68	18,5	90	20	0,10
SF 56-21	J	1050							56,12	72,78	21	100	22	0,11
SF 57-18,5	K	950	KT	950	KZ	800	2000	800	57	75	18,5	105	24	0,13
SF 61-21	J	1300	JT	1300	JZ	1150	1550	620	61,91	78,57	21	110	26	0,14
SF 72-23,5	K	2100	KT	2100	KZ	1850	1550	620	72	90	23,5	135	32	0,23
SF 82-25	K	2300	KT	2300	KZ	2100	1450	580	82	100	25	140	36	0,26
SF 107-25	K	3300	KT	3300	KZ	3100	1300	520	107	125	25	170	48	0,35
SF 127-25	K	4900	KT	4900	KZ	4600	1200	480	127	145	25	210	56	0,40
SF 140-50	S	13600	ST	13600	SZ	10500	950	380	140	180	50	260	24	1,70
SF 140-63	S	18000	ST	18000	SZ	14000	800	320	140	180	63	260	24	2,00
SF 170-50	S	17000	ST	17000	SZ	13500	880	352	170	210	50	290	28	1,95
SF 170-63	S	23000	ST	23000	SZ	18500	720	288	170	210	63	290	28	2,40
SF 200-50	S	23000	ST	23000	SZ	18500	820	328	200	240	50	325	36	2,50
SF 200-63	S	29000	ST	29000	SZ	23500	680	272	200	240	63	325	36	3,10
SF 230-63	S	37000	ST	37000	SZ	29500	650	260	230	270	63	360	45	3,90
SF 270-50	S	35000	ST	35000	SZ	29500	720	288	270	310	50	410	48	3,40
SF 270-63	S	44000	ST	44000	SZ	37000	600	240	270	310	63	410	48	4,20
SF 340-50	S	45000	ST	45000	SZ	43000	640	256	340	380	50	510	60	4,20
SF 340-63	S	67500	ST	67500	SZ	57500	540	216	340	380	63	510	60	5,20
SF 380-50	S	57000	ST	57000	SZ	48500	610	244	380	420	50	550	63	4,40
SF 440-63	S	93000	ST	93000	SZ	80000	470	188	440	480	63	640	72	6,20

The theoretical nominal torque applies only for ideal concentricity between the inner and outer ring.
 The maximum transmissible torque is 2 times the specified nominal torque. See page 14 for determination of selection torque.

Cage Freewheels SF ... P

for assembly with inner and outer ring
for high run out (T.I.R.), with sprags



Application as

- ▶ Backstop
- ▶ Overrunning Clutch
- ▶ Indexing Freewheel

Features

Cage Freewheels SF ... P are sprag freewheels to be installed between customer-supplied inner and outer rings.

Nominal torques up to 5 800 Nm.

96-1

Cage Freewheels SF ... P

for assembly with inner and outer ring
for high run out (T.I.R.), with sprags

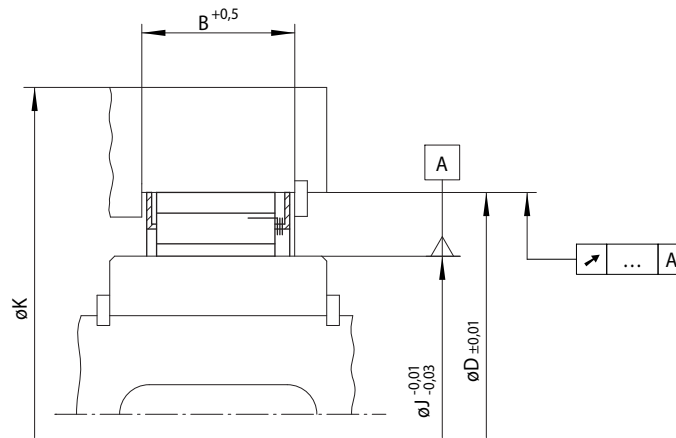

97-2

		Type for high run out (T.I.R.) For universal use				Dimensions					
						J	D	B	K	Sprags	Weight
Freewheel Size	Type	Theoretical nominal torque ↗ 0,0 A Nm	Nominal torque at existing run out (T.I.R.)			mm	mm	mm	mm	Quantity	kg
			↗ 0,05 A Nm	↗ 0,1 A Nm	↗ 0,15 A Nm						
SF 37-14,5	P	230	210	200	200	37,00	55,00	14,5	75	14	0,06
SF 44-14,5	P	420	390	360	350	44,00	62,00	14,5	90	20	0,08
SF 57-18,5	P	1 200	960	750	600	57,00	75,00	18,5	100	24	0,13
SF 72-23,5	P	2 700	2 200	1 700	1 400	72,00	90,00	23,5	130	32	0,23
SF 82-25	P	2 800	2 400	1 900	1 500	82,00	100,00	25,0	135	36	0,26
SF 107-25	P	4 100	3 300	2 700	2 100	107,00	125,00	25,0	165	48	0,35
SF 127-25	P	5 800	4 800	3 900	3 100	127,00	145,00	25,0	200	56	0,40

The maximum transmissible torque is 2 times the specified nominal torque. See page 14 for determination of selection torque.
The theoretical nominal torque applies only for ideal concentricity between the inner and outer ring. In practice, the concentricity is affected by the bearing play and centering errors of the neighbouring parts. Then the nominal torques specified in the table apply, whilst taking into consideration the existing run out (T.I.R.).

Mounting

The lateral guidance of the Cage Freewheels can be effected either by a shoulder on the outer ring or by guard rings or guard discs which are fixed in the outer ring.

Torque transmission capacity can be increased if several cages are arranged side by side. In this case please consult with RINGSPANN on transmissible torques.

Please note the technical points on page 106 regarding the sprag tracks.

Example for ordering

Freewheel size SF 44-14,5 type for high run out (T.I.R.):

- SF 44-14,5 P

Cage Freewheels BWX

for assembly with inner and outer ring
with sprags



98-1

Mounting

The lateral guidance of the Cage Freewheels can be effected either by a shoulder on the outer ring or by guard rings or guard discs which are fixed in the outer ring. There must be no undercuts, recesses, shoulders or chamfers, or any eccentricity whatsoever, over dimension „B“. For ease of assembly we recommend that the inner and outer races be chamfered at an angle of 15 degrees for a length of 3 mm.

Please note the technical points on page 106 regarding the sprag tracks.

Application as

- ▶ Backstop
- ▶ Overrunning Clutch
- ▶ Indexing Freewheel

Features

Cage Freewheels BWX are sprag freewheels to be installed between customer-supplied inner and outer rings.

Nominal torques up to 4 900 Nm.

Disengaging

When the outer ring is rotating the centrifugal force causes the sprags to lift off from the inner race. This reduces wear during freewheeling operation.

Engaging

When the outer ring is rotating the centrifugal force presses the sprags against the inner ring. This enhances the ability of the sprags to engage immediately when torque is applied.

Drag strips

To reduce wear during freewheeling operation between sprags and the inner race, drag strips made from wear-resistant beryllium copper alloy are attached to the inner cage. This results in increased friction between inner cage and inner race. This counteracts individual sprag activation during freewheeling operation, thereby greatly reducing sprag pressure on the inner race.

Brake clips

Some freewheel sizes are available with brake clips fitted on the outer cage to prevent further automatic rotation of the Cage Freewheel during rapid acceleration and deceleration of the outer ring (e.g. in indexing freewheels).

Cage Freewheels BWX

for assembly with inner and outer ring
with sprags

When viewing in direction X
the outer ring freewheels clockwise

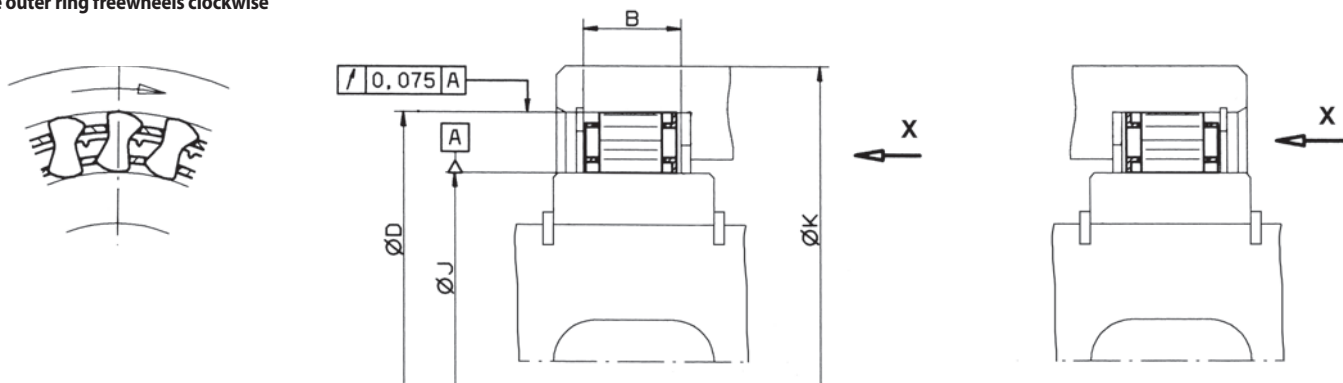

99-1

99-2

99-3

Indexing Freewheel Overrunning Clutch Bedstop	Standard type For universal use	Dimensions									
	Indexing Freewheel										
Overrunning Clutch											
Bedstop											

Freewheel Size	Type	Nominal torque M_N Nm	J +0,008 -0,005 mm	D $\pm 0,013$ mm	B min. mm	K mm	Sprags	Drag strips	Brake clips	Design as ill.	Weight kg
							Quantity	Quantity	Quantity		
BWX 133590A	Disengaging	63	22,225	38,887	10,0	44,0	12			99-2	0,03
BWX 13143A	Engaging	120	27,767	44,425	13,5	51,0	14			99-2	0,06
BWX 133392	Disengaging	280	38,092	54,750	16,0	71,0	18			99-3	0,09
BWX 1310145	Disengaging	180	41,275	57,937	13,5	74,2	14		3	99-2	0,07
BWX 132909A	Disengaging	360	44,450	61,112	16,0	78,5	20	2	3	99-2	0,10
BWX 133339	Disengaging	310	49,721	66,383	13,5	85,0	22	2	4	99-2	0,09
BWX 1310003	Disengaging	310	49,721	66,383	13,5	85,0	22		4	99-2	0,09
BWX 137222	Engaging	570	49,721	66,383	19,0	85,0	22			99-2	0,12
BWX 1310445	Disengaging	400	54,765	71,427	13,5	91,7	24			99-2	0,09
BWX 1310172	Engaging	540	54,765	71,427	16,0	91,7	24			99-2	0,12
BWX 1310226	Disengaging	520	54,765	71,427	16,0	91,7	24	2	4	99-2	0,12
BWX 136709	Engaging	770	54,765	71,427	21,0	91,7	24	3	10	99-2	0,16
BWX 1310147	Disengaging	1000	54,765	71,427	25,4	91,7	24	3	8	99-2	0,20
BWX 136324	Engaging	600	57,760	74,427	19,0	95,0	26			99-3	0,14
BWX 1310080	Disengaging	670	72,217	88,882	13,5	115,0	30		4	99-2	0,12
BWX 13168	Engaging	1300	72,217	88,882	21,0	115,0	30			99-3	0,20
BWX 134012	Engaging	1300	72,217	88,882	21,0	115,0	30	4	10	99-3	0,20
BWX 137322	Disengaging	2000	79,698 ²	96,363	25,4	124,0	34	5	12	99-2	0,28
BWX 138316	Disengaging	2960	83,597 ²	102,596	25,4	131,6	34	5	12	99-2	0,30
BWX 13261A ¹	Disengaging	1600	103,231 ²	119,893	16,0	154,0	40	6	10	99-3	0,19
BWX 13236	Disengaging	1700	117,391 ²	136,391	16,0	175,3	30	5	6	99-3	0,25
BWX 133403B	Engaging	4900	123,881 ²	142,880	25,4	188,0	44		11	99-2	0,46

¹ With this Freewheel Size the centering flange of the inner cage is on the right hand side!

² Tolerance of the inner ring race diameter may be increased by $\pm 0,013$ mm!

The theoretical nominal torque applies only for ideal concentricity between the inner and outer ring.

The maximum transmissible torque is 2 times the specified nominal torque. See page 14 for determination of selection torque.

Example for ordering

Freewheel size BWX 13143A, standard type:

- BWX 13143A

bidirectional acting backstop for assembly with connecting parts with rollers



Application as

- ▶ Bidirectional Acting Backstop

Features

Irreversible Locks IR are bidirectional acting roller freewheels with bearing support. They are ready for installation.

Nominal torques up to 100 Nm.

Bores up to 35 mm.

Whereas a normal Freewheel transmits torques from the driving or driven side in only one direction of rotation, with the Irreversible Lock IR it is possible for the driving part to drive the shaft in both directions of rotation. There is, however, a locking action against any reverse torque coming from the driven part, irrespective of the direction of rotation in which it is exerted.

Operation

The centre body (1) is positively locked to the shaft (driven part) by a key. The housing (2) is bolted in place, e.g. on the frame of a machine in a fixed position. The driving customer-supplied part (lever, handwheel, etc.), which carries actuating pegs (3),

is mounted on the shaft and has two bores to hold the drive studs (4). Thus, if force is applied to the driving part, depending upon the direction in which it is applied one or other of the actuating pegs presses one of the two locking rollers (5) out

of engagement in opposition to the force exerted by the engaging spring (6). In this way, the driven part connected to the centre body can be rotated without difficulty. When this is done the roller which is still engaged operates as in a freewheel mechanism turning in the freewheeling direction. Due to the symmetrical layout of the irreversible lock, the process which has just been described can also take place in the same way in the opposite direction of rotation. If, however, forces coming from the machine attempt to rotate the centre body via the shaft, the centre body is locked to the fixed housing by the locking rollers. Each roller performs this function for one direction of rotation. Thus, the irreversible lock prevents unintended shifts and displacements from taking place. The irreversible locks are not suitable for use where the driven side tends to run ahead of the driving side during operation (e.g. for the operation of brakes during descending movements in lifts and hoists).

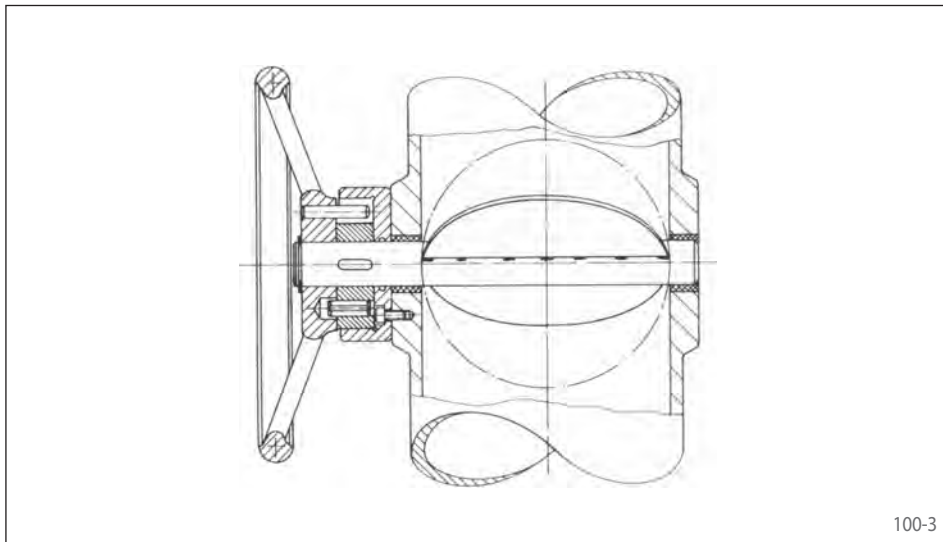
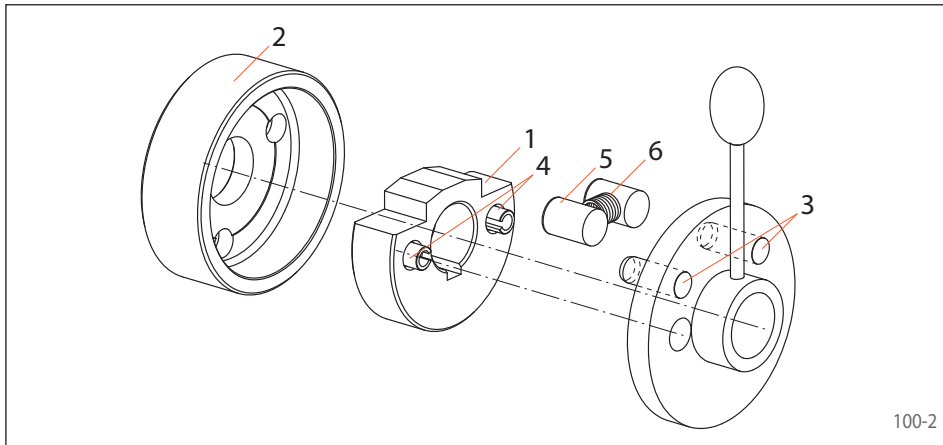

Application example

The valve, which in the example shown is a control or shut-off valve, is adjusted in the opening or closing direction by means of a handwheel.

The Irreversible Lock prevents any uncontrolled shifts in the position of the valve due to the pressure exerted by the medium flowing in the pipe.

The use of Irreversible Locks is not restricted to manually operated valves and they can also be used with motorised adjusters. In this case there is the particular advantage that the torque motor need be designed to supply only the adjusting torque, which is generally low, since all standing and sudden reverse torques are absorbed by the Irreversible Lock.

bidirectional acting backstop for assembly with connecting parts with rollers

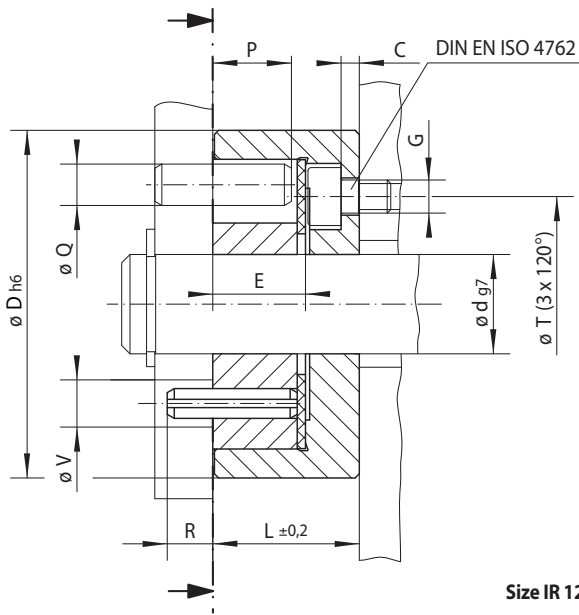

Size IR 12 and IR 16

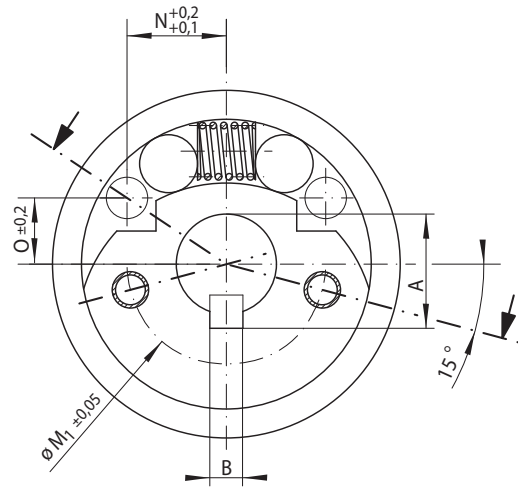

101-1

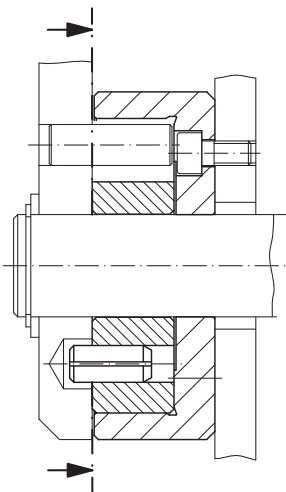

Size IR 25 and IR 35

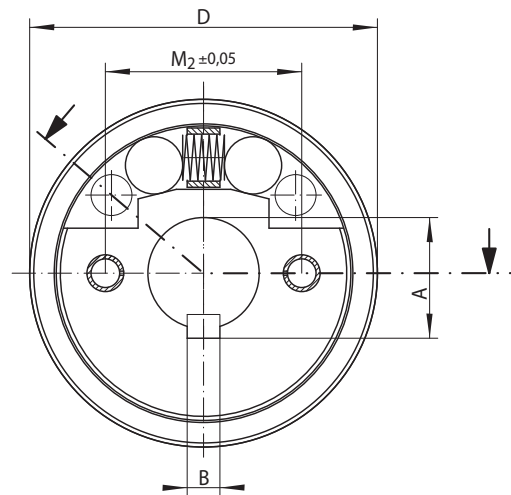

101-2

Backstop	Standard type	Dimensions																		
	For universal use																			

Freewheel Size	Type	Nominal torque M_N Nm	Bore d mm	A* mm	B* mm	C mm	D mm	E mm	G** mm	L mm	M_1 mm	M_2 mm	N mm	O mm	P mm	Q mm	R mm	T** mm	V mm	Z** mm	Weight kg
IR 12	R	8	12	13,8	4	2,2	42	11,2	M4	17,7	24		12,0	8,0	9,5	5	5,5	26	5,7	3	0,15
IR 16	R	15	16	18,3	5	3,0	48	12,2	M5	20,4	28		13,5	9,5	10,5	5	9,5	28	9,8	3	0,22
IR 25	R	48	25	28,5	8	3,2	85	20,0	M6	30,0		48	22,5	19,1	19,5	10	5,5	55	12,2	3	1,10
IR 35	R	100	35	38,5	10	4,5	120	32,0	M8	45,0		70	27,0	32,2	31,5	12	8,5	80	14,2	3	3,30

The maximum transmissible torque is 2 times the specified nominal torque.

* Keyway according to DIN 6885, page 1 • Tolerance of keyway width JS10.

** Z = Number of tapped holes G on pitch circle T.

Example for ordering

Irreversible Lock IR 16 R, standard type with bore 16 mm:

- IR 16 R, d = 16 mm

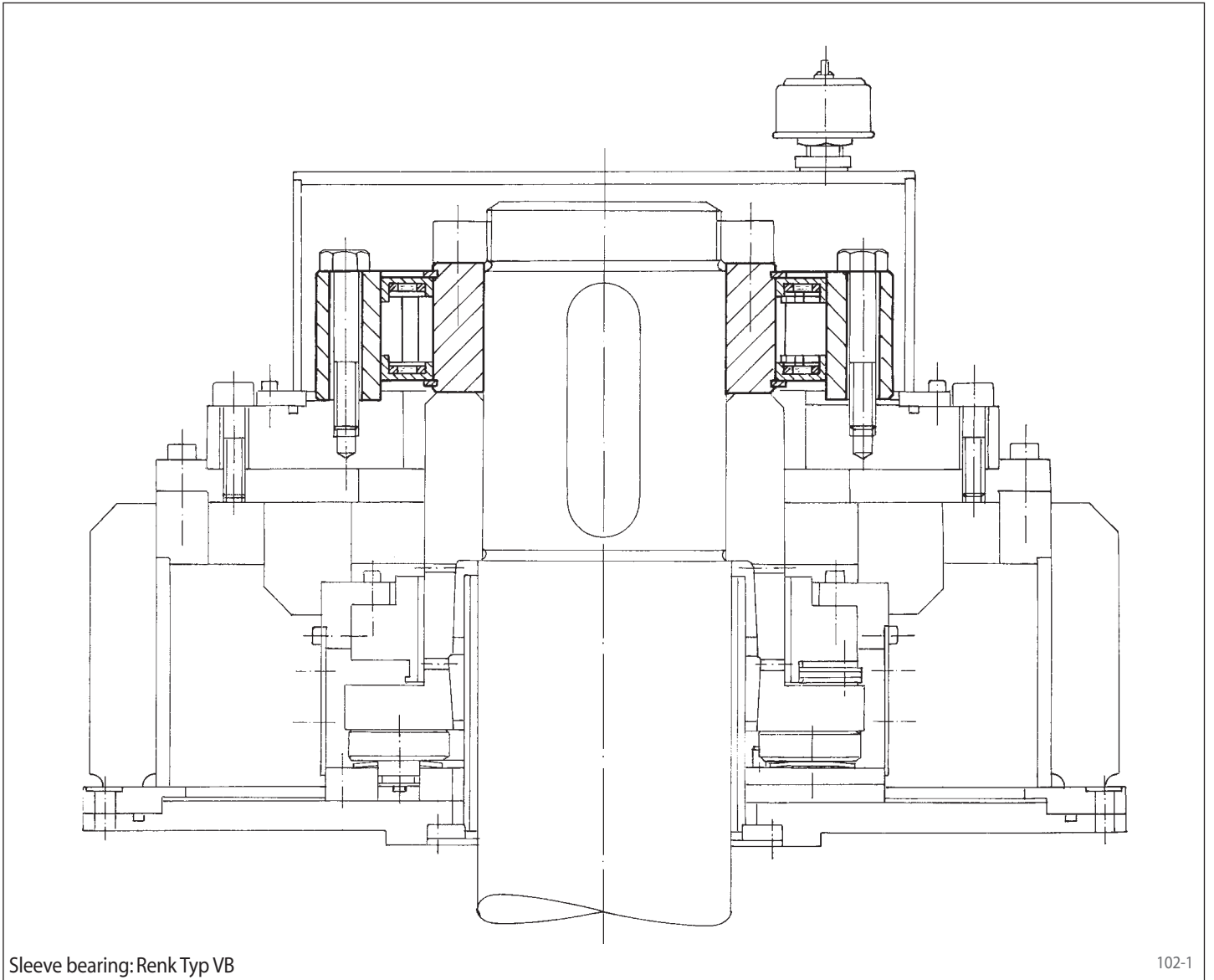

Sleeve bearing: Renk Typ VB

102-1

Backstops FXM ... LX in the drive of large pumps for power stations: In order to guarantee the required operating safety, in accordance with the redundancy principle several parallel working pumps are arranged in one circuit. This also offers the possibility of adapting the feed rate to the respective requirements with the best possible use of the pump capacity.

In pumps that are shut down, the backstops have the task of preventing reverse running under the back pressure of the conveyed medium and thus of preventing the pumps to act

as turbines, while the other pumps of the pump group continue to operate. The reverse speeds and centrifugal forces that occur in such a case would destroy both the pump and the drive motor, incurring down time and considerable repair expense.

The backstop is located immediately above the sleeve bearing of the pump or, as shown in figure 102-1, above the sleeve bearing of the electric motor. Because of the function-related required sleeve bearing play and the unavoidable tolerances of neighbouring parts, the back-

stop needs a considerable misalignment capability. The backstop used with the sprag lift-off X at rotating inner ring permits T.I.R. of up to 0,8 mm.

In normal operation (freewheeling operation), because of the sprag lift-off the backstop works entirely without contact. Therefore, there is no wear on the sprags, and the service life is virtually unlimited. The existing oil mist protects the backstop from corrosion.



Freewheel technology details

103-1

Backstop FXM 2.410 - 100 LX for the primary cooling water pump in a nuclear power station. Maximum torque 500 000 Nm. Speed 1 485 min⁻¹. In service since 1996. Manufactured and tested with extensive documentation from RINGSPANN GmbH, Bad Homburg.



103-2

Iron ore conveyor plant in South Africa driven by three gear reducers with RINGSPANN backstops FXRV 170-63 MX.

Special overrunning clutch for vertical installation, combined with a flexible pin-type coupling. The design is used in the dual drive of air pre-heaters in coal power plants.

The overrunning clutch is essential for both drives so that the respective stationary drive is not backdriven by the output side.

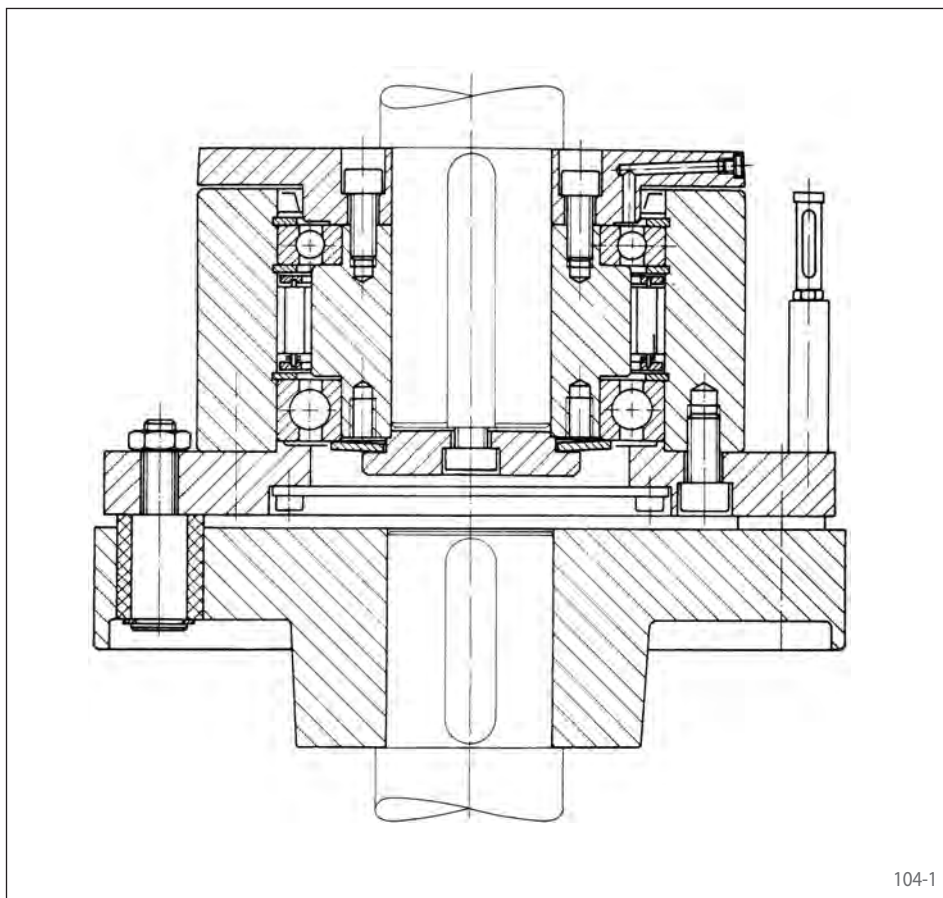

Overrunning clutch with sprag lift-off Z in special maintenance-free design. Lubrication of the sprags in the overrunning clutch is not required because of the high freewheeling speed of the outer ring. The sprags are lifted off of the stationary inner ring under the effect of the centrifugal force and thus operate without wear.

This overrunning clutch also uses life-time lubricated ball bearings and labyrinth seals; therefore, it is maintenance-free.

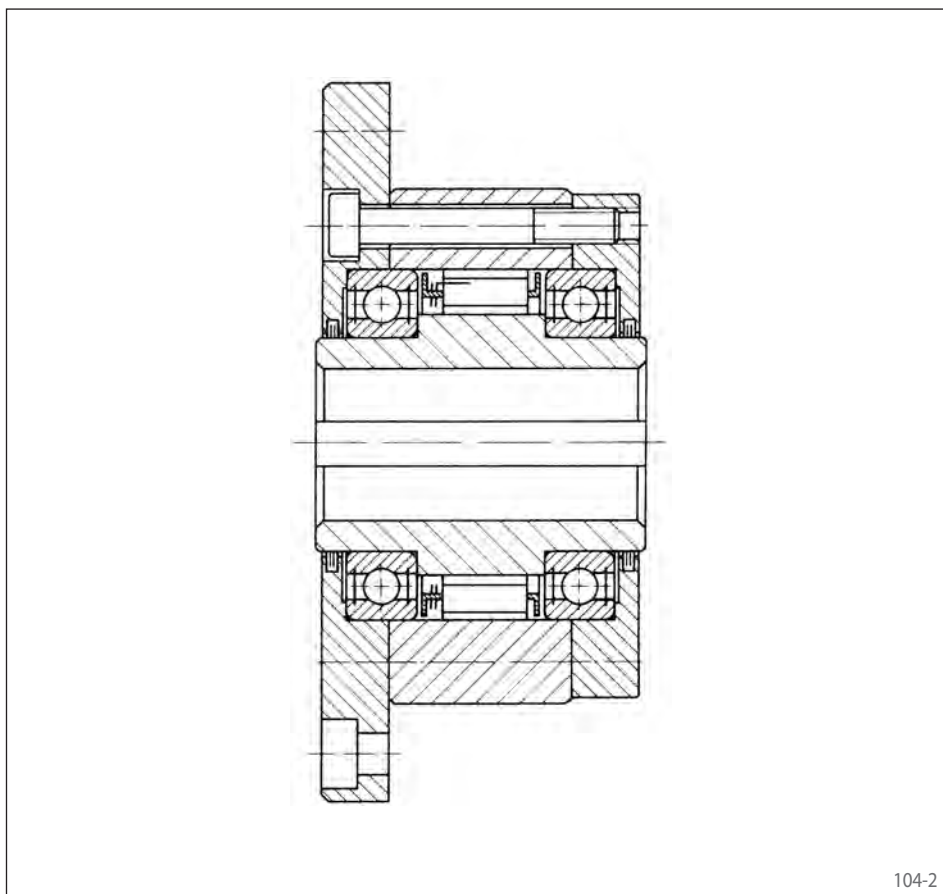

Overrunning clutch FXM 2.240 - 96 LX in custom-made design in the auxiliary drive of a mill. In this special bearing arrangement, the ball bearings of the overrunning clutch only rotate when the mill is driven slowly via the auxiliary drive and the locked overrunning clutch. The inner ring with the mounted freewheel cage runs at high speed, but rotates without contact because of the sprag lift-off X. Hence overheating of the bearings as well as wear on the sprags is avoided.

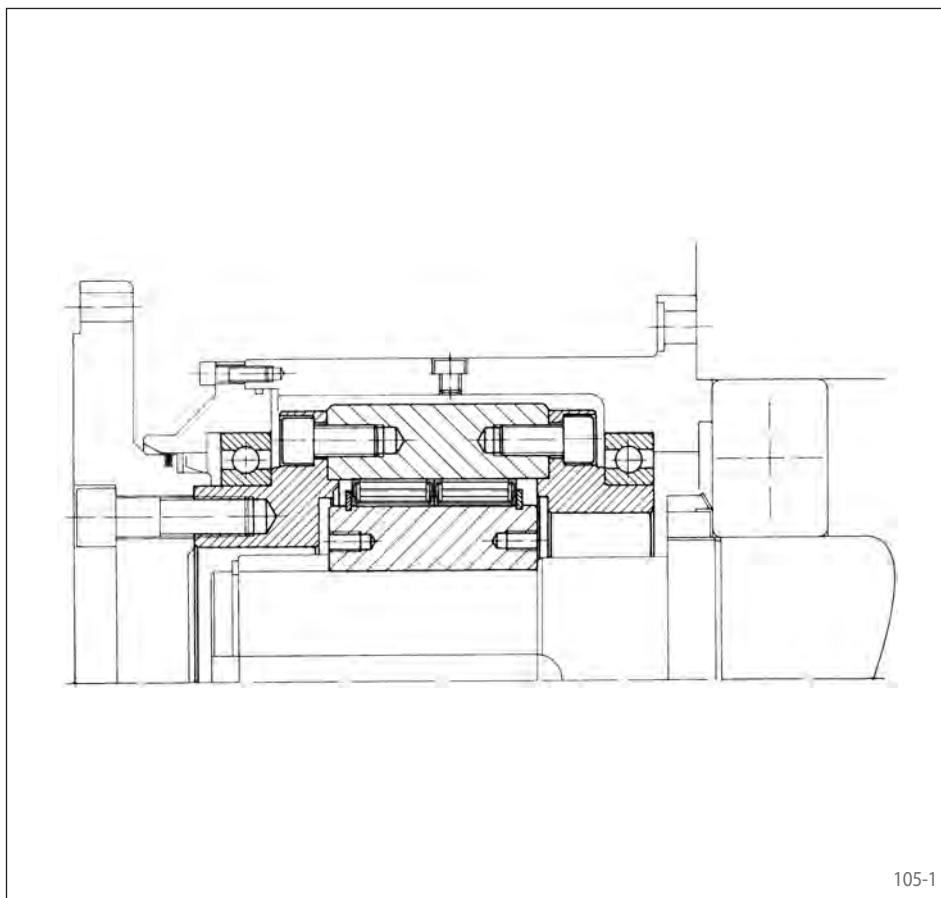

105-1

Integrated Freewheel FON 82 SFR in a special design as a load-operated brake in a non self-locking worm gear. A load is raised or lowered via the worm wheel. The load creates an axial force and this asserts back torque on the worm shaft. A freewheel is located on the worm shaft, the outer ring of the freewheel is connected via friction lining to the gearbox housing.

When the load is lifted, the inner ring freewheels and the freewheel runs in freewheeling operation. When the machine is brought to a standstill, the sprags of the freewheel lock and the back torque of the load is passed into the gearbox housing via the friction lining. If the motor lowers the load, the freewheel is also locked and the motor overcomes the friction torque of the brake.

In this case, the bearing support for the outer ring is secured by means of a special freewheel cage. Beside sprags, this design also includes cylindrical rollers. These rollers provide the centering of the outer ring to the inner ring.

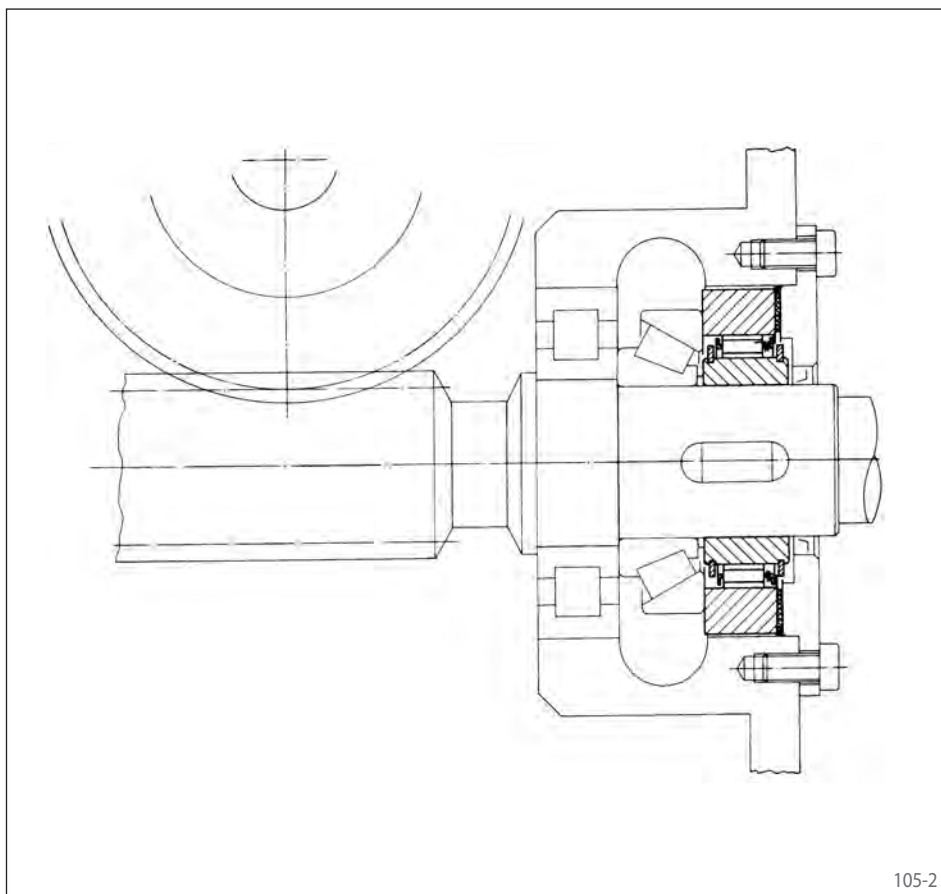

105-2

Bearing support

In the case of freewheels without bearing support, the design must ensure that the inner and outer ring are located concentric to one another with as little as possible play. The sprags do not have a centering effect of the outer ring to the inner ring. If the radial runout exceeds the prescribed limits, the transmissible torques will be reduced which could result in failures.

In the case of freewheels with built-in ball bearings, the customer must check these with

regard to the application related loads in accordance with the calculations from the bearing manufacturer. We will gladly supply you with documents regarding the built-in bearing types and bearing distances.

The series FDN and FD in type CFR have a bearing support to absorb radial forces. A second bearing support must be provided to absorb axial and tilting forces.

Axial forces between the inner and outer rings must not be directed via the sprags or the rollers, as this could interfere with the torque transmission. Therefore, the bearing support between the inner and outer ring must be free from axial play. The best design solution are axially pre-loaded roller bearings.

Central application of force

The forces applied to the freewheel – push rod force, drive belt etc. – should act between the bearings of the freewheel. If the effective line of the lateral force acts outside of the bearing, a

rigid bearing or a pre-loaded bearing must be provided. Otherwise, the service life of the freewheel could be reduced. In the case of indexing freewheels, a central application of force is

required in order to achieve utmost indexing accuracy and highest service life.

Fastening screws for connecting parts

In many freewheels in this catalogue, the customer's connecting parts are bolted to the outer ring of the freewheel. This screw connection is not comparable to a standard screw connection, e.g. like that of a VDI 2230. The torque in the freewheel is only pulsating, i.e. the circumferential force on the screw works in just one direction. The connection between the outer

ring and the connected part is not purely by friction, because the elastic expansion of the outer ring during torque transmission causes movement between the connected parts, until the screws locate circumferentially. Therefore, the screw connections in freewheels must be calculated for shearing. It has proven that for these fastening screws, the material quality 8.8

is sufficient. Because of the higher brittleness, screws of quality 12.9 should not be used. Tightening torques for the freewheel fastening screws should be selected as per the values listed in VDI 2230, in each case taking into account the existing friction values.

Sprag track

The inner sprag track of freewheels without an inner ring (FD series) and the inner and outer sprag track of cage freewheels manufactured by the customer. It must be hardened and machined (grinding or hard-turned). The sprag track must then have the following characteristics:

- Conicity: $\leq 3 \mu\text{m}$ per 10 mm track width
- Average peak-to-valley height Rz as per DIN 4768, page 1: $1,6 \mu\text{m} \leq Rz \leq 6,3 \mu\text{m}$
- Hardness: $62 \pm 2 \text{ HRC}$

With case hardening:

Case hardening depth Eht as per DIN 50190, page 1: 1,5 ... 2 mm, hardness limit HG = 550 HV1, core strength $\geq 1\ 100 \text{ N/mm}^2$

If other hardness processes are to be applied or if you need to deviate from the specified directives, we will gladly offer assistance in working out a solution.

To facilitate mounting when sliding on the freewheel, a lead-in chamfer of, for example, $2 \times 30^\circ$, should be provided on the sprag track.

Transmissible torque

The calculation of the transmissible torque of a freewheel assumes that you know the geometrical associations between the clamping elements and the freewheel rings.

In the case of a sprag freewheel with cylindrical inner and outer ring races, the formula for the inner clamping angle (refer to figure 107-1) is:

$$\tan \varepsilon_i = \frac{Ra}{Ra - Ri} \sqrt{\frac{c^2 - (Ri + ri - Ra + ra)^2}{(Ri + ri)(Ra - ra)}}$$

When calculating the transmissible torque you must also take into consideration the elastic deformations of the freewheel rings. These deformations are created by the large radial forces which the sprags exert on the rings during the locking process. For this purpose, differential equations must be solved that describe the in-

terplay between stresses and deformations in the rings. The Hertzian surface pressure distribution on the contact points between the sprags and the tracks is represented by Fourier's series and inserted as boundary conditions in differential equations. In an iterative process, with continuously increasing forces, geometrical values, deformations and stresses are calculated and compared with the permissible limit values. The following limits must be observed:

- Hertzian pressure on the contact points
- Limit of clamping angle
- Tangential stresses in the rings
- Limit of sprag positional angle

In this calculation the influence of eccentric tracks is also taken into consideration. In addition, the calculation provides the torsion spring

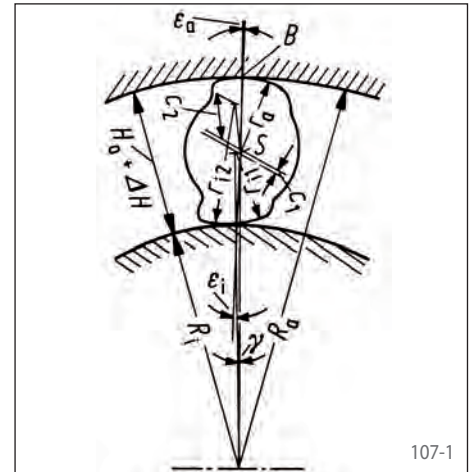

Freewheel technology details

characteristic curve of the freewheel (refer to figure 107-3), which is particularly required for dynamic calculations of an entire installation.

Torsion spring characteristic curve

For many applications, in addition to the torque transmission, the elastic behaviour of the freewheel in a locked state (driving operation) plays a decisive role. As figure 107-2 shows, the outer ring and the inner ring twist (wind-up) against each other during torque transmission. The higher the transmitted torque M the more they twist. The numerical relation between the torque M and the elastic torsional angle is represented in the torsion spring characteristic curve of the freewheel. The calculation of the torsion spring characteristic curve is also carried out using the geometrical values and the deformation equations. Figure 107-3 shows how important the torsion spring characteristic curve is, for example, in the application as indexing freewheel. Here, the torsion spring

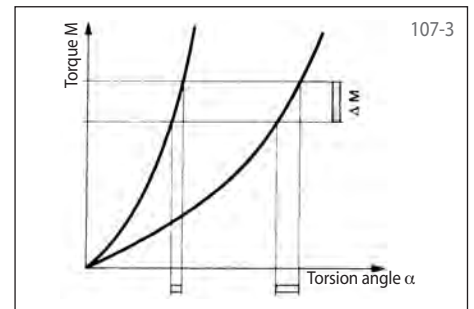
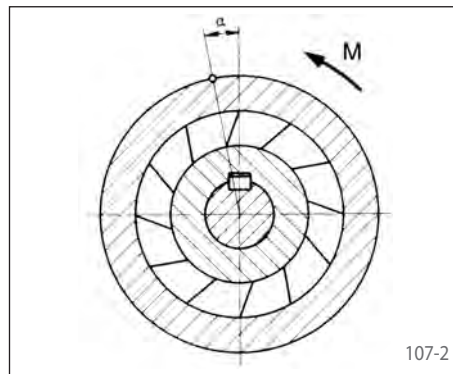

characteristic curves are shown for a "soft" freewheel (flat characteristic curve) and a "stiff" freewheel (steep characteristic curve). If the driving torque M fluctuates, for example, around

the value ΔM, the effect on the torsion angle α of the freewheel with a flat characteristic curve is much greater than that of a freewheel with a steep characteristic curve. In indexed feed drives therefore, you always select freewheels with the steepest possible characteristic curve.

Actuation frequencies and actuation service life of indexing freewheels

In the case of indexing freewheels, the maximum actuation frequency and the service life depending on the actuation frequency are important selection characteristic values.

Maximum actuation frequency:

You cannot give a definite maximum permissible actuation frequency for any given freewheel, as many different influences of the entire machine construction can effect the freewheel. Of particular importance are: Type of machine, size and time course of the actuation torque and the index angle, required indexing accuracy, type of indexing freewheel, type of lubrication, drive of freewheel via inner or outer ring. This partial list shows that you cannot make a general statement regarding the maximum actuation frequency of a given catalogue freewheel. From successful applications with catalogue freewheels maximum actuation

frequencies of up to 800 actuations per minute have been realized.

Actuation service life:

In the case of the actuation service life, it behaves similarly to that of the maximum actuation frequency as the influences on the freewheel are actually the same. It is not possible to calculate an exact number of actuations for any catalogue freewheel. Extensive research of the FVA (German Power Transmission Research Association) have come up with some associations. Of course, the test bench conditions are much idealised and cannot be freely transferred to the practical application conditions of indexing freewheels. In accordance with the research results, the total number of actuations of indexing freewheels is particularly dependent upon the torque and the resulting Hertzian pressure on the clamping points.

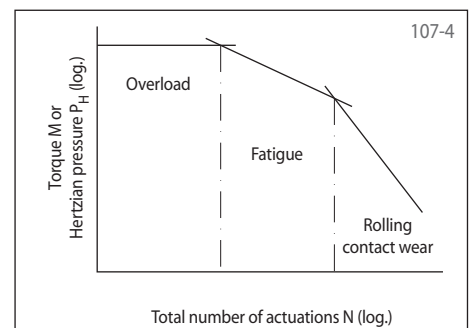

Figure 107-4 shows that we can differentiate between three areas: Overload, fatigue and rolling contact wear. Indexing freewheels must therefore be designed in such a way that they work in the area of rolling contact wear. This way, the total number of actuations can be in excess of 1×10^8 . With an actuation frequency of 100 actuations/minute, this corresponds to a service life of approximately 16 666 hours.

Maximum speeds and service life of backstops and overrunning clutches

The maximum permissible speed of freewheels that are used as backstops or overrunning clutches is primarily dependent upon the

- required service life in freewheeling operation,
- lubrication and heat disipation as well as
- the category of the freewheel.

Dependency of the maximum speed on the required freewheel duration of use

In the case of freewheels with sprags or rollers, wear will occur in the same way as it does with any other sliding machine parts. This wear increases as the relative speed of the sliding parts increases. RINGSPANN has developed different types which can reduce or even reverse these effect. The qualitative course of the service life in freewheeling operation of backstops and overrunning clutches in the various types is shown in figure 108-1. Refer to pages 12 and 13 for more detailed explanations on the types.

The maximum speeds given in the tables here (apart from the types with sprag lift-off X and Z as well as with hydrodynamic sprag lift-off) must always be considered in connection with the minimum required service life in freewheeling operation!

Information regarding the service life in freewheeling operation can be obtained upon request. Simply let us know the operating conditions.

The maximum speeds specified in the tables here apply for an ambient temperature of 20° C. Other maximum speeds will apply for other ambient temperatures or special freewheel designs.

It is generally possible, by means of constructive measures that deviate from the standard design, to achieve even higher speeds. Please contact us if this is the case, preferably using the questionnaire on page 110 or 111.

Dependency of the maximum speed on the lubrication and heat disipation

With regard to the lubrication and heat disipation you must consider two key speed limits:

- Limit of maximum permissible operating temperature as well as the
- limit of lubricant life.

Maximum permissible operating temperature:

The maximum permissible speed of a freewheel in freewheeling operation is, among others, reached if the maximum permissible operating temperature of the freewheel has been reached. Freewheels are lubricated with either oil or grease, in order to minimise the friction between the sliding parts in freewheeling oper-

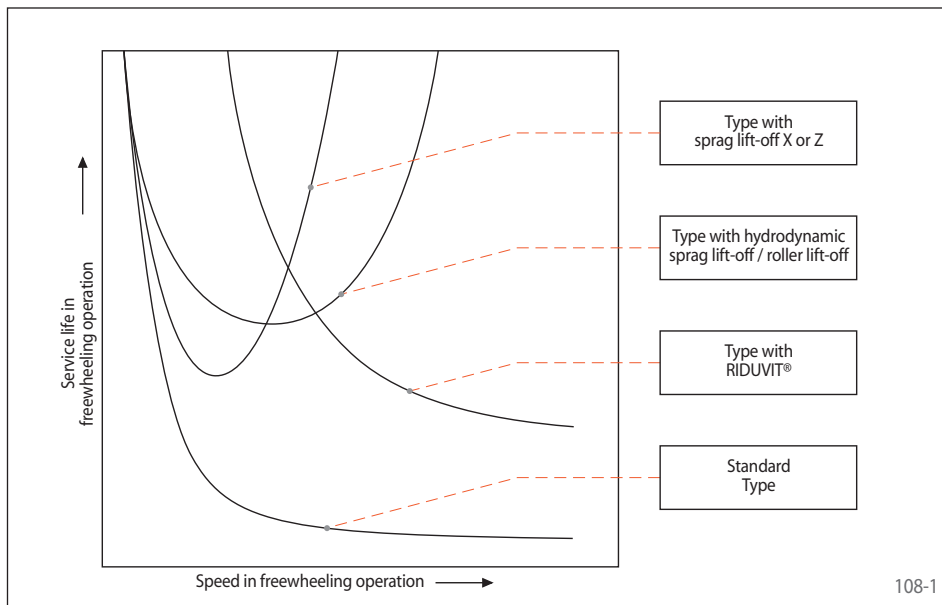

ation. The lubrication also has the function of removing any occurring frictional heat and abrasive wear from the contact points. In principle, it is best to provide oil lubrication as this best facilitates the tasks described above.

In the case of Complete Freewheels and Internal Freewheels of series ZZ ..., which form a unit made up of clamping elements, bearing support, seals and lubrication, there are predominantly four sources of heat that have a restrictive effect on the maximum permissible speed of the freewheel:

- Frictional heat of the seals
- Frictional heat of the lubricant
- Frictional heat of the clamping elements
- Frictional heat of the bearings

The major part of the frictional heat is disipated into the environment. The ambient conditions (ambient temperature, air speed etc.) therefore also have an influence on the operating temperature. Hence, the ambient conditions also have a speed-restricting effect on Complete Freewheels and Internal Freewheels of series ZZ ...

Lubricant life:

The lubricant ages because of the mechanical demands made upon it and after a certain period of use is no longer sufficiently capable of ensuring the function of reducing friction and protecting against wear. The speed of aging depends, among others, on the speed in freewheeling operation. In the event that the lubricant cannot be replaced, the lubricant life must be taken into consideration when establishing the maximum speed. Contact us for information in this regard.

Dependency of the maximum speed on the category of the freewheel

All the components of a freewheel are stressed during rotation because of the centrifugal forces. The maximum permissible component stress must be taken into consideration when establishing the permissible speeds. Furthermore, the service life of the bearings must be considered. The bearing manufacturer's directives must be adhered to. For economic reasons, the standard freewheel is designed for a maximum speed that generally suits most applications. Higher speeds can be achieved by means of special construction measures.

The maximum speeds specified in this catalogue for Basic Freewheels FBO as well as for Integrated Freewheels FON apply for installation conditions as given with Complete Freewheels. Knowing the actual installation conditions higher speeds can be permitted under some circumstances. Please contact us if this is the case, preferably using the questionnaire on page 110 and 111.

Lubrication

For each series the standard lubrication (oil or grease lubrication) is specified on the respective catalogue pages. If a different design is required, please contact us.

The lubricants recommended in the table below for the various ambient temperature ranges have been predominantly chosen for the functioning capabilities of the sprags or the rollers when starting the machine or installation. If, after starting, the freewheel is in operation for a considerable period of time, then an operating temperature will arise in the freewheel that is generally higher than the ambient temperature. For this operating temperature you must check, if the lubrication capabilities of the oil or the basic oil contained in the grease is sufficient for any roller bearings that are built into the freewheel. In critical cases, it has proven useful to use the highly aging-resistant synthetic oil MOBIL SHC 626.

Oil lubrication

The lubrication should be carried out with a non-resinous oil with a kinematic viscosity in accordance with the lubricant table below.

For Complete Freewheels and Housing Freewheels with standard oil lubrication, the oil quantity can be established from the installation and operating instruction manuals.

Integrated Freewheels FXM as well as Internal Freewheels FXN can run with immersion lubrication, circulating lubrication or – in the case of operation above the sprag lift-off speed – without oil lubrication. With these series it is also permissible to use oils and greases with friction-value-reducing additives (molybdenum disulphide). If operating without oil lubrication, the sprags and the outer track must be greased prior to installation with a suitable viscous grease in accordance with the installation and operating instruction manual.

In the case of designs with Basic Freewheels, Integrated Freewheels FON and Internal Freewheels with oil lubrication, ensure that the inner track is immersed in the oil.

If an immersion lubrication is not possible, an oil circulating lubrication must be provided, which will then ensure a constant oil film on the inner track.

Grease lubrication

The freewheels FA, FAV and ZZ ... have a grease lubrication that is designed to last for the service life. It is maintenance-free and generally requires no subsequent lubrication.

In order to increase the service life of freewheels with grease lubrication, after an operating time of about two years the freewheels should be disassembled, cleaned, checked and regreased. Refer to the lubrication table for recommended greases.

Attention

Oils and greases that contain friction-reducing additives like molybdenum disulphide or the like, may only be used with authorisation of RINGSPANN. Exception: Integrated Freewheels FXM as well as Internal Freewheels FXN.

Lubrication table

Manufacturer	Oil			Grease
	For ambient temperatures from 0° C to +50° C Kinematic viscosity at 40° C, ISO-VG 46/68 [mm ² /s]	For ambient temperatures from -15° C to +15° C Kinematic viscosity at 40° C, ISO-VG 32 [mm ² /s]	For ambient temperatures from -40° C to 0° C Kinematic viscosity at 40° C, ISO-VG 10 [mm ² /s]	For ambient temperatures from -15° C to +50° C
Agip	OSO 46/68	OSO 32	OSO 10	
ARAL	VITAM GF 46/68	VITAM GF 32	VITAM GF 10	ARALUB HL2
BP	ENERGOL HLP-HM 46/68	ENERGOL HLP-HM 32	ENERGOL HLP-HM 10	ENERGREASE LS2
CASTROL	VARIO HDX	VARIO HDX	ALPHASYN T 10	
CHEVRON	HYDRAULIC OIL AW 46/68	HYDRAULIC OIL AW 32	RANDO HD 10	
KLÜBER	LAMORA HLP 46/68	LAMORA HLP 32	Klüberoil 4 UH1-15	ISOFLEX LDS 18 Spezial A POLYLUB WH 2 Klübersynth BM 44-42
MOBIL	DTE 25/26 NUTO H 46/68	DTE 24 NUTO H 32	DTE 10 Excel 15 UNIVIS HVI 13	MOBILUX EP 2
SHELL	TELLUS 46/68	TELLUS 32	TELLUST 15	ALVANIA RL2
TOTAL	AZOLLA ZS 46/68	AZOLLA ZS 32	EQUIVIS XLT 15	MULTIS EP 2
other manufacturers	Gearbox or hydraulic oils without solid lubricants ISO-VG 46/68	Gearbox or hydraulic oils without solid lubricants ISO-VG 32; Automatic transmission fluids [ATF]	Gearbox or hydraulic oils without solid lubricants ISO-VG 10; note setting point! Aviation hydraulic oils ISO-VG 10	

Please contact us in the case of temperatures in excess of 50° C and below -40° C.

Questionnaire for selecting RINGSPANN Backstops

Please photocopy or use the PDF-File from our website!

Company:	Date:
Address:	Enquiry Ref.:
.....	Phone:
Name:	Fax:
Department:	E-mail:

1. Where will the Backstop be used?

<p>1.1 Type of machine: _____</p> <p>In the case of conveyor belts: Angle of the steepest segment _____ ° Multiple-drive? <input type="checkbox"/> Yes <input type="checkbox"/> No If yes, number of drives _____</p> <p>1.2 Backstop location: <input type="checkbox"/> on the gearbox <input type="checkbox"/> on the motor <input type="checkbox"/> elsewhere: _____</p>	<p>1.3 Arrangement: <input type="checkbox"/> on the shaft end Diameter: _____ mm Length: _____ mm <input type="checkbox"/> on a through shaft Diameter: _____ mm <input type="checkbox"/> on a pulley <input type="checkbox"/> on a sprocket <input type="checkbox"/> elsewhere: _____</p>	<p>1.4 If possible, please include specification, data sheet, sketch or drawing with connection dimensions.</p> <p>_____</p> <p>_____</p> <p>_____</p> <p>_____</p> <p>_____</p>
---	--	--

2. Operating data

<p>2.1 Speed at the backstop location (backstop shaft) $n_{sp} =$ _____ min^{-1}</p> <p>Would it be possible to arrange the backstop on a high speed shaft? (higher speed = lower torque = smaller backstop) If necessary please give further details on the drawing.</p>	<p>2.2 Nominal power of motor $P_0 =$ _____ kW</p> <p>2.3 Must the backstop also absorb the peak torque that occurs if the drive motor is started in the locking direction of the backstop (incorrectly poled drive motor)? If yes, the backstop must be substantially oversized. <input type="checkbox"/> Yes <input type="checkbox"/> No</p>	<p>2.4 Maximum backdriving torque $M_{max} =$ _____ Nm</p> <p>2.5 Lifting capacity of the conveyor system $P_L =$ _____ kW</p> <p>2.6 Efficiency of the machine between backstop and drive $\eta =$ _____</p> <p>2.7 Number of daily locking processes: _____</p> <p>2.8 Daily operating time: _____ hours</p>
---	--	--

3. Installation conditions

<p>3.1 <input type="checkbox"/> Open, outside <input type="checkbox"/> Open, in a closed room <input type="checkbox"/> In the machine housing <input type="checkbox"/> Lubrication by means of oil bath or oil mist in the machine housing <input type="checkbox"/> Connection to the central lubrication system is possible Name of lubricant: _____ Kinematic viscosity: _____ mm^2/s _____ °C</p>	<p>3.2 Should the backstop be releasable? <input type="checkbox"/> No <input type="checkbox"/> Yes, in an emergency <input type="checkbox"/> Yes, frequently</p> <p>3.3 Ambient temperature on the backstop: from _____ °C to _____ °C</p> <p>3.4 Other (e.g. accessibility, dust susceptibility and other environmental influences that could be of significance): _____ _____ _____</p>	<p>3.5 Are there any elastic elements/components located between the backstop and the installation that is to be backstopped (elastic couplings generate considerable peak torques at the moment of stopping)? <input type="checkbox"/> Yes <input type="checkbox"/> No</p>
---	---	--

4. Estimated requirements

_____ Pieces (one-off) _____ Pieces/month _____ Pieces/year

5. Enclosures

Specifications Data sheet Sketch/drawing



RINGSPANN GmbH

Schaberweg 30-38
 61348 Bad Homburg, Germany

Phone +49 6172 275-0
 Fax +49 6172 275-275

www.ringspann.com
 info@ringspann.com

Questionnaire for selecting RINGSPANN Overrunning Clutches

Please photocopy or use the PDF-File from our website!

Company:	Date:
Address:	Enquiry Ref.:
.....	Phone:
Name:	Fax:
Department:	E-mail:

1. Where will the Overrunning Clutch be used?

<p>1.1 Type of machine, machine group or installation, in which the overrunning clutch will be used:</p> <p>_____</p> <p>_____</p> <p>_____</p> <p>_____</p> <p>_____</p>	<p>1.2 Arrangement of the overrunning clutch (if possible, please include specification, data sheet, sketch or drawing with connection dimensions).</p> <p>_____</p> <p>_____</p> <p>_____</p> <p>_____</p>
---	---

2. Operating data

<p>2.1 In driving operation the drive of the overrunning clutch will be carried out by:</p> <p><input type="checkbox"/> Asynchronous motor</p> <p style="margin-left: 20px;"><input type="checkbox"/> direct start-up</p> <p style="margin-left: 20px;"><input type="checkbox"/> λ-Δ-start-up</p> <p><input type="checkbox"/> Other electric motor</p> <p style="margin-left: 20px;">Type: _____</p> <p><input type="checkbox"/> Combustion engine</p> <p style="margin-left: 20px;">Type: _____</p> <p style="margin-left: 20px;">Number of cylinders: ____</p> <p><input type="checkbox"/> Turbine</p> <p><input type="checkbox"/> Other (please explain in more detail):</p> <p>_____</p> <p>_____</p>	<p>2.3 Maximum torque _____ Nm (Important for drives that develop their maximum torque below their nominal speed.)</p> <p>2.4 Speed</p> <p>1. in driving operation: from _____ min⁻¹ to _____ min⁻¹</p> <p>2. in freewheeling operation: (when overrunning clutch is disengaged)</p> <p style="margin-left: 20px;">Primary part (driver) from _____ min⁻¹ to _____ min⁻¹</p> <p style="margin-left: 20px;">Secondary part (driven machine) from _____ min⁻¹ to _____ min⁻¹</p> <p>2.5 Should the overrunning clutch be combined with a shaft coupling?</p> <p><input type="checkbox"/> with an elastic coupling</p> <p><input type="checkbox"/> with a torsionally stiff coupling</p> <p><input type="checkbox"/> _____</p>	<p>2.6 If, upon start up, larger masses are to be accelerated:</p> <p>Moment of inertia: J = _____ kgm²</p> <p>Speed of mass: n = _____ min⁻¹</p> <p>2.7 Torque fluctuations/torsional vibrations during driving operation generate the following torque limits</p> <p><input type="checkbox"/> Minimum torque M_{min} = _____ Nm</p> <p><input type="checkbox"/> Maximum torque M_{max} = _____ Nm</p> <p><input type="checkbox"/> Minimum or Maximum torque is not known</p> <p>2.8 Daily operating time: _____ hours (h) thereof _____ (h) driving operation thereof _____ (h) freewheeling operation</p>
<p>2.2 To be transmitted in driving operation:</p> <p>Power: _____ kW or</p> <p>Torque: _____ Nm</p>		

3. Installation conditions

<p>3.1 <input type="checkbox"/> Open, outside</p> <p><input type="checkbox"/> Open, in a closed room</p> <p><input type="checkbox"/> in the machine housing</p> <p style="margin-left: 20px;"><input type="checkbox"/> Lubrication by means of oil bath or oil mist in the machine housing</p> <p style="margin-left: 20px;"><input type="checkbox"/> Connection to the central lubrication system is possible</p> <p>Name of lubricant: _____</p> <p>Kinematic viscosity _____ mm²/s _____ °C</p>	<p>3.2 Ambient temperature on the freewheel: from _____ °C to _____ °C</p> <p>3.3 Other (e.g. accessibility, dust susceptibility and other environmental influences that could be of significance):</p> <p>_____</p> <p>_____</p> <p>_____</p>
---	--

4. Estimated requirements

_____ Pieces (one-off)

_____ Pieces/month

_____ Pieces/year

5. Enclosures

- Specifications
- Data sheet
- Sketch/drawing



RINGSPANN GmbH

Schaberweg 30-38
61348 Bad Homburg, Germany

Phone +49 6172 275-0
Fax +49 6172 275-275

www.ringspann.com
info@ringspann.com

Questionnaire for selecting RINGSPANN Indexing Freewheels

Please photocopy or use the PDF-File from our website!

Company:	Date:
Address:	Enquiry Ref.:
.....	Phone:
Name:	Fax:
Department:	E-mail:

1. Where will the Indexing Freewheel be used?

1.1 Type of machine, machine group or installation, in which the indexing freewheel will be used: 		1.2 Arrangement of the indexing freewheel (if possible, please include specification, data sheet, sketch or drawing with connection dimensions).
---	--	---

2. Operating data

2.1 Index angle of the indexing freewheel: from° to°	2.4 The back and forth movement is generated by <input type="checkbox"/> bell crank <input type="checkbox"/> hydraulic cylinder <input type="checkbox"/> pneumatic cylinder <input type="checkbox"/> cam disk or plate <input type="checkbox"/> other (please explain in more detail):	2.5 Proposed shaft dimensions: Diameter mm Length mm
2.2 Number of actuations (indexes) per minute: from/min to/min		2.6 Normal torque: M = Nm Maximum torque: M _{max} = Nm (including peaks)
2.3 The back and forth movement is made by <input type="checkbox"/> freewheel outer ring <input type="checkbox"/> freewheel inner ring <input type="checkbox"/>		2.7 Daily operating time: hours

3. Installation conditions

3.1 <input type="checkbox"/> Open, outside <input type="checkbox"/> Open, in a closed room <input type="checkbox"/> in the machine housing <input type="checkbox"/> Lubrication by means of oil bath or oil mist in the machine housing <input type="checkbox"/> Connection to the central lubrication system is possible Name of lubricant: Kinematic viscosity: mm ² /s °C	3.2 Ambient temperature on freewheel: from°C to°C	3.3 Other (e.g. accessibility, dust susceptibility and other environmental influences that could be of significance):
---	--	--

4. Estimated requirement

..... Pieces (one-off) Pieces/month Pieces/year

5. Enclosures

Specifications Data sheet Sketch/drawing



RINGSPANN GmbH

Schaberweg 30-38
61348 Bad Homburg, Germany

Phone +49 6172 275-0
Fax +49 6172 275-275

www.ringspann.com
info@ringspann.com

Questionnaire for selecting RINGSPANN Housing Freewheels FH

Please photocopy or use the PDF-File from our website!

Company:	Date:
Address:	Enquiry Ref.:
.....	Phone:
Name:	Fax:
Department:	E-mail:

1. Where will the Housing Freewheels be used?

1.1 Type of installation:

1.2 Type of working machine:



2. Operating data

2.1 In driving operation the drive will be carried out by

Housing Freewheel A

- Asynchronous motor
 Direct start up λ - Δ -start up
 Other electric motor
 Type:
- Combustion engine
 Type: No. of cylinders:
- Turbine
 Other (please explain in more detail):

Housing Freewheel B

- Asynchronous motor
 Direct start up λ - Δ -start up
 Other electric motor
 Type:
- Combustion engine
 Type: No. of cylinders:
- Turbine
 Other (please explain in more detail):

2.2 Speeds in driving operation
 Speeds in freewheeling operation

from min⁻¹ to min⁻¹
 from min⁻¹ to min⁻¹

from min⁻¹ to min⁻¹
 from min⁻¹ to min⁻¹

2.3 Direction of rotation in driving operation when viewed in direction X

- Counterclockwise
 Clockwise

- Counterclockwise
 Clockwise

2.4 To be transmitted in driving operation

Power: kW
 Torque: Nm

Power: kW
 Torque: Nm

2.5 Maximum torque determined by rotational vibration calculation

..... Nm

..... Nm

2.6 Should the Housing Freewheel be combined with shaft coupling?

- With elastic coupling
 Type:
- With torsionally stiff coupling
 Type:

- With elastic coupling
 Type:
- With torsionally stiff coupling
 Type:

2.7 Selected Housing Freewheel

Size

Size

2.8 Daily operating time

..... hours (h)
 thereof (h) driving operation
 thereof (h) freewheeling operation

..... (h) driving operation
 thereof (h) freewheeling operation

3. Installation conditions

3.1 Ambient temperature on the freewheel:
 from °C to °C

3.2 Other (e.g. accessibility, dust susceptibility and other environmental influences that could be of significance):

4. Estimated requirements

..... Pieces (one-off) Pieces/month Pieces/year

5. Enclosures

- Specifications Data sheet Sketch/drawing



RINGSPANN GmbH

Schaberweg 30-38
 61348 Bad Homburg, Germany

Phone +49 6172 275-0
 Fax +49 6172 275-275

www.ringspann.com
 info@ringspann.com

Questionnaire for selecting RINGSPANN Housing Freewheels FCBM

Please photocopy or use the PDF-File from our website!

Company: Address: Name: Department:	Date: Enquiry Ref.: Phone: Fax: E-mail:
1. Main Drive Number of Main Motors <input type="checkbox"/> 1 <input type="checkbox"/> 2 Power of Main Motors (1) kW (2) kW Speed of each motor (1) min ⁻¹ (2) min ⁻¹ Main Reducer Ratio	
2. Auxiliary Drive (Emergency Drive) Number of Auxiliary Drives <input type="checkbox"/> 1 <input type="checkbox"/> 2 Power Auxiliary Drives (1) kW (2) kW Speed of each Motor (1) min ⁻¹ (2) min ⁻¹ Auxiliary Reducer Ratio Type of Emergency Drive Unit <input type="checkbox"/> E-Motor <input type="checkbox"/> Engine <input type="checkbox"/>	
3. Girth Gear & Pinion Ratio	
4. Voltage to be supplied to the electromagnetically released multi-disc brake <input type="checkbox"/> 230 VAC +/- 10% (207-253 V) at 50 Hz <input type="checkbox"/> 400 VAC +/- 10% (360-440 V) at 50 Hz <input type="checkbox"/> 115 VAC +/- 10% (103-126 V) at 60 Hz <input type="checkbox"/> Special voltage VAC / Hz or VDC	
5. Direction of Rotation Direction of rotation in driving operation when viewed in direction X (1) FCBM Direction of freewheeling rotation: (2) FCBM Direction of freewheeling rotation: <input type="checkbox"/> Counterclockwise <input type="checkbox"/> Counterclockwise <input type="checkbox"/> Clockwise <input type="checkbox"/> Clockwise	
6. Position of electromagnetically released multi-disc brake when viewed in direction X (1) FCBM Mounting side of electromagnetically released multi-disc brake <input type="checkbox"/> right <input type="checkbox"/> left (2) FCBM Mounting side of electromagnetically released multi-disc brake <input type="checkbox"/> right <input type="checkbox"/> left	
7. Estimated requirements Pieces (one-off) Pieces/month Pieces/year	
8. Enclosures <input type="checkbox"/> Specifications <input type="checkbox"/> Data sheet <input type="checkbox"/> Sketch/drawing	



RINGSPANN GmbH

Schaberweg 30-38
61348 Bad Homburg, Germany

Phone +49 6172 275-0
Fax +49 6172 275-275

www.ringspann.com
info@ringspann.com

Germany

RINGSPANN GmbH
Schaberweg 30-38
61348 Bad Homburg
Germany
+49 61 72 275 0
info@ringspann.de
www.ringspann.com

RINGSPANN RCS GmbH
Hans-Mess-Straße 7
61440 Oberursel
Germany
+49 61 72 67 68 50
info@ringspann-rcs.de
www.ringspann-rcs.com

Sweden, Finland,
Denmark, Norway,
Baltic states

RINGSPANN Nordic AB
Industrigatan 7
61933 Trosa
Sweden
+46 156 190 98
info@ringspann.se
www.ringspann.se

France

SIAM - RINGSPANN S.A.
23 rue Saint-Simon
69009 Lyon
France
+33 4 78 83 59 01
info@siam-ringspann.fr
www.ringspann.fr

Netherlands, Belgium,
Luxembourg

RINGSPANN Benelux B.V.
Nieuwenkampsmaten 6-15
7472 De Goor
Netherlands
+31 547 26 13 55
info@ringspann.nl
www.ringspann.nl

Switzerland

RINGSPANN AG
Sumpfstrasse 7
6300 Zug
Switzerland
+41 41 748 09 00
info@ringspann.ch
www.ringspann.ch

Great Britain, Ireland

RINGSPANN (U.K.) LTD.
3, Napier Road
Bedford MK41 0QS
Great Britain
+44 1234 3425 11
info@ringspann.co.uk
www.ringspann.co.uk

Austria, Hungary,
Slovenia

Edmayr Antriebstechnik GmbH
Thalham 20
4880 St. Georgen
Austria
+43 7667 68 40
office@edmayr.at
www.ringspann.com

Spain, Portugal

RINGSPANN IBERICA S.A.
C/Uzbina, 24-Nave E1
01015 Vitoria
Spain
+34 945 22 77-50
info@ringspann.es
www.ringspann.es

Italy

RINGSPANN Italia S.r.l.
Via A. De Gasperi, 31
20020 Lainate (MI)
Italy
+39 02 93 57 12 97
info@ringspann.it
www.ringspann.it

Poland

RADIUS-RADPOL sp.j.
Wiecheć, Labacki
ul. Kolejowa 16b
60 185 Skórzewo
Poland
+48 61 814 39 28
info@radius-radpol.com.pl
www.radiusradpol.pl

Czech Republic,
Slovakia

Ing. Petr Schejbal
Mezivrší 1444/27
147 00 Praha
Czech Republic
+420 222 96 90 22
Petr.Schejbal@ringspann.cz
www.ringspann.com

Asia

Australia, New Zealand

Kempower Pty. Ltd.
6 Phoenix Court, Braeside
3195 Victoria
Australia
+61 3 95 87 90 33
dirk@imtec-kempower.com.au
www.imtec-kempower.com.au

China, Taiwan

**RINGSPANN Power Transmission
(Tianjin) Co., Ltd.**
No. 21 Gaoyan Rd.
Binhai Science and Technology Park
Binhai Hi-Tech Industrial
Development Area
Tianjin, 300458
P.R. China
+86 22 59 80 31 60
info.cn@ringspann.cn
www.ringspann.cn

India, Bangladesh, Nepal

**RINGSPANN Power Transmission
India Pvt. Ltd.**
GAT No: 679/2/1
Village Kuruli, Taluka Khed
Chakan-Alandi Road
Pune - 410501
India
+91 21 35 67 75 00
info@ringspann-india.com
www.ringspann-india.com

Singapore, ASEAN

RINGSPANN Office
Arthur Low
1 Scotts Road
#21-10 Shaw Centre
Singapore 228208
+65 96 33 66 92
Arthur.Low@ringspann.com
www.ringspann.com

America

Brazil

Antares Acoplamentos Ltda.
Rua Evaristo de Antoni, 1222
Caxias do Sul, RS
CEP 95041-000
Brazil
+55 54 32 18 68 00
cristiano@antaresacoplamentos.com.br
www.antaresacoplamentos.com.br

Africa and Middle East

Egypt

Shofree Trading Co.
218 - emtedad Ramsis (2)
2775 Nasr City Cairo
Egypt
+20 2 20 81 20 57
info@shofree.com
www.ringspann.com

Algeria, Morocco, Tunisia

SIAM - RINGSPANN S.A.
23 rue Saint-Simon
69009 Lyon
France
+33 4 78 83 59 01
info@siam-ringspann.fr
www.ringspann.fr

Iran

Rastan Felez Taha Eng Trading Co (RFT)
Unit No. 8
461, North Kargar Avenue
Tehran postal code 1413683164
Iran
+98 21 88 00 94 35
info@rftrft.com
www.ringspann.com

USA, Canada, Mexico,
Chile, Peru

RINGSPANN Corporation
10550 Anderson Place
Franklin Park, IL 60131
U.S.A
+1 847 678 35 81
info@ringspanncorp.com
www.ringspanncorp.com

Israel

G.G. Yarom Rolling and Conveying Ltd.
6, Hamaktesh Str.
58810 Holon
Israel
+972 3 557 01 15
noam_a@gg.co.il
www.ringspann.com

South Africa, Sub-Saharan

**RINGSPANN Transmission
Components (Pty) Ltd.**
96 Plane Road Spartan
Kempton Park
P.O. Box 8111 Edenglen 1613
South Africa
+27 11 394 18 30
info@ringspann.co.za
www.ringspann.co.za